



This manual is for reference and historical purposes, all rights reserved.

This page is copyright© by M. Butkus, NJ.

This page may not be sold or distributed without the expressed permission of the producer

I have no connection with any camera company

On-line camera manual library

This is the full text and images from the manual. This may take 3 full minutes for the PDF file to download.

If you find this manual useful, how about a donation of \$3 to: M. Butkus, 29 Lake Ave., High Bridge, NJ 08829-1701 and send your e-mail address so I can thank you. Most other places would charge you \$7.50 for a electronic copy or \$18.00 for a hard to read Xerox copy.

This will allow me to continue to buy new manuals and pay their shipping costs.

It'll make you feel better, won't it?

**If you use Pay Pal or wish to use your credit card,
click on the secure site on my main page.**

the automatic
omega

120

camera

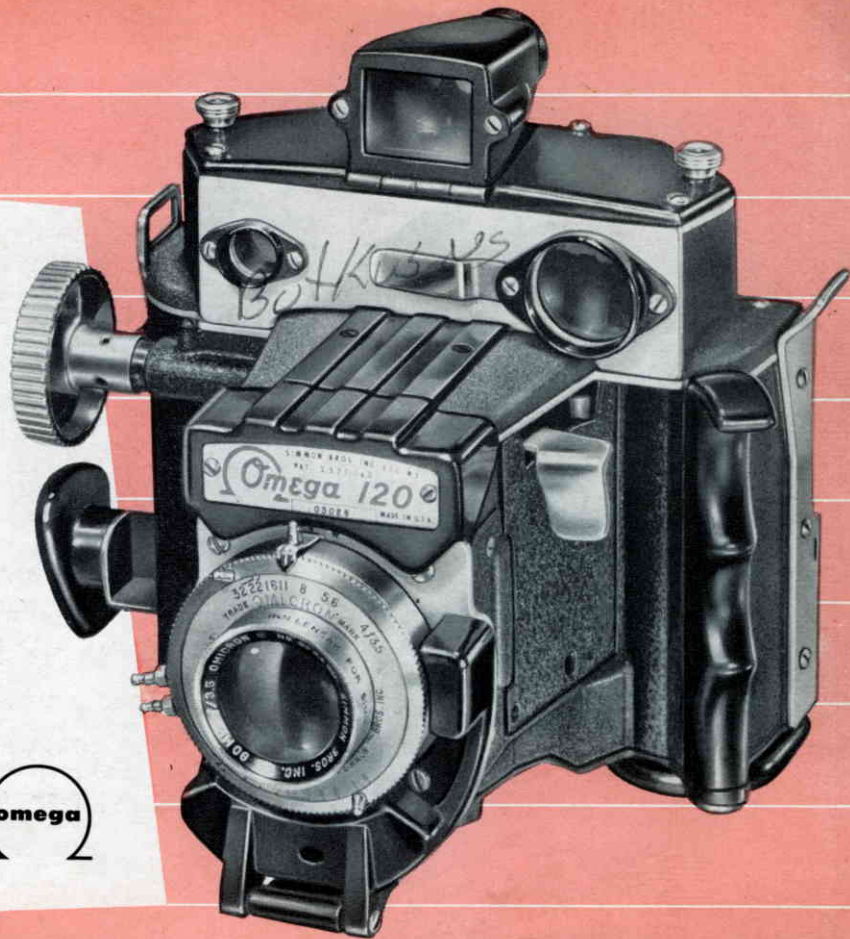

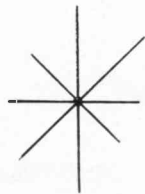

the automatic **omega**

120

camera

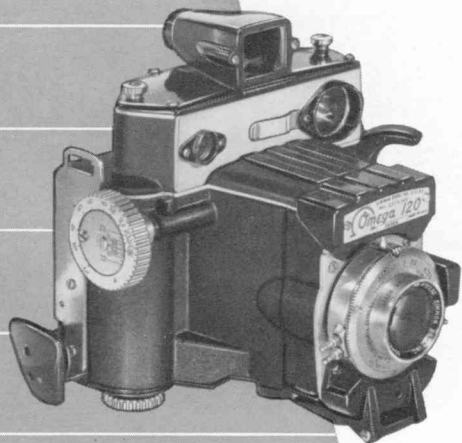

is a very simply and easily operated, rapid sequence, high precision camera of light weight with entirely functional design which produces unusually sharp and excellent pictures with consistency.

The Omega 120 camera takes nine 2¼" x 2¾" pictures (4:5 proportion) on No. 120 film. This negative size matches the proportions of the enlarging paper. It was designed for easy composition and requires less enlarging than the square format so that it contributes to superior picture quality.

The OMEGA 120 CAMERA was designed for outstanding performance and to produce consistently the excellent pictures which modern optics are capable of producing but which they can not produce when built into less precise instruments. It has one of the finest photographic lenses ever produced, designed especially for SIMMON BROTHERS, INC. and built into a high precision camera body. The OMEGA 120 will consistently give you optimum definition because its brilliant over-sized range finder is easier and faster to focus and your negative is kept absolutely flat by means of the exclusive retractable pressure plate. No fear of blurring pictures due to jarring the camera because it is so designed as to give you a good, steady grip. The OMEGA 120 incorporates a shutter speed of from one second to 1/400 of a second. It produces 4 x 5 picture quality on 120 film.

**outstanding
performance**

The OMEGA 120 CAMERA is fully automatic. It has automatic double exposure prevention and automatic parallax compensation. The Autofilm Transport automatically cocks the shutter and advances the film for next exposure in split seconds. Simultaneously, a red dot appears in a small window indicating the camera is set for your next picture. The versatile Autofilm Transport also automatically locks the OMEGA 120 and closes the film window after loading.

**fully
automatic**

**exclusive film
pressure plate**

As the shutter is released, an automatic film pressure plate is actuated to keep the film precisely flat in the focal plane during exposure which means consistent maximum sharpness! The plate, one of the most important innovations in the OMEGA 120 CAMERA, is ground perfectly flat, during manufacture, on a surface grinder for micro-accuracy. It is retractable and automatically releases the film after each exposure. OMEGA's film pressure plate is a major contribution toward the superb picture quality always yours with the OMEGA 120.

**brilliant
over-sized
range finder**

The large, over-sized range finder with its brilliant, magnified image and large field finds the optimum point of definition without a moment's hesitation even in poor lighting, an OMEGA characteristic indispensable for effective flash photography. The unusually large field is enlarged $1\frac{1}{2}$ times for extremely critical focusing. The view finder shows the image at $\frac{2}{3}$ of natural size which is also unusually large.

**rapid
sequence**

The OMEGA 120 CAMERA is built for quick handling and instant action, rapid sequence photography. It is fully automatic, has an easy-to-focus range finder, a rapid Autofilm Transport, a convenient shape and its controls are so located as to make possible *Two-Hand Operation*.

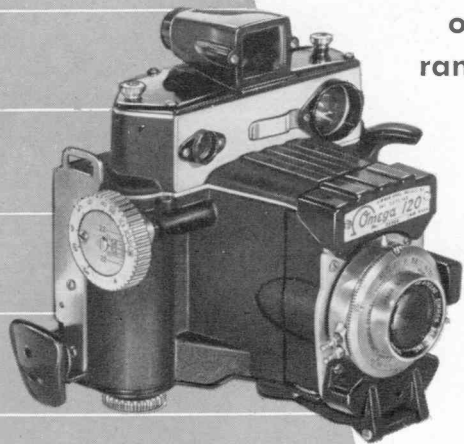

And check what flash photography means to you with your OMEGA 120 CAMERA! OMEGA'S new, exclusive magazine repeater flash gun changes bulbs automatically! The Omegaflash gun is connected to the instant automatic shutter-setting and film winding devices. The large fast-action release lever on the left snaps the picture while actuating the film pressure plate. The synchronized shutter accepts SM bulbs, No. 5 bulbs and electronic flash.

The science of human engineering and common sense, based on long years of experience, determined the functional shape and light weight (just slightly over 2½ pounds) of the OMEGA 120 CAMERA. There are only a few control knobs, but each is very large. The release lever, with its exclusive "rifle-trigger" action is obvious and completely accessible. Yes, you can easily take pictures with your OMEGA 120 while wearing the heaviest gloves! You will like the sound design of the hand grip on the left side of the OMEGA 120 CAMERA, molded to fit the inside of your hand for a sure, steady, firm hold within relaxed reach of the shutter release. Of course, this leaves your right hand free for easy, rapid and accurate focusing so that you actually have an efficient, *Two-Hand Operation Camera*.

**automatic
repeater
flash**

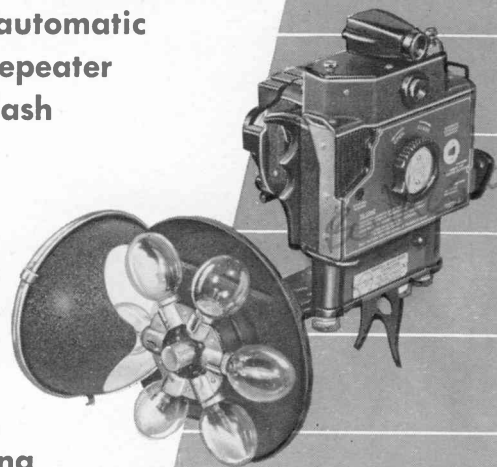

**easy
handling**

**simple
functional
design**

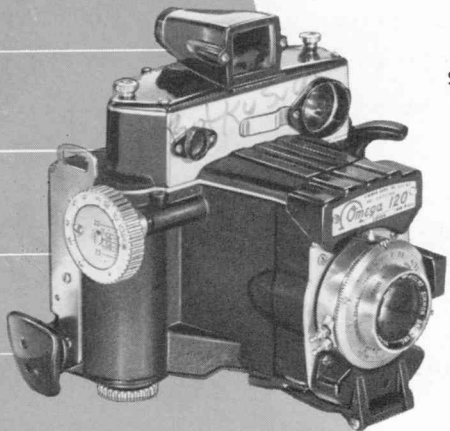

**simple to
operate**

Functionally designed, the OMEGA 120 CAMERA has camera beauty and styling all its own, a distinct departure that you'll discover means remarkable practicality . . . it looks practical and business-like, very much like a small aerial camera. The all-metal camera body is of die cast magnesium. Trim, smaller parts, and camera accessories are of aluminum, stainless steel, molded nylon and of high-impact Phenolic (similar to that used on telephone receivers). The entire instrument is completely and carefully rust and corrosion-protected.

WHAT A PLEASURE TO USE! Remember . . . the OMEGA 120 CAMERA is extremely simple to use, which is always an advantage, regardless of whether you are a photographic expert . . . perhaps a press or magazine photographer . . . or whether you are a novice just getting interested in photography. In either case, it will take you approximately 15 minutes to familiarize yourself with the operation of the OMEGA 120 CAMERA to the point where you can produce top notch results. The operation of the OMEGA 120 CAMERA is so simple as to make an instruction booklet almost superfluous. Consequently, the few following points of information may be digested in a matter of minutes.

contents

- 1. Guide to the Omega 120 Camera**
- 2. Loading**
- 3. Setting Shutter Speeds and Diaphragm Opening**
- 4. How to Hold the Omega 120 Camera**
- 5. Focusing:
Range and Viewfinder
Depth of Focus Scale**
- 6. How to Trip the Shutter**
- 7. Advancing Film**
- 8. Removing Film from Camera**
- 9. Flash**
- 10. Flashguide attachment and carrying cases**
- 11. Filters and Sunshade**
- 12. Close-up Attachment**

1 guide to the **omega**

120

IMPORTANT:

View Finder (14), connected with the automatic Parallax Compensation, should not be forced down when in a raised position.

The Camera Back (18) and Locking Knob (21) are automatically locked in all positions of the counter (19), except when it reads "Open." This prevents accidental exposure of film in the Camera by prematurely removing the back.

The Autofilm Transport (16) can be reversed only at the end of its stroke. This makes incomplete film winding between exposures impossible.

Fig. 1

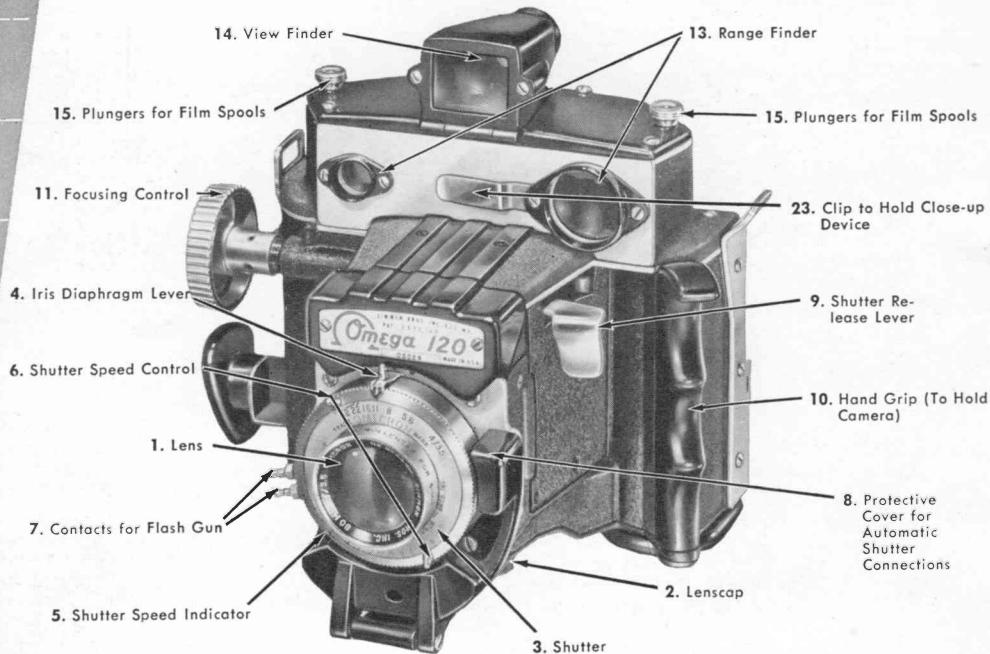

1. Lens
2. Lenscap
3. Shutter
4. Iris Diaphragm Lever
5. Shutter Speed Indicator
6. Shutter Speed Control
7. Contacts for Flash Gun
8. Protective Cover for Automatic Shutter Connections

9. Shutter Release Lever
10. Hand Grip (To Hold Camera)
11. Focusing Control
12. Depth of Focus Scale
13. Range Finder
14. View Finder
15. Plungers for Film Spools

16. Autofilm Transport (Pull out straight and return)
17. Starting Knob (To be used for Frame No. 1 only)
18. Camera Back
19. Exposure Counter
20. Starting Window (For

- initial winding of Film until No. 1 appears in window)
21. Locking Knob (To Lock Back)
22. Back-Cover Lock Pin
23. Clip to Hold Close-up Device

Fig. 2

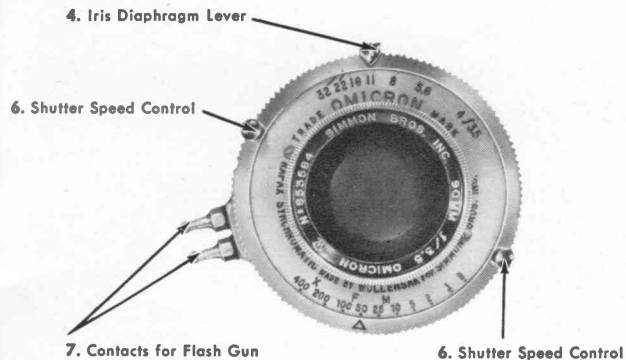

Fig. 4

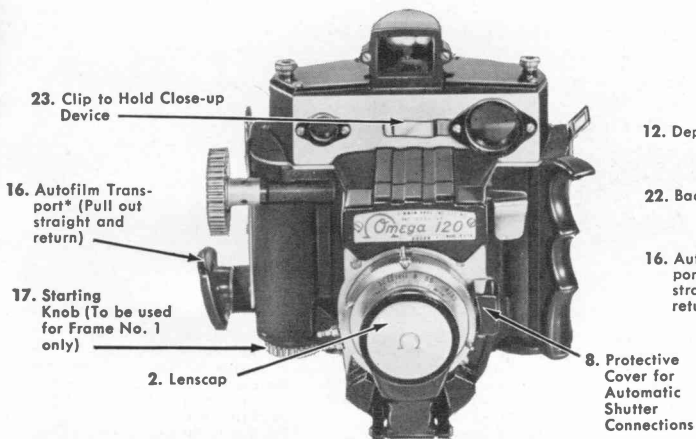

Fig. 3

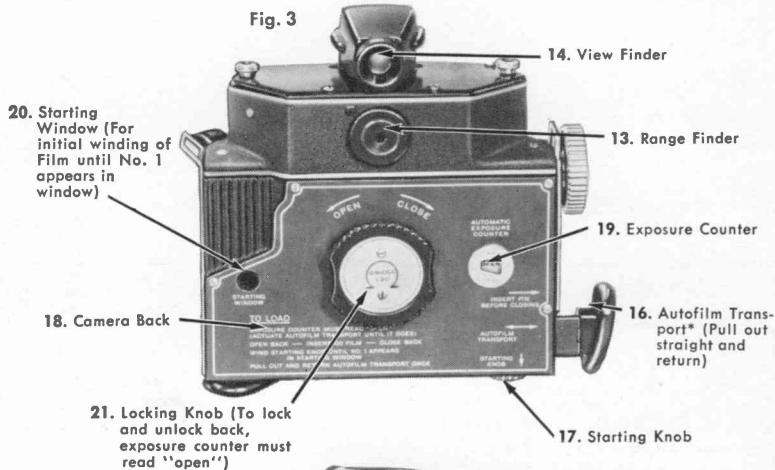
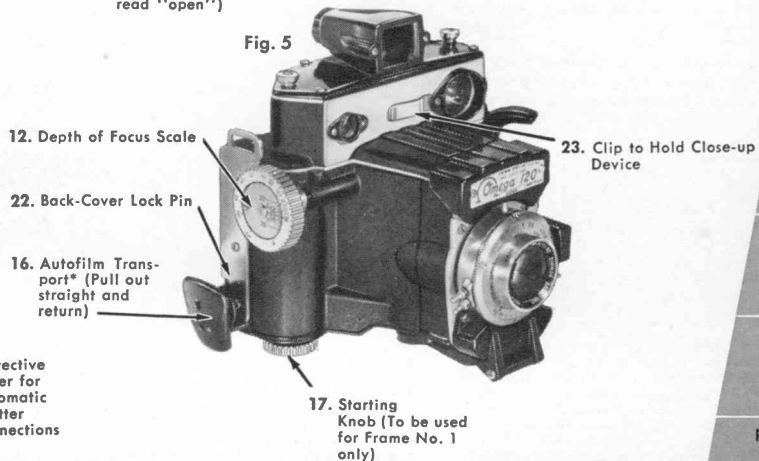

Fig. 5



* Do not remove Camera Back when Autofilm Transport is extended.
 Do not operate Autofilm Transport when Camera Back is removed from camera.

2

how to load the omega 120 camera . . .

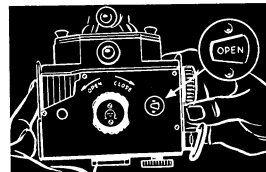

1. Look at counter. If it reads "OPEN"—O.K. If not, pull the Autofilm Transport (repeatedly if necessary) until it does.

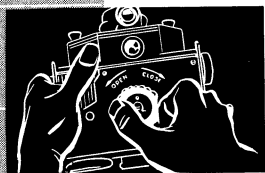

2. Open back. Turn Locking Knob counter-clockwise.



3. Lift left side of back first. Pull out towards the left.

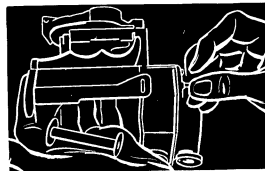

4. If a spool is in the right pocket and the left pocket is empty—O.K. If spool is in the left pocket, remove it by inverting camera, pulling plunger and letting spool drop into palm of your hand.

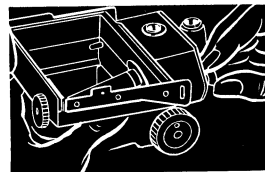

5. If right pocket is empty, insert empty spool. Insert film key into slotted end of spool while other end rests (under an angle) on inside end of plunger. Pull plunger causing spool to drop into pocket.



6. Inserting Film. Remove the gummed paper from loaded spool and insert spool in left pocket. Insert lower end first, upper end of spool resting on inside end of plunger. Pull plunger causing spool to drop into pocket. During this and the following operation keep one finger on spool to prevent unraveling of film.

Do not remove Camera Back when Autofilm Transport is extended. Do not operate Autofilm Transport when Camera Back is removed from camera.

PERFORM OPERATIONS 4 to 9 in subdued light or in the shade—NEVER in direct sunlight



7. Pull covering paper across camera aperture and thread into empty spool in right pocket. Turn winding knob at lower right corner of camera two or three times to make sure paper is securely attached to spool. Guide paper with one or two fingers so that it is wound straight and tight.



8. Re-insert camera back. Insert back cover lock pin on lower right, back being tilted (low on right and high on left side). Press back into its seat.

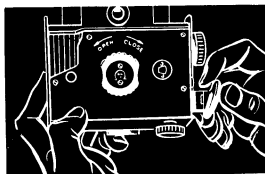

9. Move Autofilm Transport slightly ($1/8$ "') to make sure that gear is in mesh with rack. Turn Locking Knob clockwise.

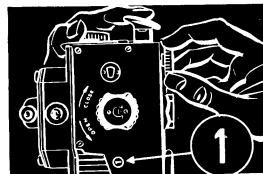

10. Completing the loading. Start winding film, using Starting Knob at lower right corner. Stop winding when number 1 begins to appear in Starting window, on left side of camera back.

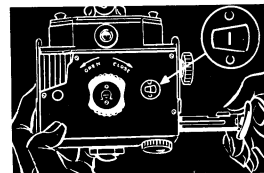

11. Pull Autofilm Transport ONCE and return. This closes starting window and advances film counter to number 1.

how to set shutter speeds and diaphragm openings . . .

3

After the Omega 120 has been loaded with film, it is ready to take pictures. For a correctly exposed picture a definite amount of light must be admitted to the film during an exposure. This amount of light can be controlled in two ways; by adjusting the speed of the shutter and by controlling the iris diaphragm of the lens.

The speed of the shutter is controlled by turning its rim. This is facilitated by two small projections which are shown in Figure 2, page 9 and Figure 2A, Page 10 as No. 6. The diaphragm stop is adjusted by lever (4) also visible on Figures 2 and 2A.

It will be clear that several conceivable combinations of shutter speeds and diaphragm stops may admit the correct amount of light. The choice of the best combination depends upon the following four factors:

- a. Prevailing light conditions
- b. In case of a moving object, the speed of the object to be photographed
- c. The required depth of focus
- d. The ability of the individual operator to hold the camera steady

In order to judge the prevailing light conditions, the use of an exposure meter is recommended. The most frequently used makes are Weston and General Electric and by following the instructions of these manufacturers, proper exposures can be obtained without difficulty.

It is obvious that the speed of a moving object has a definite bearing upon the choice of the speed of the shutter and that a fast moving object calls for a high shutter speed.

For an object which moves slowly or is stationary, we have, of course, a wider choice of speeds. Here we must sometimes make use of "Depth of Focus." This term describes the ability of a lens to produce sharp images, not merely of objects at a definite distance from the camera but also of objects at a somewhat smaller or greater distance. Theoretically, a lens can be focused at any time only at one very definite distance and all objects at a smaller or larger distance will appear unsharp. The transition is gradual and, therefore, within a certain zone acceptable sharpness may be obtained of all objects lying between a certain minimum and certain maximum distance. The width of this zone can be controlled by adjusting the iris diaphragm. The further we stop down, the wider this zone will get. For objects which have a very extended depth, the iris diaphragm stop may become so small that a very slow shutter speed must be used in order to obtain adequate exposures. In such cases, the camera should be placed on a tripod. The use of the "Depth of Focus" scale is explained on page 15. 14

depth
of
focus

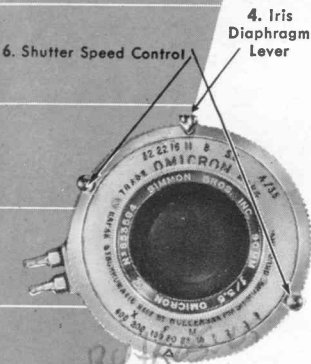

Fig. 2 A

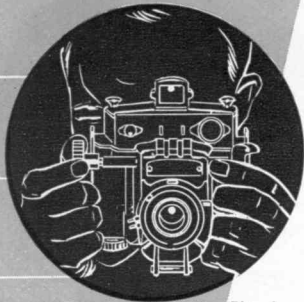

Fig. 6

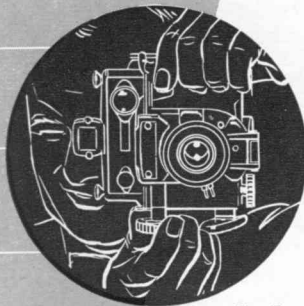

Fig. 7



Fig. 8

4 how to hold the omega 120 during exposures . . .

The left hand of the operator should hold the camera firmly by the convenient handle (10) attached to the left side. The trigger finger of the left hand should be placed in front of the release lever (9). The thumb of the left hand should be placed in the thumb rest at the left upper corner of the camera back. The thumb and trigger fingers of the right hand should actuate the focusing control (11) while the Autofilm Transport (16) should rest on the lower part of the right hand thumb. The camera should then be pressed firmly against the face of the operator in such a position that one of his eyes can observe either the range finder or the view finder. These conditions are shown in Figures 6, 7, and 8.

The camera should not be held in mid air because this is very likely to cause vibrations

during the exposure. The Omega 120 Camera can obtain far sharper pictures than ordinary cameras. This ability is not only due to the special photographic advances built into the camera, but also the functional design which makes the Omega 120 so easy to hold with steadiness. Do not underestimate the importance of holding the camera steady during exposures. Because pictures with the Omega 120 are capable of being precision sharp, small vibrations can adversely affect the detailed image.

For vertical exposures, the Omega 120 can be held in a very similar manner except that the left hand holding the hand grip is placed above the right hand actuating the focusing knob. Again the camera is pressed firmly against the operator's face as shown in Fig. 7.

5 focusing — how to use the view and range finders . . .

The view finder and range finder of the Omega 120 are purposely formed by separate optical systems. This is desirable for best performance and sensitivity. The view finder must present to the observer the entire field to be photographed, necessarily at a *reduced* scale. However, the range finder must, for best sensitivity, show the center of the image at an *enlarged* scale. Since one system calls for magnification and the other for reduction, they obviously cannot be combined without impairing the performance of the range finder.

view finder

The view finder is an inverted telescope (inverted because it is reducing instead of magnifying) which shows the scene to be photographed at approximately two-thirds of its actual size. It is fastened to the top of the Omega 120 by a hinge which forms part of an automatic parallax compensation. (The term "parallax" describes the small but not negligible difference between the view finder image and the image formed by the camera lens upon the film when the camera is focused at distances smaller than infinity. This difference is caused by the fact that the view finder is displaced or offset relative to the optical axis of the camera lens.) The automatic parallax compensation tilts view finder slightly when the focusing mechanism of the camera is adjusted to distances smaller than infinity.

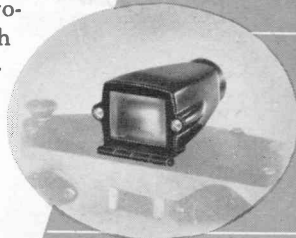

Fig. 9

5 focusing (continued)

range finder

The range finder consists essentially of a telescope with approximately $1\frac{1}{2}$ times magnification and a reflecting system which includes a beam splitter formed by a half transparent mirror. Two images are seen superimposed upon each other; i.e., objects are seen with double contours. When the focusing movement of the Omega 120 is actuated by turning the focus control (11), one of the images shifts automatically. When both images are in coincidence; i.e., when an object is seen with single rather than double contours, the camera is accurately focused upon this object.

For stationary objects, it is best to focus through the range finder first and then to frame the picture carefully in the view finder to get the best compositions.

When photographing moving objects, the scene should be framed approximately through the view finder first. The moving object should

then be observed through the range finder until the actual exposure is taken. As an alternate method, it is sometimes possible to pre-focus the Omega 120 at some suitable distance and then let the object "walk" into the field. In either case, observing the object through the range finder will enable the operator to snap the picture when the two images in the range finder coincide. When photographing moving objects, some allowance must be made for the time lapse between the precise moment the operator decides to snap the picture and the instant he actually snaps it.

The shutter release of the Omega 120 Camera has purposely been designed with a relatively long stroke. Since less pressure is required with a long stroke than with the usual short stroke, a much "softer" release has been achieved. The danger of vibrations during the exposure has thereby been further minimized.



Fig. 10 eyepiece



Fig. 11 front view

5 focusing (continued)

The *Depth of Focus Scale* is arranged within the focusing control (11) as shown in Figures 12 to 14. It has a number of lines symmetrically disposed with respect to a center line; each pair of these lines being marked with an *f* number or diaphragm stop. Its use can be explained as follows:

depth of
focus
scale

1. Focus at the nearest object which should still appear on the negative with acceptable sharpness (Fig. 12). This distance may be, for example, 8 feet.
2. Then focus on the farthest object which should still appear on the negative with acceptable sharpness (Fig. 13). This distance may be, for example, 10 feet.
3. Then move the focusing control to the position shown in Fig. 14 in which the numeral 8 on the footage scale appears just as much above the zero line as the numeral 10 below it. It can be seen that the numeral 8 points at the upper line marked 5.6 on the Depth of Focus Scale. This indicates that in this case all objects from 8 to 10 feet are rendered with acceptable sharpness if the diaphragm is stopped down to $f/5.6$.
4. Then consult your exposure meter and find out at what speed a satisfactory exposure can be obtained with $f/5.6$.

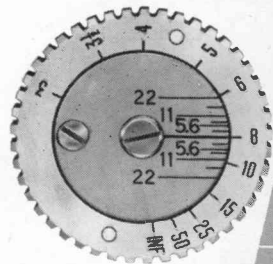

Fig. 12

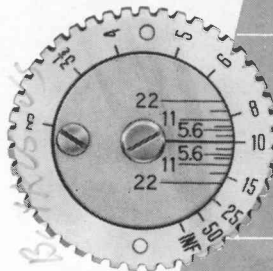

Fig. 13

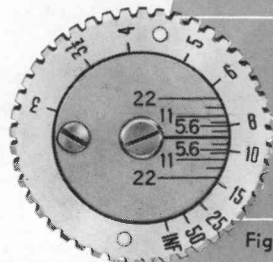

Fig. 14

6 how to trip the shutter . . .

the
release

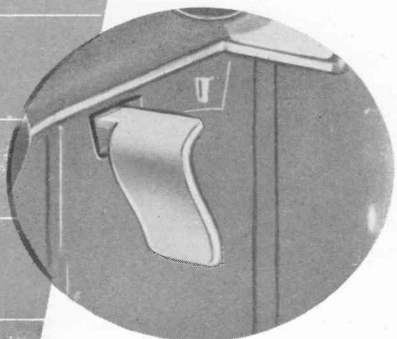

Fig. 15

cable
release

For exposures with a hand-held camera, the release is actuated by the trigger finger of the left hand. This release requires a movement of approximately $\frac{3}{4}$ ". During the first portion of this movement, a pressure plate within the camera is caused to press the film firmly against an accurately machined aperture plate disposed at the proper distance from the lens. This feature keeps the film flat and accurately positioned and is to a large extent responsible for the superior sharpness of pictures taken with the Omega 120. Further movement of the release lever then releases the shutter taking the actual exposure. Experience will teach the operator just how far he can move his trigger finger before the exposure takes place. The release must not be pulled too hastily. Pull without undue camera movement, particularly when using slower speeds.

A cable release is available for time exposures when the camera is placed on a tripod. This device consists of a small bracket and the cable release proper which is fastened to the left side of the camera (next to the release lever) by a small knurled screw. It is prevented from rotating by a small pin which engages a corresponding hole in the side plate of the camera. When taking time exposures it is advisable to actuate the release trigger *but not too slowly*, particularly when using the cable release. (If the trigger is released too slowly while in this position, the shutter may fail to stay open.)

7 advancing the film...

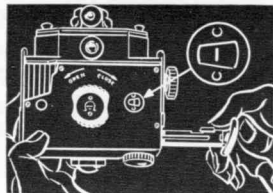

After the exposure, pull the Autofilm Transport (16) out to the stop and push it back. This will not only advance the film but will also automatically reset the shutter for the next exposure. It is necessary to move the transport all the way out before the stroke can be reversed. This movement should be done with care and not too fast and particularly without jerking. Please keep in mind that this method of resetting the camera is exceedingly fast and even if done slowly, it is still much faster than any other method.

**Do not remove Camera Back when Autofilm Transport is extended.
Do not operate Autofilm Transport when Camera Back is removed from camera.**

8 removing the film from the camera...

After exposure No. 9 has been taken, pull the Autofilm Transport (16) four times (and not too fast) until the word "open" appears in the window (20) of the exposure counter; turn the Starting knob (17) 2 or 3 times; then turn Locking knob (21) counterclockwise thereby unlocking the camera back. Detach the camera back lifting the left side first by means of locking knob (21). Invert the camera (so that the lens points upward). Rest camera on either open hand, your hand being beneath the pocket which contains the finished film spool. Pull the plunger (15) and let the film spool with the film drop into your hand.

9 flash . . .

**shutter
synchroni-
zation**

Shutter speeds of 1/400 and 1/200 sec. (marked X) are synchronized for electronic flash (with zero time delay).

Shutter speeds of 1/100 and 1/50 sec. (marked F) are synchronized for Type SM or SF Flash Bulbs (with time delay of approximately 5 milliseconds).

Shutter speeds of 1/25 and 1/10 sec. (marked M) are synchronized for No. 5 Flash Bulbs (with a time delay of approximately 20 milliseconds).

**flash
attachment**

There is a large number of flash attachments (battery cases) available which will work properly with this camera. A flash attachment consists of a reflector, a lamp socket and a container with a battery. It has an electrical connector which must be connected to the contact (7) of the shutter. Do not use any of the older types of synchronizers which contain a mechanical or electrical mechanism to release the shutter itself. The shutter should be released as described in section 6 by means of the release lever (9).

**Omegaflash
unit
for rapid
sequence**

A particularly rapid way to use an OMEGA 120 CAMERA with flash is provided by the Omegaflash Unit which makes a very rapid succession of flash pictures possible because it automatically changes its own lamps after each picture.

The Omegaflash consists of a housing which can be attached to the lower surface of the camera. It contains not only the batteries and a capacitor but also a gear mechanism which is engaged to the film winding knob (17). On one side of the housing is a reflector and a rotating lamp turret which accepts six lamps and which is rotated automatically after each picture while the operator changes the film by pulling the Autofilm Transport (16) in the customary fashion.

To provide a base upon which the Omegaflash Attachment can stand, snap out folding support (29). To return support (29) to rest position, depress spring lever immediately adjacent to the support.

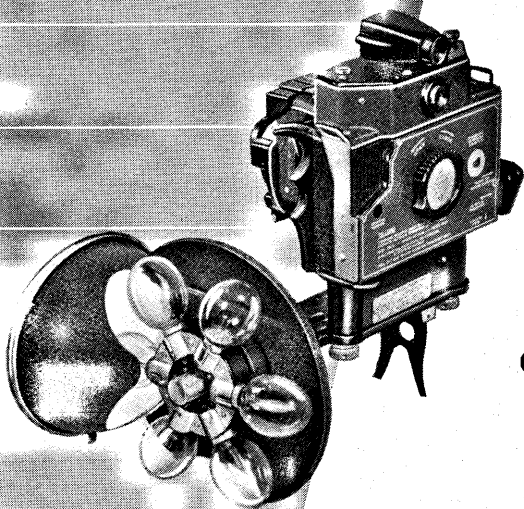

OMEGA 120 CAMERA

with fully synchronized shutter



Page 17 of the instruction booklet on the OMEGA 120 CAMERA refers to the shutter synchronization. It was written for a so-called XFM shutter which can be used with strobe lights, with Type SM or SF Lamps, and with No. 5 and similar lamps at **SELECTED** shutter speeds.

We are now supplying, as optional equipment, a so-called fully synchronized shutter which can be used with strobe lights, Type SM or SF Lamps, and No. 5 and similar lamps at substantially **ALL** shutter speeds.

This shutter has an additional dial on the left side. This dial has three positions: one marked FX (F in red and X in black), one marked M in red, and one marked M in black. These markings denote the following:

In the first position (FX) the shutter is synchronized for strobe lights at all shutter speeds. In the same position the shutter is also synchronized for Type SM or SF Flash Bulbs (with a time delay of approximately 5 milliseconds) at shutter speeds of 1/50 of a second or slower which are marked in red on the shutter speed dial.

The two positions marked M are to be used for No. 5 Flash Bulbs or similar lamps (with a time delay of approximately 20 milliseconds). The position marked M in red is again to be used for shutter speeds marked in red on the shutter speed dial, i.e., 1/50 of a second or slower, and the position marked M in black is to be used for shutter speeds marked in black on the shutter speed dial, i.e., 1/100 of a second or faster.

how to
attach the
Omegaflash
attachment

The flash gun is fastened to the camera by means of a screw which engages the thread otherwise used for the tripod. This screw can be rotated by a small knob (26). See Fig. 18. When the flash gun is attached to the camera, attention must be paid to a small pin (25) which engages a corresponding hole located near the film winding knob. This pin keeps the flash gun from rotating. The gear mechanism is engaged to knob (17) by means of two prongs which enter corresponding holes within knob (17). A knurled knob (26A) permits the rotating of knob (17) after the flash gun has been attached to the camera. It is, therefore, possible to load the camera in the customary way without detaching the flash gun. Instead of turning knob (17) for the initial film winding, knob (26A) is used.

lamp
turret

The lamp turret is visible in Fig. 20 and can be attached to the threaded end of the rotating shaft (27) by means of knurled knob (28). (Turn in a clockwise direction.) The lamp turret contains six lamp sockets of conventional design which can be loaded with flash lamps in the usual manner; i.e., the two pins on either side of the lamp socket enter corresponding slots, the lamp is depressed and slightly rotated in a clockwise direction. Occasionally when the lamp turret is attached to the flash gun, the lamp within the reflector will not be exactly in its center. In this case, the entire turret can be rotated in a clockwise direction until one of the lamps is in the proper position. (No great accuracy is required.) It will be found that the turret is held with some slight friction which can be easily overcome.

NOTE: Always attach transparent Safety Shield (33)
to flash gun before using

www.orphancameras.com

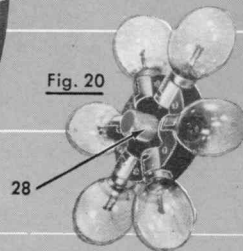
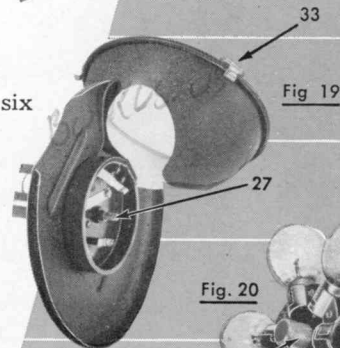
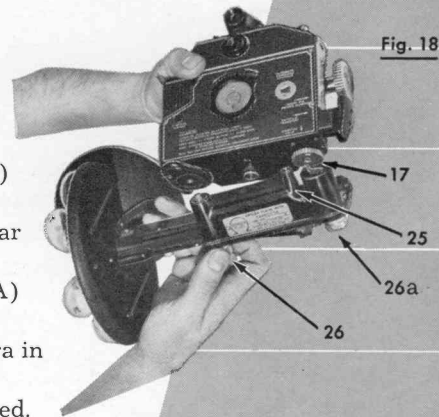

9 flash . . .

(continued)

lamp turret (continued)

Whenever the operator resets the camera by means of pulling handle (16), the lamp turret will make 1/6th of a revolution placing a fresh lamp into the center of the reflector. (NOTE: The relatively large cutout of the reflector causes only a very slight loss of light. Approximately 60% of the light falling upon an object comes from the lamp itself and approximately 40% from the reflector. The cutout causes less than 1/4 of the 40% to be lost; i.e., no more than 10% of the total light, which is negligible.)

The ease with which the lamp turret is attached to or detached from the flash gun by the knurled knob (28) means even greater rapidity, convenience and continuity in using flash. An extra turret may be pre-loaded with flash lamps. The loaded turret replaces the used turret enabling the operator to take another set of rapid sequence flash exposures.

The flash gun is equipped with a folding support (29) which permits the flash gun and the camera together to be placed conveniently upon a flat surface when not in use.

Since this flash gun is equipped with a capacitor, batteries do not require renewal for long periods of time. When the occasion does arise, however, remove the lower cover from the flash gun, as shown in Fig. 23, whereupon the batteries become easily accessible. Three batteries are used, size A-A, manufactured by most battery manufacturers (9/16" dia., 1 7/8" long, 1 1/2 volts).

Be sure that the batteries are inserted in the proper direction. A corresponding inscription showing this direction is found on the inside of the flash gun housing.

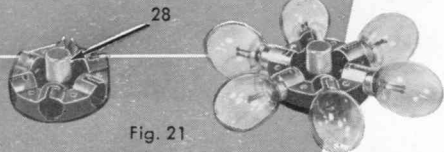

Fig. 21

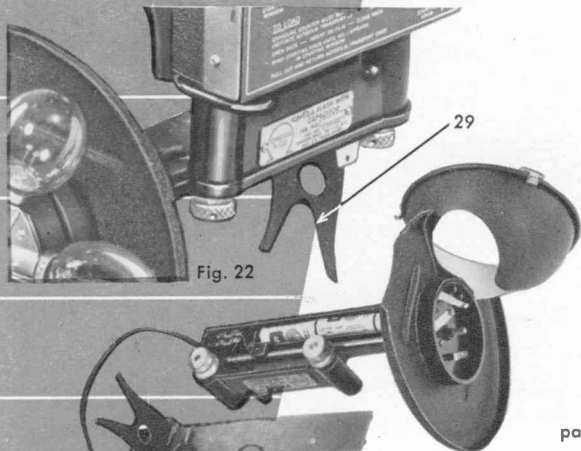

Fig. 22

Fig. 23

10 direct reading flash guide attachment and carrying cases...

Direct Reading Flash Guide Attachments are valuable and practical flash accessories that completely eliminate the necessity for consulting a conversion table in order to find the correct lens-opening for a given distance. They slip over the large focusing knob and cover the distance scale and in its stead show a scale of lens-openings so that the red indicator automatically points out the correct one right after focusing. Direct Reading Flash Guide Attachments are available for various film speeds as follows:

#A - 1/50-1/100 sec. ASA 50-80 (Super XX) SM Bulb.

#B - Blank to fill out to suit individual requirement.

#C - 1/50-1/100 sec. ASA 25-40 (Plus X, Verichrome) SM Bulb.



carrying cases

LEATHER CAMERA CASE (C103). Made of finest saddle-stitched tan saddle leather for OMEGA 120 CAMERA, Filters, Sunshade, other accessories, including adjustable shoulder strap.

LEATHER CARRY-ALL CASE (C133). Made of finest saddle-stitched tan saddle leather with special fittings for OMEGA 120 CAMERA, Omegaflash Attachment, Spare Turret, and all accessories including spare bulbs and film.

ALUMINUM CARRY-ALL CASE (C135). Satin Finished aluminum case by Halliburton, with special fittings for OMEGA 120 CAMERA, Omegaflash attachment, Spare Turret, and all accessories including spare bulbs and film.

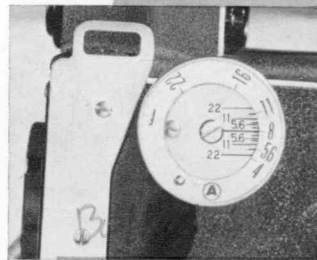
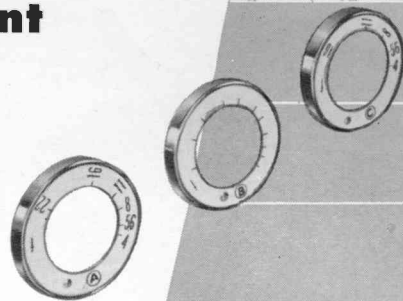

11 filters and sunshade . . .

filters

For black and white Panchromatic Film, generally only a very light yellow (K-1) or green filter is needed and even that can often be dispensed with. We caution against the use of unnecessarily heavy filters because they will usually not improve pictorial quality and merely prolong the exposure time. It does not follow that if a weak yellow filter is good, a strong yellow filter will be better.

For color pictures a so-called "Skylight" filter must be used. (This is a colorless filter that absorbs excess ultraviolet light without causing extension of the exposure time.)

The use of a sunshade is strongly recommended, particularly for pictures against the light. It prevents oblique light rays from striking the lens surface and causing unnecessary glare within the lens which, in turn, produces an overall fog over the entire picture. Simmon Brothers have designed a special sunshade for the Omega 120 Camera. A filter (32) may be set directly into the distinctive sunshade and is held firmly in position by knurled knob (30). This arrangement allows the operator to utilize both sunshade and preferred filter simultaneously for exposures. To change filters without detaching the sunshade from the camera, simply loosen the knurled knob (30). When using the sunshade without a filter, the sunshade adapter (31) sits into the filter rim and easily fits the unit onto the camera.

Fig. 24

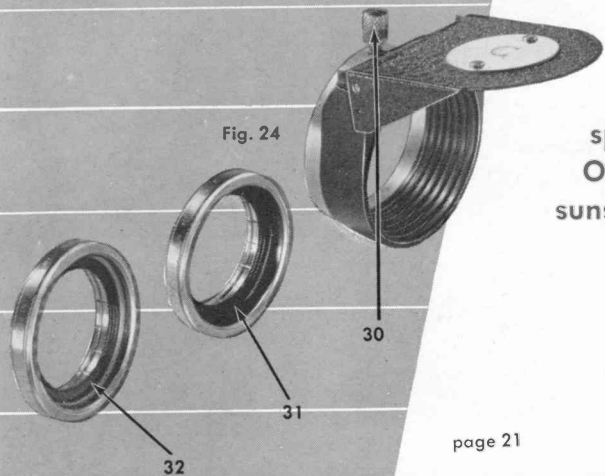

special
Omega
sunshade

12 close-up attachment . . .

The Close-Up Attachment consists of two parts; a supplementary lens to be placed in front of the camera lens itself and an adaptor which changes the range finder and view finder characteristics in a suitable manner. This adaptor is placed in front of the smaller window of the range finder by means of a clip (23). Part of this adaptor is a small prism or wedge which deflects the beam of the view finder in accordance with the closer distance of the object. Another unit in the adaptor is a deflection device which changes the base distance and the direction of one beam of the range finder.

When the camera is equipped with these accessories it can be focused upon objects at distances of from 18" to 36". The object is observed through the view finder or range finder respectively in the customary manner and focusing is done in the usual way by turning a focusing control (11). The footage scale on focusing control (11) as well as depth of focus scale (12) must, of course, be disregarded because their readings are now meaningless.

Attention is called to the fact that at this close distance, the depth of focus is quite small and that it is, therefore, very desirable to use as small a stop of the iris diaphragm as possible. This, in turn, means that often artificial light will have to be supplied in order to make this possible, either by means of flash or by means of a sufficiently high-powered lamp, unless the object can be taken in reasonably bright sunlight.

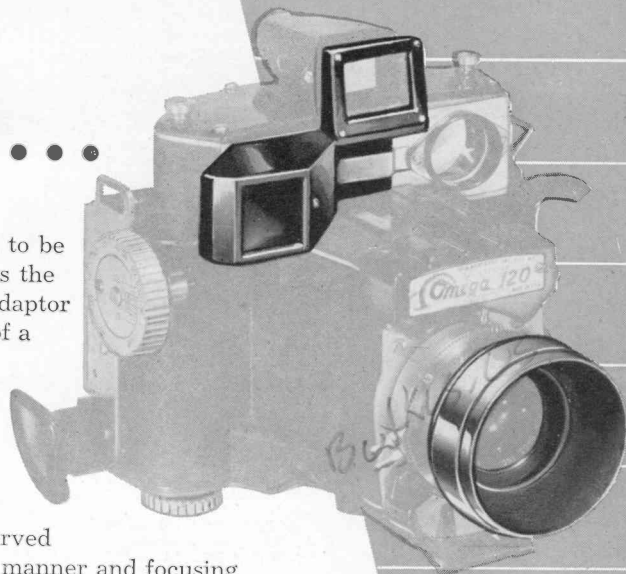



omega



**SIMMON BROTHERS, INC.
ARE ALWAYS AT YOUR SERVICE**

Any OMEGA 120 CAMERA owner with recommendations, questions, problems or in need of service should contact our Technical Expert, Mr. Walter Archinal.

Telephone STillwell 6-2220 or write Mr. Archinal in care of

SIMMON BROTHERS, INC.
30-28 Starr Avenue
Long Island City 1, N. Y.

PRINTED IN U.S.A.