

This manual is for reference and historical purposes, all rights reserved.

This page is copyright© by M. Butkus, NJ.

This page may not be sold or distributed without the expressed permission of the producer

I have no connection with any camera company

On-line camera manual library

This is the full text and images from the manual. This may take 3 full minutes for the PDF file to download.

If you find this manual useful, how about a donation of \$3 to: M. Butkus, 29 Lake Ave., High Bridge, NJ 08829-1701 and send your e-mail address so I can thank you. Most other places would charge you \$7.50 for a electronic copy or \$18.00 for a hard to read Xerox copy.

This will allow me to continue to buy new manuals and pay their shipping costs.

It'll make you feel better, won't it?

**If you use Pay Pal or wish to use your credit card,
click on the secure site on my main page.**



Instruction Book

PETRI FTX

MAJOR SPECIFICATION OF PETRI

TYPE;	Pentaprism SLR camera with built-in cross coupled CdS exposure meter in TTL system.
FILM:	35mm. film (20,36 or 12 exposures)
FILM SIZE:	24mm. x 36mm.
STANDARD LENS:	PETRI 55mm. f/1.4, 7 elements in 5 groups (or f/1.8, 6 elements in 4 groups) with fully automatic diaphragm.
SHUTTER:	Focal plane type with speeds, 1 second to 1/1000 second and B. Built-in self-timer.
EXPOSURE METER	Built-in cross coupled CdS exposure meter in TTL system. ASA: 25 to 1600 (DIN: 15 to 33).
VIEWFINDER	Pentaprism viewfinder with "Micromatic Prism Focusing" device.
FILM TRANSPORT	Single stroke rapid film winding and shutter cocking.
SYNCHRONIZATION:	FP and X automatic setting. A hot shoe contact.
LENS MOUNT:	Screw mount.
FILTER SIZE:	55mm. screw-in type (52mm. for f/1.8 lens)
LENS HOOD SIZE:	57mm. push-on type (54mm. for f/1.8 lens)

INDEX

	(page)		(page)
MAJOR SPECIFICATION OF PETRI FTX	1	HOW TO READ THE CHART	19
INDEX	2	FILM LOADING	20
DESCRIPTION OF PARTS	3	FILM UNLOADING	22
PICTURE-TAKING GUIDE	6	HOW TO HOLD YOUR PETRI FTX CAMERA	23
BATTERY FOR THE CdS EXPOSURE METER	8	HOW TO INTERCHANGE THE LENS	24
FILM TRANSPORT LEVER	9	DEPTH OF FIELD	25
EXPOSURE COUNTER	9	HOW TO READ THE DEPTH OF FIELD	25
FILM SPEED (ASA OR DIN) SETTING	10	DEPTH OF FIELD TABLE	26
SHUTTER SPEED DIAL	11	FLASH PHOTOGRAPHY	28
APERTURE SETTING	12	EXPOSURE CONTROL* IN	
DIAPHRAGM SCALE	12	FLASH PHOTOGRAPHY	30
AUTOMATIC/MANUAL OPERATION	12	HOW TO USE THE BUILT-IN SELF-TIMER	31
VIEWFINDER AND FOCUSING	14	INFRA-RED PHOTOGRAPHY	31
UPRIGHT, UNREVERSED IMAGE	14	MAINTENANCE AND CARE OF YOUR	
MICROMATIC PRISM GRID	14	PETRI FTX	32
EXPOSURE CONTROL	16	PETRI ACCESSORIES	33
THROUGH-THE-LENS SYSTEM	16		
COUPLED CdS METER	17		
TO ADJUST THE EXPOSURE CONDITION	18		
SHOOTING AGAINST THE LIGHT	18		
EXPOSURE METER COUPLED RANGE	19		

DESCRIPTION OF PARTS



- ① Film Transport Lever
- ② Exposure Counter
- ③ Shutter Speed Dial
- ④ Accessory Shoe
- ⑤ Cordless Flash Contact

- ⑥ Film Speed Dial
- ⑦ Film Rewind Crank
- ⑧ Diaphragm Button
- ⑨ Shutter Release Button
- ⑩ Self-timer Release Button

- ⑪ Self-timer Lever
- ⑫ Screw Thread for Cable Release
- ⑬ Neck Strap Ring
- ⑭ Battery Compartment

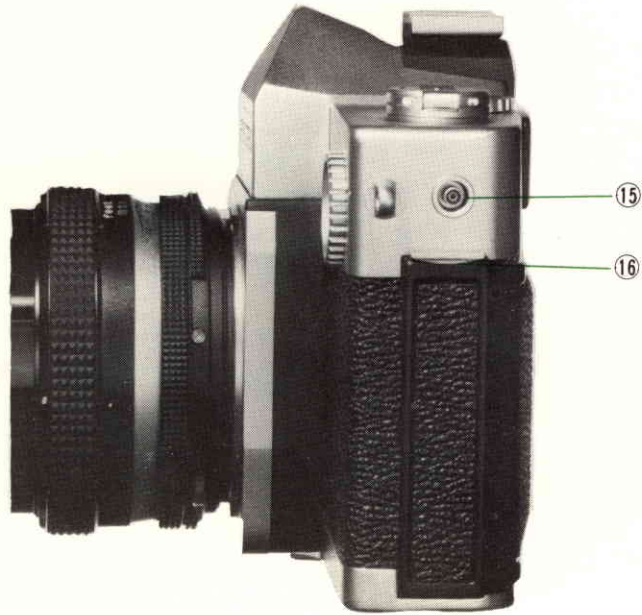

- ⑮ Flash Socket
- ⑯ Back Cover Lock



- ⑰ Distance Scale
- ⑱ Depth of Field Indicator
- ⑲ Diaphragm Scale
- ⑳ Diaphragm pin

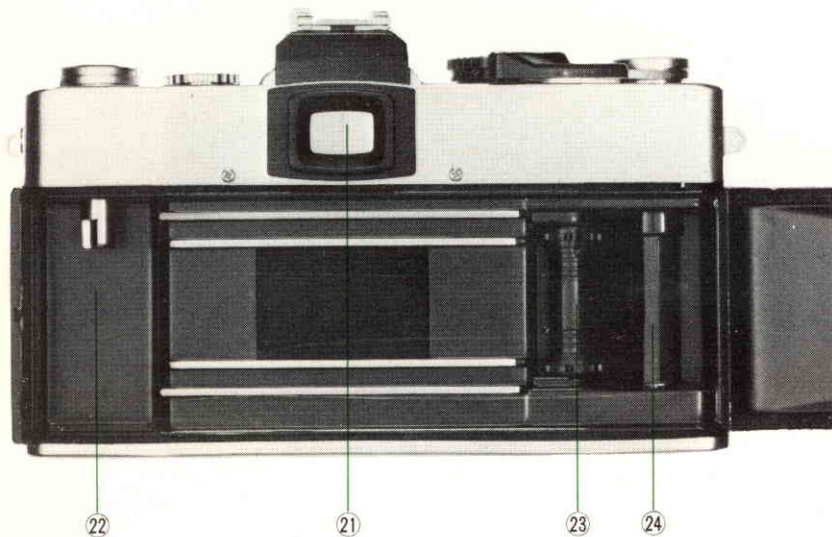

- ②① Viewfinder
- ②② Film Cassette Chamber
- ②③ Sprocket
- ②④ Take-up Spool

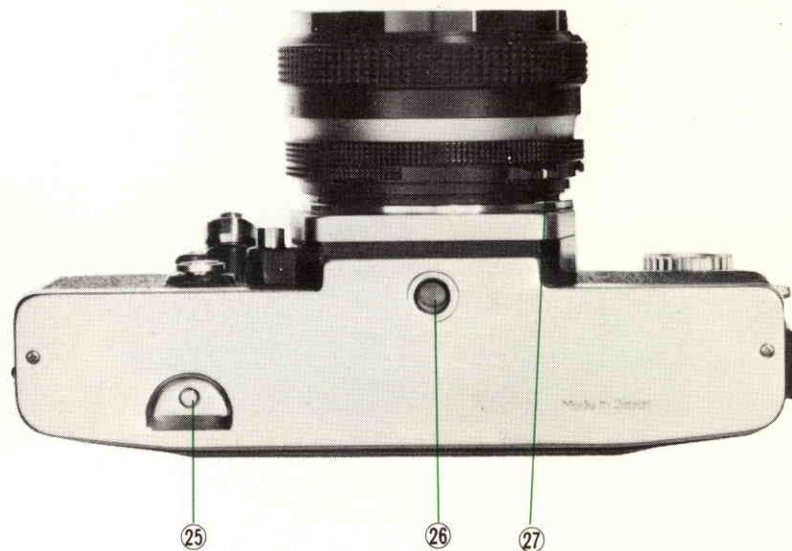

- ②⑤ Film Rewind Button
- ②⑥ Tripod Socket
- ②⑦ Auto & Manual Diaphragm Switch

PICTURE-TAKING GUIDE

The Petri FTX has been especially designed so that picture taking is always a simple, uncomplicated procedure. Even an inexperienced photographer will find it easy to use because there are so few steps — only six, in fact. Actually once the film has been loaded and the film and shutter speed set, there are only three steps to follow in most cases until you reach the end of the film cartridge. Your camera will accept standard 20 or 36 exposure cartridges (or the special 12 exposure ones occasionally available). The information on these pages is intended only for a quick guide. More details will be found in the appropriate pages of this manual.

1. SET THE FILM SPEED

Turn the film speed dial and align the reading equivalent to speed of the film in use with the black line on the right-hand side of the dial.

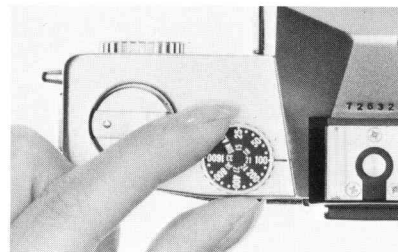

2. LOAD THE FILM

Open the camera back and insert the film cartridge. Insert the end of film leader into the spool slot and engage film perforations to the sprockets properly.

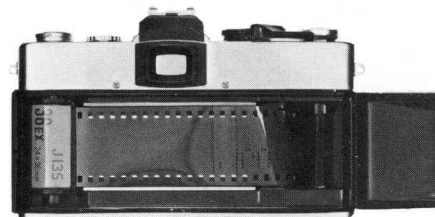

3. ADVANCE THE FILM

Swing the film transport lever and release the shutter twice. Then repeat the operation once more and the shutter is cocked for the first exposure.

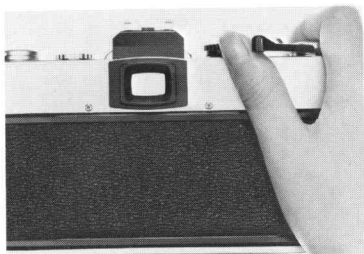

4. SET THE SHUTTER SPEED

Turn the shutter speed dial and line up the appropriate speed with the black line on the base of the accessory shoe.

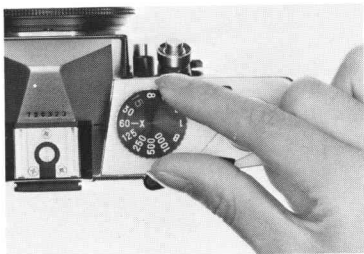

5. EXPOSURE SETTING

Sight through the viewfinder. Depressing the diaphragm button turn the diaphragm ring till the exposure meter needle is centered in the circle.



6. FOCUS AND SHOOT

Turn the focusing ring till the image is seen sharp in the center grid. Squeeze the shutter release button to avoid camera shake.



BATTERY FOR THE CdS EXPOSURE METER

The built-in CdS exposure meter is powered with a 1.3 volt mercury battery of the Mallory PX- 625 or equivalent type. The battery compartment is located on the left-hand front side of the top cover. The exposure meter is switched on by a stroke of the film advance lever. When the exposure meter needle does not respond to a change of light conditions, the battery has become exhausted and must be replaced.

Unscrew the battery compartment cover with your finger tips and insert a new battery with the plus (+) upward, facing the battery compartment cover, into the battery compartment.



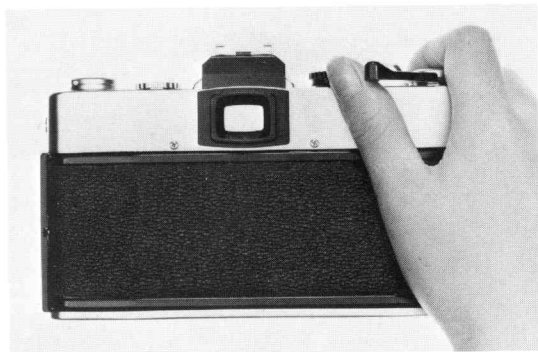

FILM TRANSPORT LEVER

When the film transport lever is advanced, the following things happen simultaneously:

1. The battery switch is turned on and the exposure meter is activated.
2. The film frame is transported to the next unexposed frame.
3. The film counter is advanced.
4. The shutter is cocked.

After the shutter is released, the battery circuit is shut off and unnecessary battery drain is avoided.

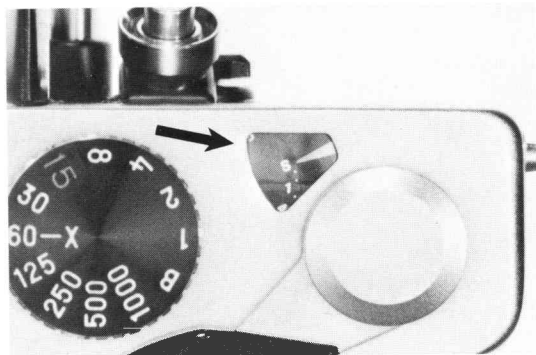

EXPOSURE COUNTER

The counter is located on top of the camera body. It shows the number of film frames exposed, and automatically resets to "S" (for "Start") position when the back cover is opened. Frames of the 12th, 20th and 36th are marked in red to signal end of the roll, depending on the length of the film used.

FILM SPEED (ASA OR DIN) SETTING

After the film has been loaded, be sure to set the ASA or DIN film speed index specified for the film in use on the film speed scale. This adjusts the exposure meter for the film being used and an essential step in getting properly exposed pictures.

To set the film speed, turn the film speed dial and align the reading equivalent to speed of the film in use with the black line on the right-hand side of the dial. Do not set in between click-stops.

The white numbers represent ASA values and range from ASA 25 to 1600, and the red numbers represent DIN values ranging from DIN 15 to 33. Read the instructions supplied with the film and set the correct film speed index number. If the number of the film speed corresponding to that of your film is not available on the film speed scale, use the closest number and never set between two settings. For convenience, the positions for intermediate film speeds are shown only by dots. See the illustration.

ASA	25	●	●	50	●	●	100	●	●	200	●	●	400	●	●	800	●	●	1600
NUMBERS SHOWN BY DOTS	32	40	64	80	125	160	250	320	500	650	1000	1250							
DIN	15	●	●	18	●	●	21	●	●	24	●	●	27	●	●	30	●	●	33
NUMBERS SHOWN BY DOTS	16	17	19	20	22	23	25	26	28	29	31	32							

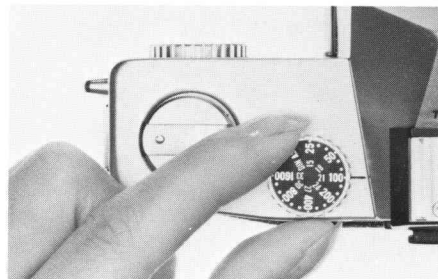
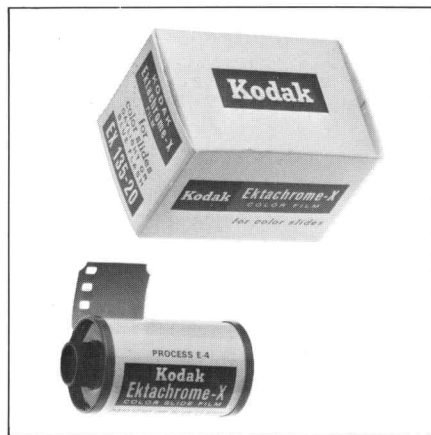

SHUTTER SPEED DIAL

Your camera shutter has a range of speeds covering sufficiently all the ordinary picture situations. It has the settings of: 1/1000, 1/500, 1/250, 1/125, 1/60, 1/30, 1/15, 1/8, 1/4, 1/2 and 1 second and Bulb. When the Bulb setting is used, the shutter stays open as long as the shutter button is being depressed (for time exposure). The settings are represented on the shutter speed dial located right-hand on top of the camera body. For convenience, only the lower half of the numbers (250 for 1/250, etc.) and B (for Bulb) are etched on the black wheel. The shutter speed is set by lining up the appropriate number or B with the black line on the base of the accessory shoe. Do not set the shutter speed between two click-stops. The shutter speed can be selected either before or after the shutter has been cocked. For indoor photography, it is recommended to set the shutter at 1/30 or 1/60; for outdoor photography, at 1/125 or 1/250; and for action photography such as in sports or snap shots it is important to use faster speeds of 1/500 or 1/1000 to avoid blurring.

The number "15" for 1/15 second is larger than others and painted in blue. When using the shutter speeds slower than 1/15 second, it is recommended to use a tripod and a cable release equipment so as to avoid camera shake.

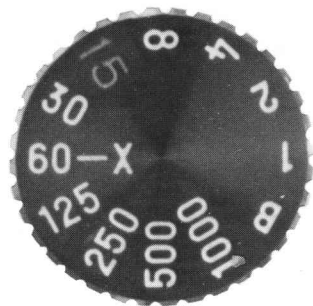
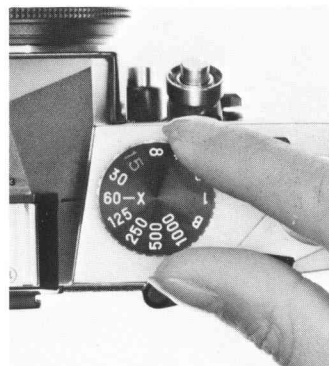

DIAPHRAGM SCALE

The diaphragm scale is located on upper side of the lens barrel.

The aperture opening has eight settings, ranging from $f/1.4$ (seven settings for $f/1.8$ lens, ranging from $f/1.8$), the maximum opening, to $f/16$, the minimum opening.

Settings between $f/stops$ are also possible.

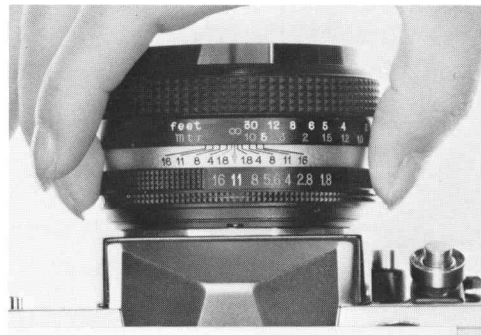

AUTOMATIC/MANUAL OPERATION

There are "A" (short for Automatic) mark in green and "M" (short for Manual) mark in red on the underside of the lens barrel.

Move the auto & manual diaphragm switch (27) to the left, and you will see the diaphragm is set at "A" position. This is the normal position for most circumstances. With the "A"

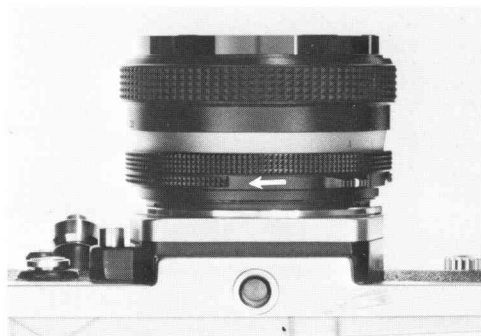

The operation of the automatic diaphragm mechanism:

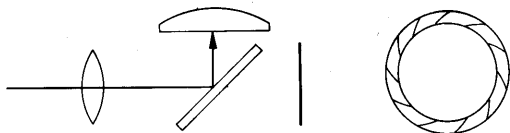

(1) When you are focusing, the diaphragm stays open and the mirror remains in position.

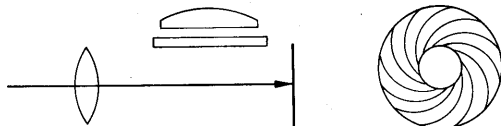

(2) Just before the shutter opens, the lens stops down to the preselected aperture. The mirror moves out of the way.

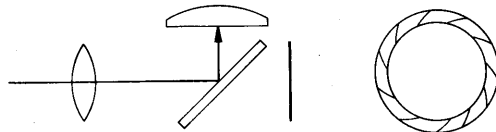

(3) After the exposure, the lens reopens to full aperture and the mirror returns to its original position. The battery circuit is shut off.

position, the diaphragm stops down to the pre-selected aperture just before the shutter is released and opens again after each exposure for easy and accurate focusing. See the diagram. When manual diaphragm is desired, move the auto & manual diaphragm switch to the right. The advantage of the manual operation is that you can pre-view the depth of field and see in the viewfinder the lens zone of sharpness with any aperture. The manual operation also can be obtained simply by pressing the diaphragm buttonⓈ.

UPRIGHT, UNREVERSED IMAGE

As a 35mm single lens reflex camera, the Petri FTX uses a mirror as part of its optical system to transfer the image entering the lens to the viewfinder. In the process, the image which is originally reversed and inverted when it enters the lens is reversed and turned right side up so you see the picture in the viewfinder exactly as your naked eye would.

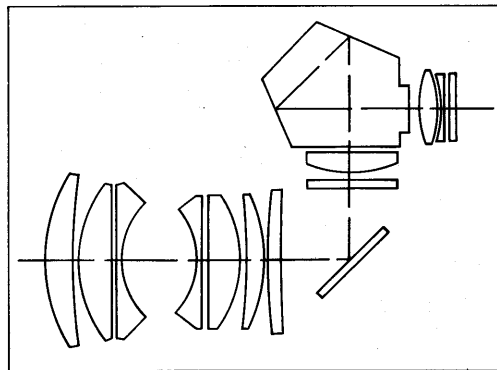

MICROMATIC PRISM GRID

Petri FTX has the original Petri Micromatic Focusing system for fast and accurate focusing. The precision focusing elements in the viewfinder consist of a group of more than 800 micro-prisms as shown in the center of the picture. As you look through the micro-prism area (A) in the viewfinder, you can see the subject clearly, ONLY when it is correctly focused. Rotating the focusing ring you will notice the appearance of

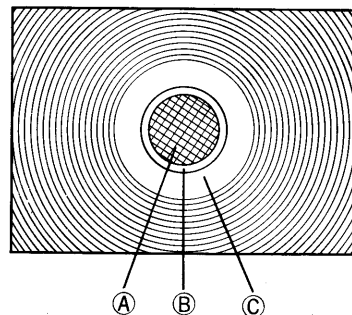



IN FOCUS



OUT OF FOCUS

something like a mesh of a net in the center of the viewfinder. This reticulation is caused by the flickering of reflected light entering the camera lens. When the subject is correctly focused the flickering grid fades away from the micro-prism area. In the second inner circle (B) is the plain glass area where the subject is always seen sharp and clear, even when the lens is out of focus. When the lens is correctly focused the image in the micro-prism area will be as sharp and clear as that seen in the surrounding circle (C).

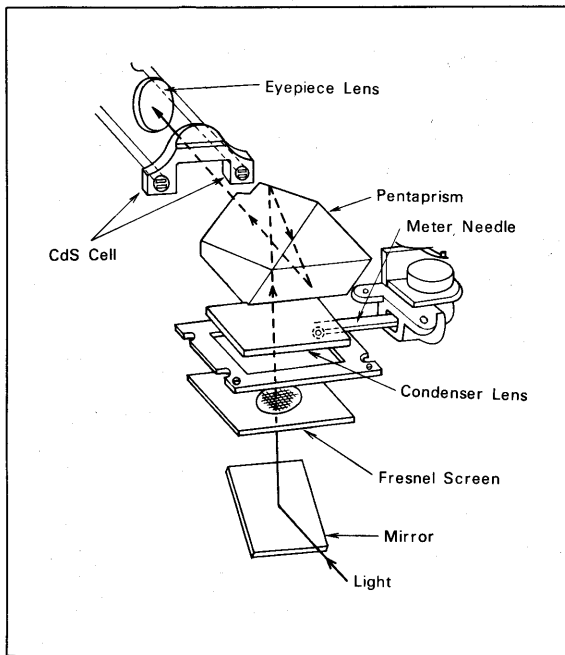

THROUGH-THE-LENS SYSTEM

Your Petri FTX camera has a built-in, through-the-lens exposure control system utilizing the most sensitive measuring devices available in ordinary photography. Two cadmium sulfide (CdS) cells, located on each side of the pentaprism base, measure the average brightness of the image entering the lens and reflected to the viewfinder. This through-the-lens measurement is translated into an accurate exposure indication registered by the needle in the viewfinder. The readings are accurate not only with standard lenses, but also with interchangeable lenses including long ones, with filters, close-up equipment and accessories for photomicrography. Since they actually measure the available light of the image that has entered the camera, calculations for exposure adjustments are unnecessary. The system operates automatically with the lens aperture, shutter speed and film speed settings.

COUPLED CdS METER

The CdS meter of your Petri FTX camera is coupled to the lens aperture, shutter speed and film speed settings.

A change in the setting of any one or more will, therefore, alter the meter reading. It is preferable, of course, to change either the aperture or shutter speed if an adjustment is required. The film speed setting should always be the one for the film you are using.

By advancing the film transport lever, the battery switch is turned on and the exposure meter is activated.

Keep your finger on the diaphragm button (8). (When the diaphragm is being set at the manual operation, there is no need to press the button. Refer to **AUTO/MANUAL OPERATION** at page 12.) And swing the diaphragm scale (19). When the exposure meter needle is centered, the setting is correct.

If the lens aperture is too large or the shutter speed too slow for the available light, the needle in the viewfinder will be above the circle and indicate that the picture if taken, will be overexposed.

If the lens aperture is too small or the shutter speed too fast for the available light, the needle will be below the circle to indicate that the picture will be underexposed.

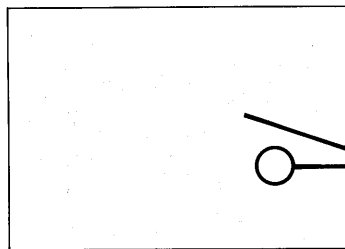

OVER

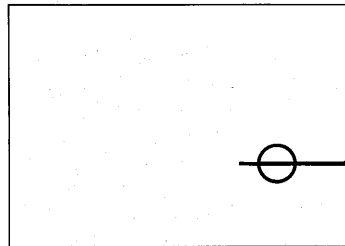

PROPER

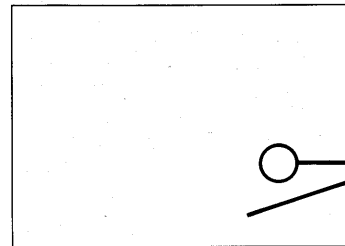

UNDER

TO ADJUST THE EXPOSURE CONDITION

When the main subject of the whole picture area you frame in the viewfinder is extremely dark or bright, it is recommended to adjust the exposure condition so that the important subject is correctly exposed.

If the important subject is comparatively dark, set the f/number at a half or one stop closer to the full aperture than the f/number indicated when the exposure meter needle is centered.

If the subject is brighter, set the f/number at a half or one stop closer to the minimum aperture than the f/number normally obtained. For example, when you take a portrait with a back-ground of snow scene or on the beach, you can get a properly exposed picture by using a half or one stop wider aperture opening than normal.

SHOOTING AGAINST THE LIGHT

When the light is available from the back

of the subject and your main subject is comparatively darker than the back-ground, it is recommended to adjust the exposure condition. The procedure is same as required when the important subject is dark. (Refer to TO ADJUST THE EXPOSURE CONDITION) First, set the exposure in the normal way. Rotate the diaphragm ring to the right and set the f/number at a half or one stop closer to the full aperture than the f/number indicated when the exposure meter needle is centered.

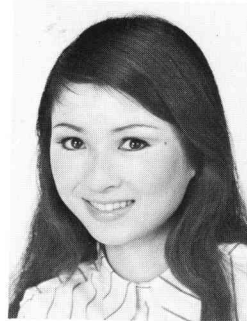

NORMAL LIGHTING

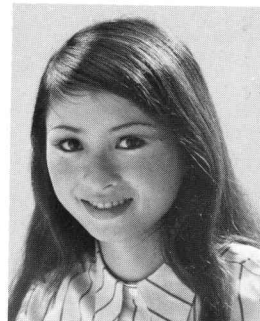

BACK LIGHTING

EXPOSURE METER COUPLED RANGE

Petri FTX has a fully coupled CdS exposure meter which measures optimum exposure conditions Through-The-Lens, ranging from EV 3 to EV 18 with ASA 100 (DIN 21) film.

HOW TO READ THE CHART

The word "EV" stands for "Exposure Value," which represents the brightness on the subject you frame in the viewfinder. The EV is represented by numbers, and exposure meter of the Petri FTX can measure the brightness on the subject ranging from EV 3 to EV 18 when you use the film speeded at ASA 100 (DIN 21).

For example, if the exposure meter needle is centered when you select aperture opening of f/5.6 with shutter speed of 1/125 second (the film speed dial is set at ASA 100), the brightness on the subject is supposed EV 12. If the brightness is at EV 12, you can use every one of seven different shutter speeds and get properly exposed pictures. If you change shutter speed

from 1/125 second to 1/250, one stop faster, the diaphragm has to be altered from f/5.6 to f/4, one stop larger aperture. Thus, you can use seven different shutter speeds ranging from 1/1000 second to 1/15 second (see the chart) when the EV is at 12.

What shutter speed you should use depends on the condition of subject. (Refer to SHUTTER SPEED DIAL at page 11.) The diaphragm opening should be also decided according to the purpose of your photography. (Refer to DEPTH OF FIELD at page 25.)

Exposure Meter Coupled Range Chart EV3~EV18 (ASA 100)

f \ EV	3	4	5	6	7	8	9	10	11	12	13	14	15	16	17	18
1.4	4	8	15	30	60	125	250	500	1000							
2(1.8)	2	4	8	15	30	60	125	250	500	1000						
2.8	1	2	4	8	15	30	60	125	250	500	1000					
4		1	2	4	8	15	30	60	125	250	500	1000				
5.6			1	2	4	8	15	30	60	125	250	500	1000			
8				1	2	4	8	15	30	60	125	250	500	1000		
11					1	2	4	8	15	30	60	125	250	500	1000	
16						1	2	4	8	15	30	60	125	250	500	1000

FILM LOADING

PETRI FTX accepts the standard 35mm cartridges containing 12, 20 or 36-exposure lengths of film. Avoid direct sunlight falling on the film

cartridge. Load the film in a shade, using your body with your back to the sun as protection if you have no other method.

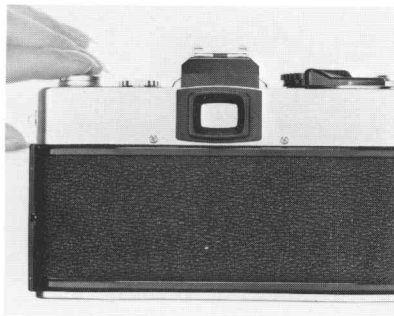

1. TO OPEN THE CAMERA BACK

Pull down the lever with your thumbnail and open the camera back. At the same time, the exposure counter automatically returns to "S" (which means "Start") position.

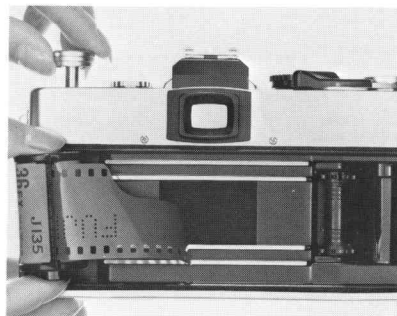

2. TO PULL OUT THE KNOB

Pull out the film rewind knob on top of the camera. This is to allow the film cassette to be put into the cassette chamber.

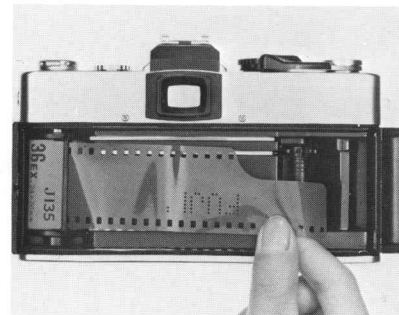

3. FILM LOADING

Slip the film end into any slit on the take-up spool and slide it down toward the bottom of the camera body, and check that the film perforation is properly engaged with the tooth of camera sprocket.

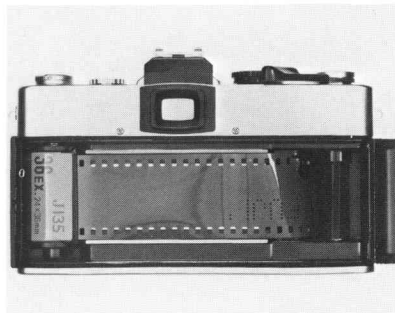

4. TO ADVANCE THE FILM

Advance the film advance lever a little and see that the film is fastened round the take-up spool, before closing the camera back.

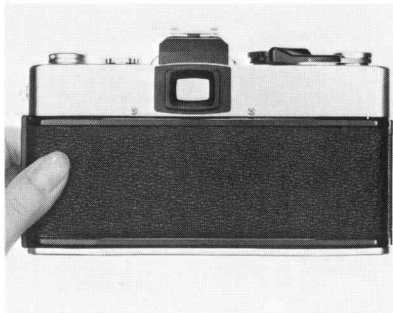

5. TO CLOSE THE CAMERA BACK

The camera back will be locked with a snap by a slight pressure.

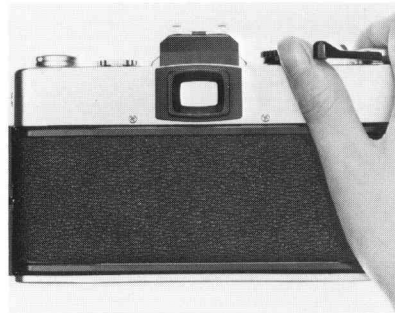

6. TO RELEASE THE SHUTTER AND ADVANCE THE FILM

Repeat this action twice, and you are ready to take your first picture.

NOTE: In case the film rewind knob does not turn counterclockwise by advancing the film advance lever, it shows that the film is not properly transported. Open the camera back and check the take-up spool.

FILM UNLOADING

After the entire length of film in the cartridge has been exposed, it must be

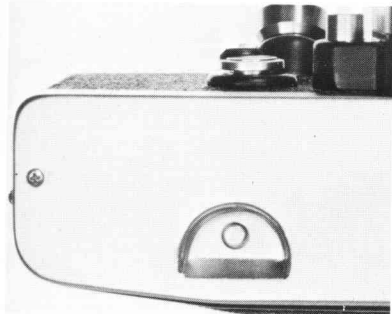

1. TO REWIND THE FILM

Depress the film rewind button located on bottom of the camera body. Raise the film rewind crank and turn it in the direction indicated by the arrow. You will feel

removed into the film cartridge so it can be removed from the camera.

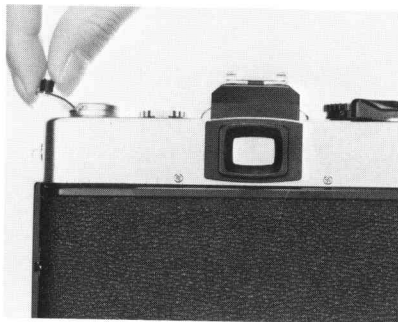

a little tension on the crank while the film is being rewound. When the tension stops, you know that the rewinding is complete.

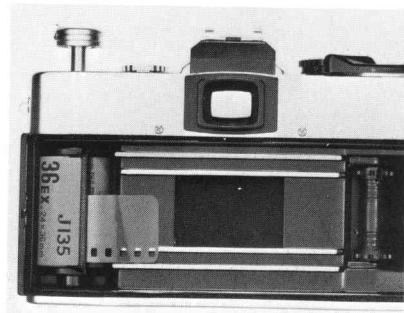

2. TO REMOVE THE CARTRIDGE

Pull out the film rewind knob and remove the film cartridge. Avoid direct sunlight when removing the film cartridge from the camera. Also, the camera lens should face downward while the cartridge is being removed so as to prevent it from dropping out.



HOW TO HOLD YOUR PETRI FTX CAMERA

The format of your picture is determined by the position in which you hold the camera. Holding the widest part in a horizontal position will result in a horizontal format. Holding the widest part in a vertical position will result in a vertical format. Blurring in a picture often is caused by camera shake at the moment of exposure. Practice holding the camera and releasing the shutter so you can take pictures without jarring or shaking it.

Use the following three simple rules for taking a picture to avoid camera movement:

1. Before releasing the shutter, take a deep breath and hold it until after the picture has been taken.
2. While taking the picture, hold the camera firmly with both hands and press the back against your face and forehead as firmly as possible.
3. Squeeze the shutter release button, do not prod or tap it. Practice squeezing until you can release the shutter without the slightest quiver.





HOW TO INTERCHANGE THE LENS

Petri FTX has a standard 55mm lens which features a screw mount and is most suitable for taking general-purpose pictures. It accepts a variety of interchangeable lenses from wideangle to telephoto and the built-in CdS exposure meter is geared to the interchangeable lenses.

To remove the lens, turn the lens in a counterclockwise direction until it can be removed.

To insert another lens, turn the lens in a clockwise direction until the lens is secured in position.

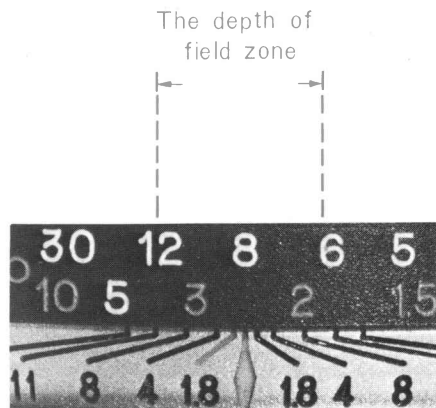

DEPTH OF FIELD

A lens that can be focused lets you accentuate the important image in a picture, while it can de-emphasize irrelevant objects in front of and behind the main subject by throwing them out of focus. This involves what is known as "Depth of Field". The smaller the aperture is the more the depth-of-field increases.

HOW TO READ THE DEPTH OF FIELD

The scale is engraved on the lens barrel of your camera and indicated in black lines spreading out both sides of the index marker at the center. Simply focus the lens in the normal way, and each pair of black lines which points to the diaphragm scale indicates the depth-of-field zone corresponding to the diaphragm you set. For example, the depth-of-field zone for the standard 55mm lens is indicated as follows: When the focusing distance is 8 feet and the f/11 is selected, one of black lines at f/11 points to 6 feet, the nearest point still in focus, and the other points to approximately 12 feet on the other side, being the furthest distance in focus.

DEPTH OF FIELD TABLE

(PETRI 55mm f/1.4 & f/1.8)

F NO. feet	1.4	1.8	2	2.8	4	5.6	8	11	16
2	1.98	1.98	1.98	1.97	1.95	1.93	1.91	1.87	1.82
	2.02	2.02	2.03	2.04	2.05	2.07	2.10	2.15	2.22
2.5	2.47	2.46	2.46	2.45	2.42	2.39	2.35	2.30	2.22
	2.53	2.54	2.54	2.56	2.58	2.62	2.67	2.74	2.86
3	2.96	2.95	2.94	2.92	2.89	2.85	2.79	2.71	2.60
	3.04	3.05	3.06	3.08	3.12	3.17	3.25	3.36	3.55
4	3.93	3.91	3.90	3.86	3.80	3.73	3.62	3.50	3.31
	4.07	4.10	4.11	4.15	4.22	4.32	4.47	4.67	5.06
5	4.89	4.86	4.84	4.78	4.69	4.58	4.42	4.23	3.96
	5.12	5.15	5.17	5.24	5.35	5.51	5.76	6.11	6.79
6	5.84	5.79	5.77	5.68	5.56	5.40	5.18	4.92	4.55
	6.17	6.22	6.25	6.35	6.52	6.75	7.14	7.68	8.80
8	7.71	7.63	7.59	7.44	7.23	6.96	6.59	6.18	5.60
	8.31	8.40	8.45	8.65	8.96	9.41	10.18	11.33	13.98
12	11.36	11.19	11.10	10.78	10.33	9.78	9.07	8.31	7.29
	12.72	12.94	13.06	13.53	13.31	15.51	17.73	21.61	33.97
30	26.25	25.35	24.92	23.33	21.31	19.09	16.52	14.14	11.40
	35.00	36.75	37.69	41.99	50.68	69.96	163.07	∞	∞
∞	208.77	162.38	146.14	104.38	73.07	52.19	36.53	26.57	18.27
	∞	∞	∞	∞	∞	∞	∞	∞	∞

The figures corresponding to 8 feet and f/11 are shown as 6.18 and 11.33, that is 6.18 feet, the nearest point in focus, and 11.33 feet, the furthest distance in focus.

F NO Meter	1.4	1.8	2	2.8	4	5.6	8	11	16
0.6	0.59	0.59	0.59	0.59	0.59	0.58	0.57	0.56	0.55
	0.61	0.61	0.61	0.61	0.62	0.62	0.63	0.64	0.66
0.7	0.69	0.69	0.69	0.69	0.68	0.67	0.66	0.65	0.63
	0.71	0.71	0.71	0.71	0.72	0.73	0.74	0.76	0.79
0.8	0.79	0.79	0.79	0.78	0.77	0.76	0.75	0.73	0.71
	0.81	0.81	0.81	0.82	0.83	0.84	0.86	0.88	0.92
1.0	0.99	0.98	0.98	0.97	0.96	0.94	0.92	0.90	0.86
	1.02	1.02	1.02	1.03	1.04	1.06	1.09	1.13	1.20
1.2	1.18	1.17	1.17	1.16	1.14	1.12	1.09	1.05	1.00
	1.22	1.23	1.23	1.24	1.26	1.29	1.34	1.40	1.51
1.5	1.47	1.46	1.45	1.43	1.41	1.38	1.33	1.27	1.19
	1.53	1.55	1.55	1.57	1.60	1.65	1.72	1.83	2.02
2	1.94	1.92	1.91	1.88	1.84	1.78	1.70	1.61	1.48
	2.06	2.08	2.09	2.13	2.19	2.28	2.42	2.63	3.07
3	2.87	2.83	2.81	2.75	2.65	2.53	2.37	2.20	1.96
	3.15	3.19	3.21	3.31	3.46	3.68	4.08	4.71	6.36
5	4.64	4.55	4.50	4.33	4.09	3.81	3.46	3.10	2.65
	5.42	5.55	5.62	5.92	6.43	7.25	8.99	12.83	44.59
10	8.65	8.33	8.18	7.62	6.91	6.15	5.28	4.49	3.59
	11.85	12.51	12.87	14.55	18.07	26.67	93.40	∞	∞
∞	63.63	49.49	44.54	31.82	22.27	15.91	11.14	8.10	5.57
	∞	∞	∞	∞	∞	∞	∞	∞	∞

FLASH PHOTOGRAPHY

When the exposure meter needle in the viewfinder stays below the circle (see page 17) and even a larger aperture opening and slower shutter speed can never make it come up into the circle it shows that the lighting condition is too poor and that you must switch to flash photography. Photography with flash not only extends your picture possibilities greatly but adds excitement and drama to your pictures. The use of flash equipment with your camera is relatively simple because it has built-in synchronization. It is equipped with X synchronization. Therefore, both electronic flash and ordinary single-exposure flashbulbs can be used.



Petri FTX is equipped with both a "hot shoe" contact for cordless unit and a standard PC terminal for one that has a cord. If you use a cordless unit, merely slip the foot of the unit into the shoe on top of the camera body and it will automatically make contact with the shutter mechanism. If the

unit has a cord, simply plug the cord into the flash socket ⑮.

When using F class, M class and FP class flashbulbs, or an electronic flash unit, shutter speeds must be selected according to the table. (Speeds within the colored area are available.)

$\frac{1}{1000}$	$\frac{1}{500}$	$\frac{1}{250}$	$\frac{1}{125}$	$\frac{1}{60}$	$\frac{1}{30}$	$\frac{1}{15}$	$\frac{1}{8}$	$\frac{1}{4}$	$\frac{1}{2}$	1
FP Class Bulb					FP Class Bulb					
				F Class Bulb						
					M Class Bulb					
				Electronic Flash Unit						

EXPOSURE CONTROL IN FLASH PHOTOGRAPHY

In flash photography the exposure meter can not be used. The exposure depends on the shutter speed, the aperture opening, the film speed and the distance of the light from the subject, but if the shutter speed is constant and also the film speed is assumed to be constant, then the f/number required varies according to the lamp-to-subject distance. In another word, for any given shutter speed and film speed, the product of the aperture opening and the lamp-to-subject distance becomes a constant, and this constant is called the Guide Number. Thus, the f/number is calculated by the following formula:

$$\text{Guide Number} = \text{Distance} \times \text{f/number}$$

$$\text{f/number} = \frac{\text{Guide Number}}{\text{Distance}}$$

For example, in case a flashbulb of the FP class is used and the guide number corresponding to the ASA (or DIN) index and to the shutter speed selected is supposed to be 74, then the f/number, if the lamp-to-subject distance is 10 feet, will be about 8, because $74 \div 10 = 7.4 \approx 8$. No great accuracy is required in this calculation, and a quick mental division will give an f/number for any distance. In all cases, the nearest click-stop or 1/2 stop will be close enough for a practical work. The guide numbers are usually indicated on the packages of your flashbulbs or in the instruction manual of your strobo.

HOW TO USE THE BUILT-IN SELF-TIMER

Swing the self-timer lever in the direction indicated by the arrow as illustrated. Release the self-timer release button ⑩, and the frame will be exposed after a delay of approximately 9 seconds. The self-timer can be set at between positions (within the range of solid line) so as to shorten the release time and also be set either before or after advancing the film. All shutter speeds except B setting can be used with the self-timer.

The self-timer is usually used when the photographer wants to join a group which he is photographing. It is also useful for photomicrography or when using a long focal length lens. In all cases the use of a tripod is recommended.

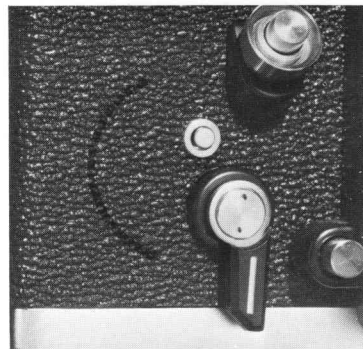

INFRARED PHOTOGRAPHY

When taking infra-red pictures, reset the focusing distance to the red line indicated by the aperture f/4 (or f/1.8) on the depth of field indicator ⑱.



MAINTENANCE AND CARE OF YOUR PETRI FTX

A few simple precautions, careful handling and immediate attention in case of trouble will prolong the life of your camera and keep it operating well indefinitely. Follow these simple rules:

1. When cleaning the outside of the camera, first use a soft brush and then a soft cloth.
2. Remove dust and sand that enter the camera while it is open immediately, using a camel-hair brush or a hand-blower.
3. Dust, fingerprints, water drops, etc., on the lens not only affect picture contrast but, if left for a long time, they will attack the surface.
4. Should your camera fall into water, immediate attention is imperative. Bring it to a repair shop at once. If it falls into salt water, rinse it thoroughly in fresh water and then deliver it to the repairman.
5. Your camera, when not in use, should be protected from damp and dust. Preferably in its case and, as an additional precaution, inserted into a polythene bag.
6. Be sure that your camera is not kept in abnormally high or low temperatures—normal room temperature is best.
7. Before storage, release the shutter and relieve a tension of every apparatus. When you store your camera for a prolonged period, remove a battery and avoid a risk of deterioration and corrosion.
8. Do not leave your camera without use for a long period. Your camera, as any other mechanical instrument, needs to be exercised regularly to keep it in good condition. Set the shutter release and fire, turn to a slow shutter speed and again set the shutter release and fire. Also, operate the self-timer. Examine the exposure meter for correct operation. Check film transport. Check the Pentaprism view-finder. These actions will keep the mechanism in good order, retaining the natural qualities of the lubricant—thus ensuring your camera is ready for an instant use when required.

FILTERS

Essential for first class photographs. Select the proper filters for your needs.

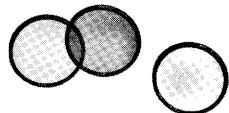

For Black & White Film:

FILTER TYPE	FILTER FACTOR	COLOR	PURPOSE
Y1	1.5X	Light Yellow	Landscapes, snow, clouds. Renders yellow and green lighter.
Y2	2 X	Medium Yellow	Gives stronger effect than Y1.
YA3	4 X	Orange	Haze distant views. Renders yellow and red lighter, blue darker, distant objects clearer.
R1	8 X	Red	Hazy distant views. Renders red lighter, blue and green darker. Gives stronger effect than orange filter.
PO0	2.5X	Green	Landscapes, snow, clouds. Renders green lighter. Red (complexion) and blue darker. Recommendable for portraiture.
PO1	4 X	Medium Green	Gives stronger effect than PO0.

For Color Film:

FILTER TYPE	FILTER FACTOR	COLOR	PURPOSE
UV	no increase	Clear	Absorbs excessive UV. Also suitable for black-and-white.
1A	no increase	Light Pink	To eliminate haze and for use at altitudes over 3,000 ft.
W4	1.5X	Medium Amber	Reduces excessive blueness of sky on a cloudy day.
C4	1.5X	Medium Blue	For early morning or evening shots.
C8	2 X	Dark Blue	Conversion filter for use when using "Daylight Type" color reversal film with white flash bulbs.
C12	2.5X	Dark Blue	Conversion filter for use when using "Daylight Type" color film with photoflood lamps.
85C	no increase	Dark Amber	Conversion for use when using "Artificial Light" film in daylight.
NDX4	4 X	Neutral Density	Neutral Density for sunny subjects. Can also be used for black-and-white.

ANGLE FINDER

A right-angle viewfinder specially designed to be used with the Extension Bellows or Tubes for convenient and easy photography.

LENS HOOD

Recommended for indoor and outdoor photography under all conditions to eliminate stray light that degrades the image. Particularly important for outdoor shots on the beach and other high-reflecting areas and for flash.

EYE CUP

Attaches to the eyepiece and permits the spectacle user to get close to the viewfinder without difficulty. Also recommended for unaided viewing and focusing without spectacles and for elimination of stray light.

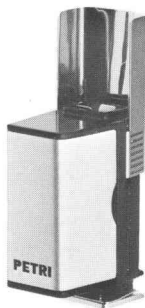
**FLASH GUN**

Solidly constructed, compact, battery-powered flashgun with a slide-up reflector and a bulb ejector. Powered by one W10 15-volt battery through a cordless shoe contact, and takes AG-type flashbulbs.

BRACKET

Collapsible L-shaped camera holder with hand grip, bounce-type universal accessory shoe on top and wrist strap. Adjustable for still and movie cameras.

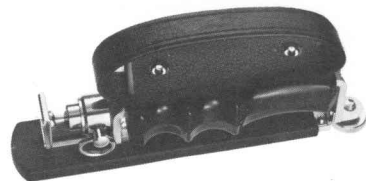
**CABLE RELEASES**

Metal-covered accessories that permit the shutter to be released without camera shake. Two types are available, both 12" long. One has the automatic stopper for time exposure, the other comes with a manual release stopper.