

120 SERIES
MEDIUM FORMAT CAMERAS
OPERATION INSTRUCTIONS

MODEL 120N, 120GN

STANDARD CAMERA WITHOUT BUILT-IN FLASH

MODEL 120FN, 120GFN

CAMERA WITH BUILT-IN FLASH

MODEL 120CFN, 120GCFN

**CAMERA WITH BUILT-IN FLASH
&
COLOR FILTER FUNCTION FOR BUILT-IN FLASH**

Table of Contents

	<u>Page</u>
1. Parts of the Camera	1
2. Film to Use	1
3. Setting Frame Size/Number of Frames per Roll of Film	1
4. Installation of Batteries (for 120FN, 120GFN and 120CFN, 120GCFN only)	2
5. Film Loading	2
6. Focusing	3
7. Choice of Aperture	4
8. Picture Taking	4
9. Use of "B" Exposure	4
10. Multi-Exposure Effect	5
11. Removal of Film	5
12. Use of Built-in Flash (for 120FN, 120GFN and 120CFN, 120GCFN only)	5
12.1 How to Use the Flash (for both 120FN, 120GFN & 120CFN, 120GCFN)	5
12.2 Selecting Color Filter for Flash (for 120CFN, 120GCFN only)	6
13. Some Simple Suggestions	6
14. Specifications	7
15. Optional Accessories – Color Filters & Special Effect Lenses	7
15.1. Color Filters	8
15.2. Soft Surround Lenses	8
15.3. Split-Image Lenses	8
15.4. Gradation Filters	8
15.5. Double Color Filters	8
15.6. 135 Film Adapter Kit FA135 – 120	9
15.7. Darkroom Bag DRB-01	9

OPERATION INSTRUCTIONS

1. Parts of the Camera

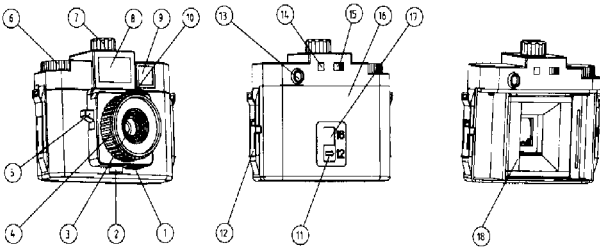

- | | |
|---|---|
| (1) "B" Exposure Switch | (10) Aperture Setting Knob |
| (2) Tripod Mounting Socket | (11) Frame Number Pointer |
| (3) Exposure Lens | (12) Back Cover Latch |
| (4) Focus Ring | (13) View Finder Eyepiece |
| (5) Shutter Release Button | (14) Flash Ready Lamp (for 120FN, 120GFN only) |
| (6) Film Advance Knob | (15) Flash On/Off Switch (for 120FN, 120GFN only) |
| (7) Flash Color Filter Selection Dial for 120CFN, 120GCFN only) | (16) Back Cover |
| (8) Built-In Flash (for 120FN, 120GFN & 120CFN, 120GCFN only) | (17) Frame Counter Window |
| (9) View Finder | (18) Frame Size Mask |

2. Film to Use

The camera can accommodate all 120 format films. The use of exposure speed ASA 100 films on sunny days and ASA 400 on cloudy days or indoor occasions is recommended.

3. Setting Frame Size/Number of Frames per Roll of Film

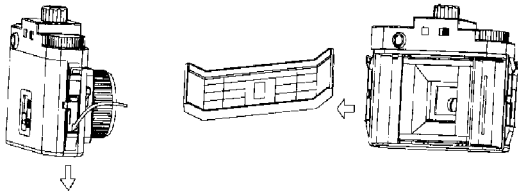

The camera is provided with two different Film Size Masks - one for 16 frames of 6 x 4.5 cm each per roll and the other 12 frames of 6 x 6 cm. There is the number "16" or "12" in one of the corners of the Film Size Masks for identification. Follow the steps below to set the frame size and frame number -

- (a) Push downward the Back Cover Latches on the two sides to unlatch and remove the Back Cover.
- (b) Remove the Frame Size Mask originally inside the camera and swap in the one for the desired number of frames per roll.
- (c) Slide the Frame Number Pointer on the Back Cover to point at the number of frames which matches that of the Frame Size Mask used, revealing the appropriate Frame Counter Window at the same time.
- (d) Re-install the Back Cover and latch it on the two sides.

4. Installation of Batteries (For 120FN, 120GFN Only)

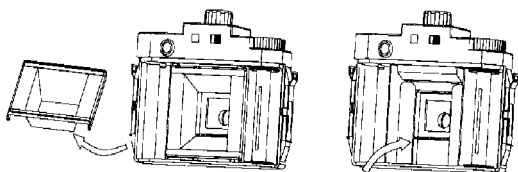

Two AA batteries are required for operating the Built-In Flash. Take following steps to install the batteries -

- (a) Push downward the Back Cover Latches on the two sides to unlatch and remove the Back Cover.
- (b) Remove the Frame Size Mask to expose the Battery Compartments on the two sides of the lens/shutter compartment.
- (c) Load an AA battery into each of the two compartments, aligning the polarity according to the indications inside the compartments.
- (d) Put back the Frame Size Mask and the Back Cover and then latch the Back Cover in place.

5. Film Loading

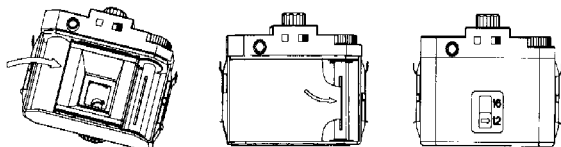

- (a) Push downward the Back Cover Latches on the two sides to unlatch and remove the Back Cover.

- (b) Break the seal of the film roll and hold it on the outside where the backing paper is.
- (c) The Film Compartment is on the left of the camera. Engage the hole on the top end of the film spool into the pin in the Film Compartment while sliding the film roll into the compartment. The tapered end of the film must be pointing towards the Take-Up Spool on the right side of the camera.
- (d) Pull out about 4 in. (10cm) of film while keeping the film roll inside the compartment with the thumb.
- (e) There is a long slot on the Take-Up Spool on the right side of the camera. Insert the tapered end of the film into this long slot and give the Film Advance Knob 2/3 turns in the direction of the arrow sign, carefully aligning the top and bottom edges of the film against the top and bottom edges of the inside of the camera.
- (f) Replace the Back Cover and latch it in place on the two sides.
- (g) Turn the Film Advance Knob in the direction of the arrow sign until the number "1" appears in the red Frame Counter Window.
- (h) The camera is now ready for use.

6. Focusing

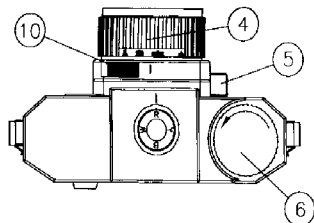

Although this camera is basically a fixed focus camera, it still offers four choices of object distances. There are four symbols on the Focus Ring to select the following object distances -

- (a) Symbol of One Person = 1m or 3.25 ft.
- (b) Symbol of Three Persons = 2m or 6.50 ft.
- (c) Symbol of Several Persons = 6m or 20.00 ft
- (d) Symbol of Mountains = 10m or 33.00 ft.

More precise setting for object distances can be achieved by setting the Focus Ring at positions in between two symbols.

7. Choice of Aperture

Two choices are available for selection as follows –

- (a) Sunny Symbol = $f/11$ for use on sunny days; and
- (b) Cloudy Symbol = $f/8$ for use on cloudy days.

8. Picture Taking

- (a) Set the aperture according to the weather/environmental conditions :-
 - Sunny symbol for sunny outdoor occasions; and
 - Flash/Cloudy symbol for cloudy outdoor or insufficiently lit-up indoor occasions.
- (b) Estimate the object distance and turn the Focus Ring to set the object distance accordingly.
- (c) Look through the View Finder and compose the picture. Then press down the Shutter Release Button slowly to capture the image.
- (d) Turn the Film Advance Knob slowly until the number for the next frame appears in the Frame Counter Window. The camera is now ready for taking the next picture.

9. Use of “B” Exposure

This function is for taking extended-exposure pictures at nighttime or indoors to give the picture a sense of motion. The steps to be taken are as follows -

- (a) Mount the camera on the top of a tripod. This is necessary to avoid unnecessary moving of the camera, which can occur even due to the breathing action of the photographer, during the extended exposure.
- (b) Set the “B” Exposure Switch to the “B” position.
- (c) Push down the Shutter Release Button to and keep it down for 1 to 5 minutes, as desired. Then, release the button to close the shutter to complete the picture taking cycle.
- (d) Set the “B” Exposure Switch back to the normal “N” position.

10. Multiple-Exposure Effect

As the film is advanced manually, this camera can help achieve special effects through multiple exposure by not advancing the film after a frame has been exposed. Each depression of the Shutter Release Button will bring about another exposure. This feature will provide more latitude for the photographer to try out his/her imagination.

To achieve multiple exposure is very easy - simply do NOT advance the film after a picture has been taken.

11. Removal of Film

Take following steps -

- (a) Turn the Film Advance Knob until no more number appears in the Frame Counter Window, which indicates that the whole film roll has been transferred and wound onto the originally empty Take-Up Spool.
- (b) Push downward the Back Cover Latches on the two sides of the camera to unlatch and remove the Back Cover.
- (c) Remove the film roll, which is now wound onto the originally empty Take-Up Spool, from the camera. Turn the spool of the roll to tighten up the roll and then use a piece of cellophane tape to tape the open-end of the roll firmly in position. The film roll can now be sent for processing.
- (d) Transfer the now empty spool on the left to the Take-Up Spool Compartment on the right for use next time as the Take-Up Spool.

12. Use of Built-In Flash (For 120FN, 120GFN and 120CFN, 120GCFN Only)

There are two models of cameras in the series with a built-in flash, namely a Model 120FN, 120GFN which has only a standard flash function and a Model 120CFN, 120GCFN where there are selectable color filters for the built-in flash.

12.1. How to Use the Flash (For Both 120FN, 120GFN and 120CFN, 120GCFN)

The following descriptions for using the built-in flash are applicable to both models 120FN, 120GFN and 120CFN, 120GCFN -

- (a) Make sure the exposure setting is in the position with the lightning symbol “”.
- (b) Slide the Flash On/Off Switch to the “On” position. The flash will begin to re-charge and a low whistling can be heard.

- (c) The Flash Ready Lamp should come on in a few seconds, signifying that the flash is now ready to fire.

If the Flash Ready Lamp does not come on within 30 seconds, it means the batteries have pretty much run out and should be replaced.

- (d) The flash should be turned off to conserve battery power if it is not to be used.

12.2. Selecting Color Filter for Flash (For 120CFN, 120GCFN Only)

There are three color filters, namely red, blue and yellow available for changing the color temperature of the originally 5600K white daylight emitted by the flash.

(a) **Effects of Filtering Flash Light**

The effects of putting color filters over the built-in flash when using the flash function are similar to those of putting color filters over the lens without the use of flash. Please refer to Paragraph 15.1 below for a description on the effects of the various color filters.

(b) **Selecting Color Filter for Flash**

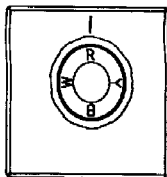

There is the Flash Color Filter Selection Dial on the top of the camera. There are the letters W, R, B and Y engraved around the edge on the top surface of the dial. They stand for the following -

- W = without color filter
R = red color filter
B = blue color filter
Y = yellow color filter

To choose a filter (or not filter), simply turn the dial to position the letter for the color desired against the white line in the front of the camera just below the knob.

13. Some Simple Suggestions

- (a) Always check to see that the lens cap has been removed before taking a picture.

- (b) Always take pictures with the sun behind the camera.
- (c) Always Hold the camera steadily and firmly against one's face.
- (d) Always press down the Shutter Release Button gently to avoid jerking.
- (e) Always advance the film until the next Frame Counter number appears in the Frame Counter Window after a picture is taken.
- (f) Always load or remove films in a dark place.
- (g) Always use the flash when taking pictures in shades or an insufficiently lit up room.
- (h) Never take pictures with an object distance of less than 3.25ft.
- (i) Always clean the lens only with a piece of soft and smooth cloth.

14. Specifications

Type	120 type with (120FN & 120CFN) or without built-in flash (120N,120GN)
Lens	Optical lens, f/8 60mm
Shutter	Leaf shutter, speed 1/100sec.
Film to be Used	120 format color or black/white film of ASA 100 /ISO 21 or ASA 400/ISO 27 speed
View Finder	Eye level, direct view finder
Focusing	Adjustable
G.N. of Flash	12 (ASA 100/DIN 21.m) (for 120FN, 120GFN & 120CFN 120GCFN only)
Power for Flash	Two AA size penlight batteries (for 120FN,120GFN & 120CFN, 120GCFN only)
Dimensions	140 x 102 x 76 mm
Weight	200g without batteries
Accessories Included	1 Strap, 2 Frame Size Masks and 1 Take-Up Spool

15. Optional Accessories - Lens/Filter Holder for Lens/Filter of Special Effects

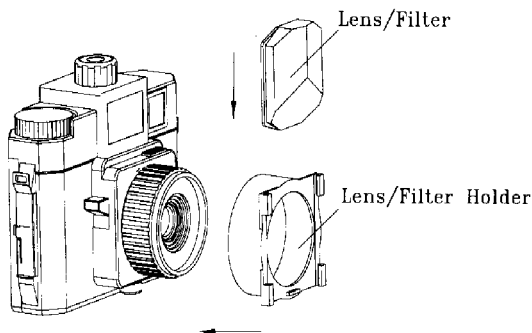

There is a Lens/Filter Holder available as an optional accessory. Lenses/filters for different effects, also available as optional accessories, can be inserted into the Lens/Filter Holder. The Lens/Filter Holder is then installed by being slid over the bezel of the lens of the camera.

There are five types of lenses/filters available as optional accessories. They are as follows –

15.1. Color Filters - Color Filters are for altering the color temperatures of the object and the background to enhance the artistic effect of the picture. There are four different filters available to bring about the following effects –

Blue To raise the color temperature e.g. to simulate beautiful moon light when taking picture in the country side.

Red To reduce the absorption of blue and green lights.

Yellow To reduce the absorption of blue light to correct the sensitivity of full color films to lights in the blue to purple range.

Light Orange To lower the color temperature to remove the cold tone in flash light to accomplish a warmer light source.

15.2. Soft Surround Lenses - These lenses have a clear circular area in the middle and the remaining areas frosted. They are for standing out the object to be taken to make the theme of the picture more prominent. Four colors - blue, red, orange and grey are available for selection.

15.3. Split-Image Lenses - There are three types available as follows –

Quintuple Image = 5 images will result, just like five exposures.

Horizontal Triple Images = 3 images lined up horizontally.

Triangular Triple Images = 3 images in the three vertices of a triangle.

15.4. Gradation Filters - This is a set of 4 filters. Half of each filter is colored and the other half clear. The colored half of the filter is a gradation of the color from full intensity to total clearness when moving from the edge towards the intersection with the clear half. These filters can be used to emphasize the color of the object to be photographed, stand out a blue sky or suppress overly bright exposures. The four colors available are red, yellow, blue and grey.

15.5. Double Color Filters - These are filters with one half in one color and the other half another. They are good for generating special color effects. There are six filters in a set in the color combinations of red/yellow, red/blue, red/grey, yellow/blue, yellow/grey and blue/grey respectively.

- 15.6. 135 Film Adapter Kit FA135-120 - The Adapter Kit includes a 135 Adapter Frame and a 135 Back Cover. It is for adapting the camera to use 135 format films.
- 15.7. Darkroom Bag DRB-01 - For putting the camera inside for changing films.

