



This manual is for reference and historical purposes, all rights reserved.

This page is copyright© by M. Butkus, NJ.

This page may not be sold or distributed without the expressed permission of the producer

I have no connection with any camera company

On-line camera manual library

This is the full text and images from the manual. This may take 3 full minutes for the PDF file to download.

If you find this manual useful, how about a donation of \$3 to: M. Butkus, 29 Lake Ave., High Bridge, NJ 08829-1701 and send your e-mail address so I can thank you. Most other places would charge you \$7.50 for a electronic copy or \$18.00 for a hard to read Xerox copy.

This will allow me to continue to buy new manuals and pay their shipping costs.

It'll make you feel better, won't it?

**If you use Pay Pal or wish to use your credit card,
click on the secure site on my main page.**

Minolta SUPER 'A'



INSTRUCTIONS FOR USING

Minolta Super 'A' is YOUR faithful companion.

The very best results from your Super A will soon prove you that you were quite wise in choosing the Minolta Super A from among a large variety of cameras.

Minolta cameras are being exported from Japan in the biggest quantity and have innumerable fans the world over. This bespeaks the surpassing efficiency and the most reasonable price of Minolta Cameras. The Minolta Super A, as well as the many other Minolta Products, are produced under the most exacting standards of quality control and strict tests.

We believe that the Super A will surely meet your demands in every respect.

Now, let us explain how to use YOUR Minolta Super A.

Focusing Lever. (The push button in the center is for interchange of lenses.)

Depth of Field Scale for 50 mm Standard Lens. (Distance indicator dot in the center of the scale is common for standard and interchangeable lenses.)

Illuminating Window for Bright Frame.

Viewfinder Window.

Rapid Rewind Crank.

Click-stop Shutter Speed Dial.

Accessory Shoe.

Film advance and Shutter-cock Lever.

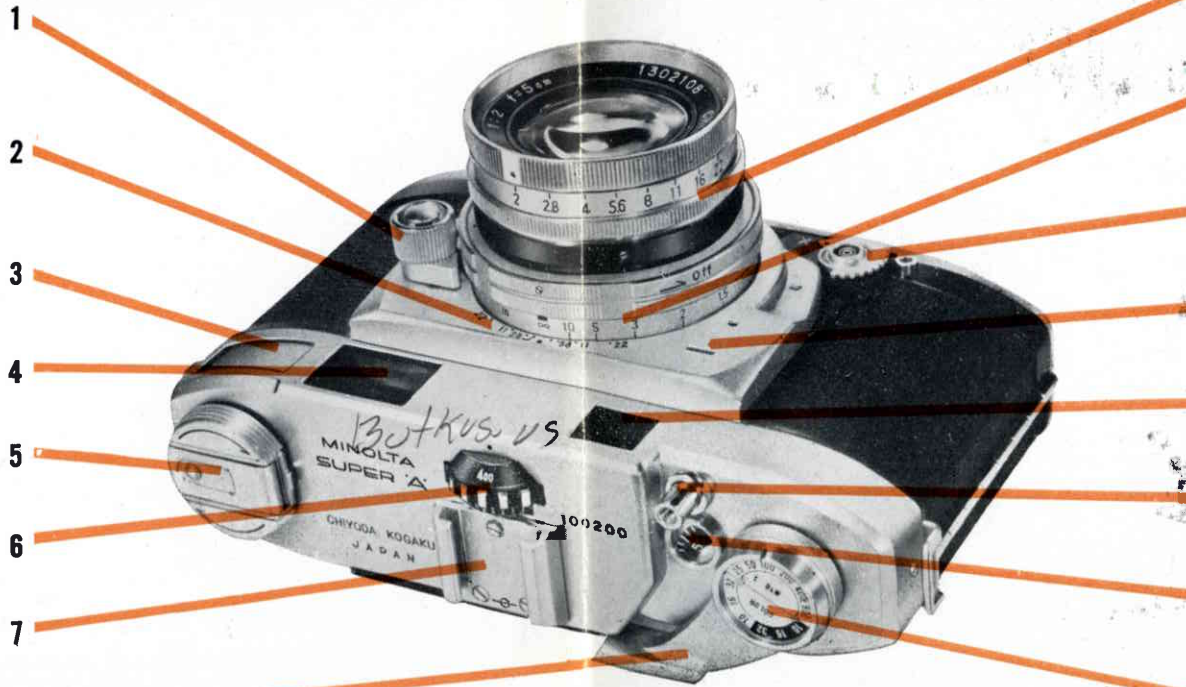

9 Click-stop Diaphragm Ring.

10 Distance Scale common for Standard and Interchangeable Lenses.

11 Synchro Selector and Synchronizer Connection.

12 Red Warning Signal.

13 Rangefinder Window.

14 Shutter Release Button.

15 Fully Automatic Film Counter.

16 Film Speed Indicator.

Rangefinder-Viewfinder Eyepiece common for 50mm and 35 mm Lenses.

Neck Strap Attachment.

Rewind Shaft.

Film Cartridge Chamber.

Back Locking Tab.

Tripod Mount.

17

18

19

20

21

22

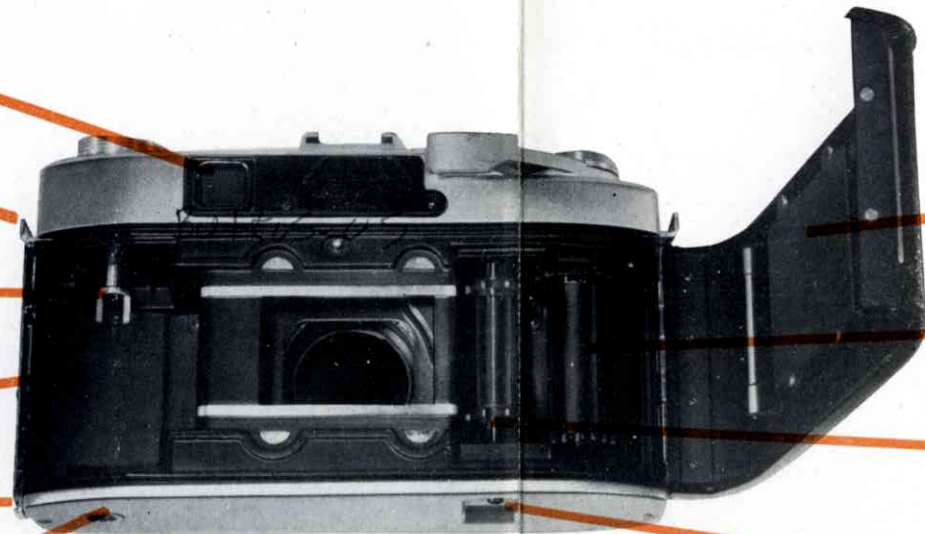

23

24

25

26

Pressure Plate. (Depth of field indicator for interchangeable lenses on back of the camera.)

Film Winding Spool.

Film Winding Sprocket.

Rewind (Sprocket) Release Button.

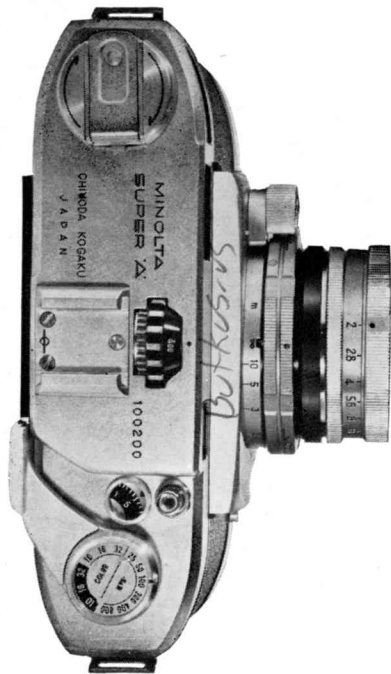

CONTENTS

	Page
Handling the Camera - - - - -	3
Focusing and Composing - - -	3
Film advance and Shutter cocking -	4
Shutter speed and Diaphragm settings - - - - -	4
To Load Film - - - - -	5
To Take Pictures - - - - -	7
To Remove the Film - - - - -	8
For Flash Operation - - - - -	9
Relative Diaphragm Openings to Shutter Speeds - - - - -	10
Depth of Field - - - - -	11
How to Read off the Depth of Field -	13
Interchange of Lenses - - - - -	15
Minolta's Interchangeable Lenses - -	16
Minolta's Accessories - - - - -	19

Focusing and Composing

While sighting through the finder eyepiece (17) turn the lens barrel by means of the focusing lever (1) until the pink image in the center of the finder is exactly superimposed over the full image. The red dot in the center of the depth of field scale (2) will then point to the number of feet (meter) on the distance scale indicating the subject-to-camera distance. The "Bright Frame" in the finder is the composing line for taking with 50mm standard lens. It remains clearly visible even under poor light and the permanent position

Out of focus



In focus



of the frame, even though you may move your eyes, will greatly diminish the possibility of your chopping off heads or other subject matter composed on the extreme edges of the finder.

When using a 35mm wide angle lens, the full range of the finder will be taken in the picture, there is no fear of "chopping off heads" or not taking portion of the picture if you look through the finder at the proper angle so that the frame comes to the correct position, as illustrated in above picture.

Film Advance and Shutter Cocking

Move the film advance lever (8) to your right until it stops. This can be done in one long stroke or several short ones. This moves the film to the next exposure and also cocks the shutter which can be released by pressing the shutter release button (14).

The winding of the lever also operates the film counter (15) which registers the number of exposed film up to 36 exposures and automatically returns to the start position when the camera back is opened.

Shutter Speed and Diaphragm Settings

The shutter speed can be selected by turning the shutter speed dial (6) so that the desired number clicks into position opposite the red dot. The markings are B, 1, 2, 5, 10 and up to 400. B means Bulb, and the shutter will stay open at this setting as long as the shutter release button is depressed, 1, 2, 5 400 mean 1 second, $\frac{1}{2}$, $\frac{1}{5}$ $\frac{1}{400}$ th second respectively.

N. B. When turning from 200 to 400 it is advisable to do so before shutter is cocked.

The diaphragm setting is done by turning the diaphragm ring (9) until the desired f stop number clicks into position opposite the dot.

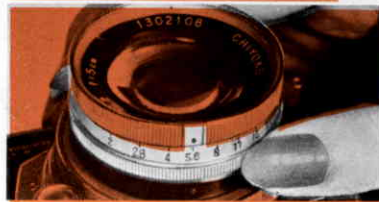

To Load Film

- 1** Pull out the back locking tab (21), open the camera back.
- 2** Pull the rewind knob (5) out as far as it will go and place a film cartridge in the chamber (20). Note that the spool on one end of the cartridge protrudes much further than on the other end. This protruding end must be pointing towards the bottom plate of the camera.
- 3** Insert the end of the film into the groove of the film winding spool (24). It is necessary to insure that the film is caught between the inner and outer flanges of the film winding spool, as illustrated.

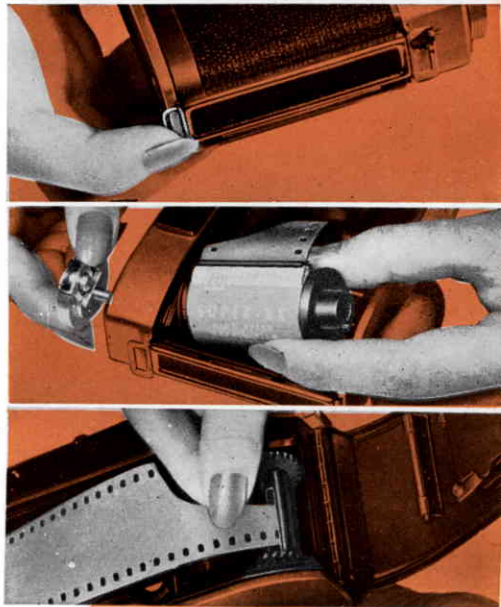

Film Cartridge

Film Winding Spool

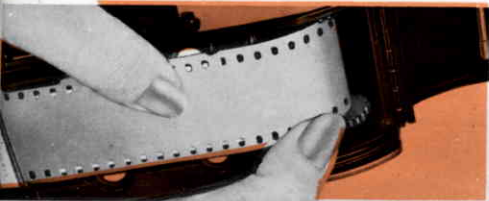
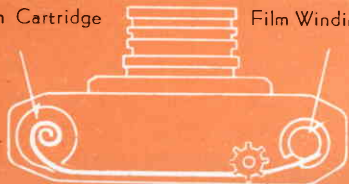

- 4 Turn the winding spool by means of the knurled edge to take up the slack on the film. Move the film advance lever (8) a few short strokes to be sure that perforations in the film mesh with the teeth of the film winding sprocket (25). If they do, close the back cover, then it will be automatically locked.
- 5 Move the film advance lever as far as it will go and release the shutter. Repeat this three times, you will find the film counter (15) automatically advances.
- 6 Turn the film speed indicator dial (16) until the number opposite the cut on the outer ring is the same as the ASA guide number of the film that you have loaded.

To Take Pictures



- Set the shutter speed dial (6) and the diaphragm ring (9) as previously instructed, to the required number.
- Move the film advance lever until it stops, and the number ① appears opposite the red ▼ in the film counter, indicating that the film is wound to the first frame. At this time the warning signal turns to red which shows you the film winding and the shutter cocking are completed.
- Looking through the finder (17) move the focusing lever until the two images coincide indicating correct focus.
- Keeping the camera as steady as you can, press the shutter release (14) firmly but smoothly to trip the shutter. To use a selftimer or a cable release, screw them in the socket of the shutter release button. If you press the shutter release too strongly, you will move the camera during the exposure and not get the sharp picture you had intended. When using shutter speeds slower than $\frac{1}{25}$ sec., the camera should be placed on a tripod or held firmly against some stable object to keep it from moving.

After all the film has been exposed it is necessary to re-wind it into the film cartridge for removal from the camera. This is quickly and easily accomplished.

- Push in the rewind release button (26) located on the bottom plate of the camera. You will note that the button remains in the "pushed in" position.
- Raise up the rewind crank (5) and wind it in the direction indicated by the arrow. Continue to wind until you feel the film leave the film winding spool, you will recognize this by the sudden release of tension in the rewinding. Then, wind two or three more turns in order to get all the film completely into the film cartridge.

Note: Should the rewind release button inadvertently pop out while rewinding, move the film advance lever a little, then push the button in again and continue as before.

- It is now possible to open the back and remove the film cartridge for processing. After the film is removed the rewind release button will pop out when the film advance lever is moved.

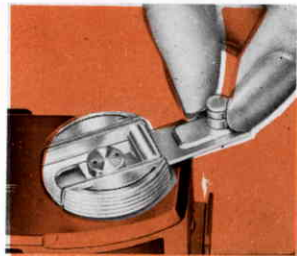
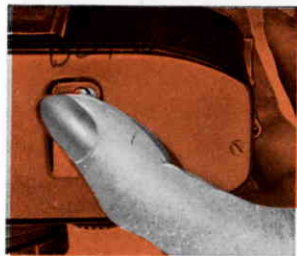

To Remove the Film

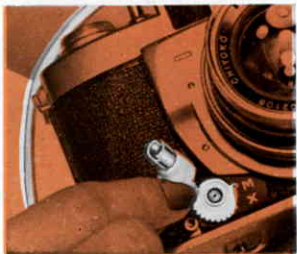
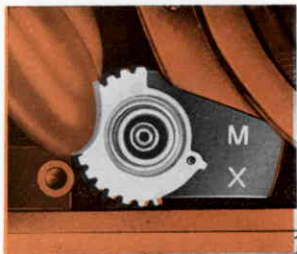

Your Minolta Super A is internally synchronized for use with electronic flash or with flash bulbs at all shutter speeds. However, the proper settings must first be made.

- For electronic flash use, set the synchro selector (11) so that the dot points to red "X".









Note : On this setting, class F (gas filled) flash bulbs can also be used at the shutter speed of $\frac{1}{30}$ sec. or slower.

- For class M (foil filled) flash bulbs, set the selector at yellow "M".

The flash unit may be used by sliding it into the accessory shoe or held by hand away from the camera. Attach the plug of the flash cord to the synchronizer connection in the center of the synchro selector.

The Diaphragm Opening of a Lens controls the volume of Light that reaches the film in a given period of exposure. The Dial Markings indicate this volume of Light (see the diagram). Each Stop opening indicated on the dial by the numbers 2 to 22 reduces the amount of light passing through the lens by $\frac{1}{2}$, or conversely, opening the lens from one mark to the next from the number 22 to 2 doubles the amount of light. The shutter controls the amount of light by the length of time it remains open i. e. 1 second, $\frac{1}{2}$ second, $\frac{1}{5}$ sec. etc. Now, suppose you have determined by an exposure meter reading or other means that the correct exposure for your film under certain light conditions is $\frac{1}{200}$ second at f 8, and you want to use a faster shutter speed because your subject is in motion. A shutter speed of $\frac{1}{100}$ second cuts the exposure in half, so you must open the lens one stop to f 5.6 which will allow twice as much light to pass through and the amount of exposure will be the same as before.

Conversely, if you need to stop down the lens for greater depth of field (see explanation of Depth of Field next) and you select 16 as the correct stop opening you have reduced the amount of light to $\frac{1}{4}$. Then you must give the film an exposure 4 times as long or $\frac{1}{12}$ second, in this case you select the nearest shutter speed which is $\frac{1}{10}$ second.

F. No.	2	2.8	4	5.6	8	11	16	22
Volume of Light								
	1	$\frac{1}{2}$	$\frac{1}{4}$	$\frac{1}{8}$	$\frac{1}{16}$	$\frac{1}{32}$	$\frac{1}{64}$	$\frac{1}{128}$

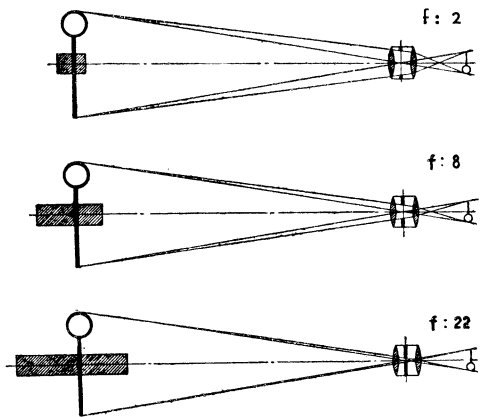

The depth of field of a lens is the range of distance within which all objects are in relatively sharp focus when the lens is set for a given distance. This range varies with the diaphragm opening, being greatest when the lens is stopped down and least when it is open full (see diagram). The range also varies with the distance for which the lens is set being least at close distances and greatest at farther distances up to a point where it takes in everything beyond an intermediate distance to infinity, which is indicated by ∞ on the distance scale.



Little depth of field



Great depth of field

How to Read off the Depth of Field

For Standard 50mm Lenses

In this case, the depth of field can be directly read off on the depth of field scale (2).

After focusing, the subject-to-camera distance is indicated by the red dot on the depth of field scale, and the subject at this distance, is in the sharpest focus. The numbers on both sides of the red dot mean f stops and the depth of field i.e. near and far limits of sharp focus is indicated opposite them corresponding with f stop chosen.

For Example :

Focused at 5 meters with f 5.6, the depth of field is from about 4 to 8 meters; or with f 11 in this case, the depth of field extends from about 3 to 10 meters.

Note : In case of f 4, f 8 or f 16, which are not marked on the scale, remember that f 4 is positioned between f 2.8 and f 5.6, similarly f 8 is between f 5.6 and f 11, f 16 between f 11 and f 22, then read the depth of field.

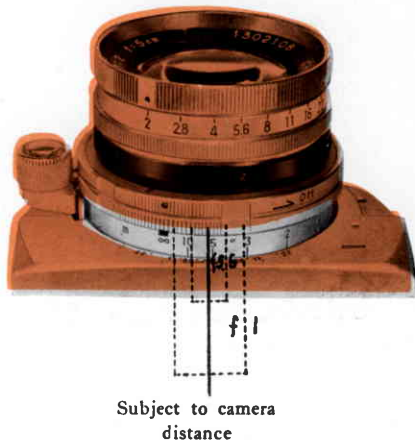

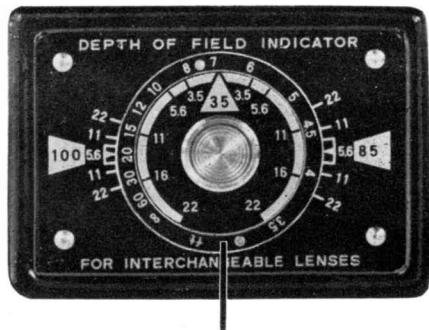

Distance ring

For Interchangeable Lenses

The depth of field can be worked out by the indicator on the back of the camera.

For 35mm Lens :

The mark \triangle_{35} on the dial indicates the focused distance and the numbers arranged in pairs on both sides of the mark mean f stops.

If you have focused the lens at 7 feet which has been indicated on the distance scale, turn the distance ring on the indicator right or left until "7" on it comes opposite the mark \triangle_{35} , then the depth of field corresponding with the distance (7 feet) and f stop chosen can be read off on the scale ; for instance focused 7 feet with f 11, the depth of field is from about 4.5 to 15 feet.

For 85mm or 100mm Lens :

The method is the same as in the case of 35mm lens. The scale for 85mm lens is on the right and for 100mm lens on the left.

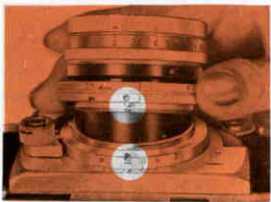

Any of the interchangeable lens for the Minolta Super A can be removed or attached in the same manner as follows.

To Remove

- Adjust the distance scale to infinity (∞).
- While pushing the button located in the focusing knob (1), turn the ring on which "on" and "off" are engraved in the direction of "off" until it stops. The lens can now be removed.

To Attach

- Adjust the distance scale to infinity (∞).
- Adjust the two red dots on the lens barrel till they coincide.
- Attach the lens carefully on the bayonet lens mount of the camera, making sure red dots of lens barrel are opposite the red dot of the depth of field scale. This allows the projection on the lens barrel to fit into the receiver on the body lens mount. Then pushing the button in the focusing knob, turn the "on and off" ring in the direction of "on" with slight pressure until it stops.
- To secure the lens firmly on to the mount, turn the "on and off" ring slightly in the direction of "off" without pressing the button this time, then the button will pop out to the original position (probably you will hear a click). This allows the focusing lever to be moved; in other words, when you can move the lever, it proves the lens to be secured.



Interchangeable "**Rokkor**" lenses for the Minolta Super A are specially designed for the camera and are available to suit all of your various needs. They are coupled exactly with the rangefinder of the Minolta Super A and will give the great advantage of "versatility" to your Super A.

All of them have the superior capacity to make sharp black and white and brilliant color pictures. They also have hard coated surfaces and are equipped with click stop equidistant diaphragms.

Rokkor 35mm f 3.5 4 element

Especially suitable for snapshots or interior photography. This is due to the wider angle of view and the greater depth of field in comparison with standard 50mm lenses.



Angle of view: 64°

Diaphragm openings: from f 3.5 to f 22

Nearest focusing distance: 3.3 ft.

A special finder is not required as the finder of the Super A is sufficient.



Standard Lenses

Rokkor 50mm f 2

7 element

Rokkor 50mm f 2.8

5 element



Widely used for all purposes.

Angle of view: 46°

Diaphragm openings: from f 2 (t 2.8) to f 22

Nearest focusing distance: . 3.3 ft.



Rokkor 85mm f 2.8 5 element

Excellent for close-up portraits or distant scenes. Image taken is 1.7 times that of standard 50mm lens.

Angle of view : 29°

Diaphragm openings :
from f 2.8 to f 22

Nearest focusing distance :
5 ft.

Individual "Bright Frame View-finder" with the parallax correction dial is provided.

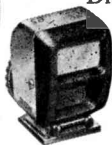

Rokkor 100mm f 3.8 5 element

Most useful for taking long distant subjects, sports shots or animal life. Image taken is 2 times that of standard 50mm lens.

Angle of view : 24°

Diaphragm openings :
from f 3.8 to f 22

Nearest focusing distance :
7 ft.

Individual "Bright Frame View-finder" with the parallax correction dial is provided.



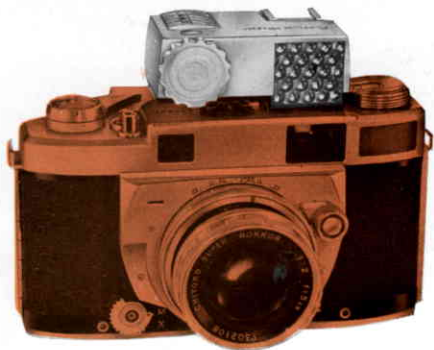

The two separate windows on the meter show the correct shutter speed and f stop number. When the adjusting knob is turned, the various combinations of shutter speed and f stop number appear; one of them can be chosen according to whether moving subjects are to be taken or greater depth of field is required.

Minolta Meter

The Minolta Super A can take our exclusive exposure meter, the Minolta Meter which does away with any guess work or calculations and assures correct exposure. The meter, coupled to the shutter speed dial of the camera, only requires the operator to adjust the diaphragm scale of the camera as indicated by the meter.



The meter is usable under any lighting conditions even poor light as the amplifier is attachable to the meter for 4 times increase of sensibility.

The meter can also be operated independently without attaching it to the camera.

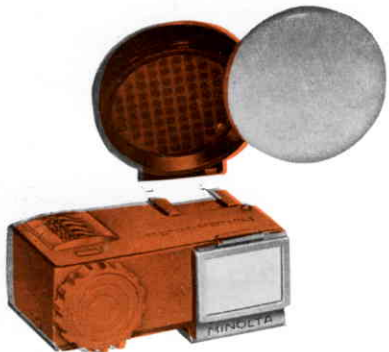

Incident Light Attachments are provided for the meter and the amplifier for measuring light by the "incident light method" which enables an exact measurement where the ordinary "reflected light method" may be slightly inaccurate.



Minolta Junior B.C. Flash

A small pocket-sized unit which operates on the B. C. principle. A 22.5 V dry battery and a condenser (capacitor) can discharge more than 300 flashbulbs without changing the battery. The folding shade consists of 13 fan-shaped blades. The body of the flash gun is plastic and the folded reflector in its vinyl case fits any pocket or purse.

Minolta Lens Shade

A lens shade should be used to prevent unnecessary and stray light from entering the lens, which will cause glare spots on the picture, and is especially essential in synchro-flash work.

Minolta Filters

Filters are used to obtain nearly similar effects in the prints as seen with the naked eye or to secure other special depiction aimed at. Minolta filters will enable you to take better and more elaborate pictures than is possible without them.

Furnished in UV, and Yellow, Orange, Red, and Green origins for black and white films. Color filters both for daylight type and artificial light type color films.

**Emulsion-Speed Values
Comparative Table**

ASA	DIN	SCHEINER
10	11 / 10	22
12	12 / 10	23
25	15 / 10	26
32	16 / 10	27
50	18 / 10	29
100	21 / 10	32
200	24 / 10	35
400	27 / 10	38
800	30 / 10	41
1600	33 / 10	44