

MINOLTA SRT 100x

101b

303b

OWNER'S MANUAL

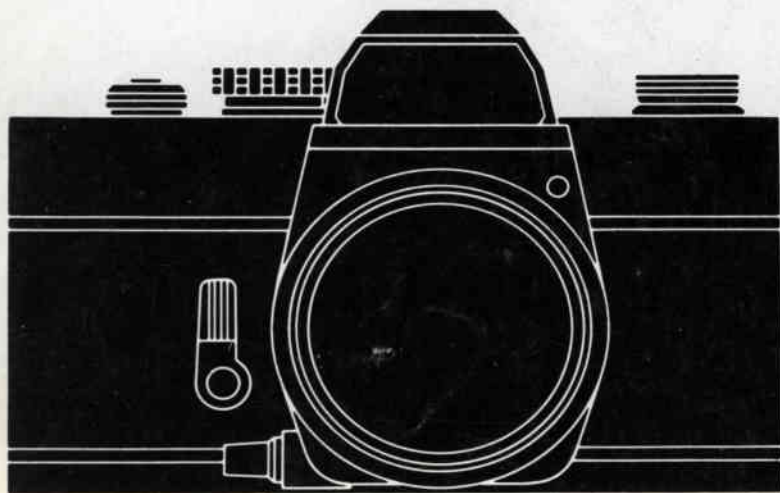

E



This manual is for reference and historical purposes, all rights reserved.

This page is copyright© by M. Butkus, NJ.

This page may not be sold or distributed without the expressed permission of the producer

I have no connection with any camera company

On-line camera manual library

This is the full text and images from the manual. This may take 3 full minutes for the PDF file to download.

If you find this manual useful, how about a donation of \$3 to: M. Butkus, 29 Lake Ave., High Bridge, NJ 08829-1701 and send your e-mail address so I can thank you. Most other places would charge you \$7.50 for a electronic copy or \$18.00 for a hard to read Xerox copy.

This will allow me to continue to buy new manuals and pay their shipping costs.

It'll make you feel better, won't it?

**If you use Pay Pal or wish to use your credit card,
click on the secure site on my main page.**

The Minolta SR-T 100x, 101b, and 303b are top-quality single-lens reflexes each precision designed and built to give you greater speed and ease of operation and handling. Accurate exposure is yours by simply aligning needles in the finder or adjusting manually as you prefer. Light metering is by Minolta's exclusive CLC (Contrast Light Compensator) system through the lens for most satisfactory results in most lighting situations without adjustments or special techniques. The SR-T 101b and 303b incorporate further features for even greater convenience and versatility. Each SR-T model, however, is also an integral part of the Minolta SLR system and uses all interchangeable lenses and applicable system accessories for more versatility in advanced or specialized use.

Before using your camera for the first time, study this manual all the way through — or at least all the sections needed to cover your own photographic needs. As you read, attach a lens to the camera body (see p. 42) if necessary, load batteries, and handle your SR-T and acquaint yourself with its parts and features. Then load it with film and proceed to actual picture taking. In this way, you can take good photos and begin to realize the broad potential of your SR-T right from the start. Be sure to keep this manual for reference later as necessary.

CONTENTS

MAIN SR-T FEATURES	4	STOP-DOWN BUTTON	20
NOTES ON THIS MANUAL	5	METERING METHODS	20
NAMES OF PARTS	6	HOLDING THE CAMERA	21
SUMMARY OF OPERATION	8	VIEWFINDER	22
BATTERY AND POWER	10	METERING WITH CLC	23
Installing battery	10	SETTING EXPOSURE	
Testing battery	11	Match-needle exposure control	24
Switching meter on and off	12	Exposure adjustment or full-	
Cold-weather operation	13	manual operation	25
FILM-ADVANCE LEVER AND		"B" (bulb) setting	26
EXPOSURE COUNTER	14	EXPOSURE-CONTROL	
LOADING AND ADVANCING FILM	15	FUNDAMENTALS	27
FILM SPEED	18	WAYS OF USING SR-T EXPOSURE	
Setting film speed	18	CONTROL	28
ASA/DIN conversion scale	19		
Memo holder	19		

FOCUSING	30
Depth-of-field scale	31
Depth-of-field preview	32
Infrared index	32
Film-plane index	32
RELEASING THE SHUTTER	33
REWINDING AND UNLOADING FILM ..	34
FLASH PHOTOGRAPHY	36
SELF-TIMER	39
MULTIPLE EXPOSURES	40
ATTACHING AND REMOVING LENSES ..	42

USING OTHER THAN MD OR MC LENSES

Auto Rokkor lenses	43
RF (mirror-type) and manual-diaphragm lenses	43
CAMERA SPECIFICATIONS	44
STANDARD LENS SPECIFICATIONS ...	46
CARE AND STORAGE	47

MAIN SR-T FEATURES

Superior through-the-lens exposure system

- Exposure readings are taken with the lens at full aperture for greatest metering accuracy and clearest, brightest viewing and focusing.
- Meter and follower needles visible in the viewfinder show correct or adjusted exposure at a glance with any shutter-aperture combination.
- Since only the light to strike the film is measured, there is no need to compensate for filters, greater-than-normal extension, and so on.
- The exclusive CLC metering system combines advantages of spot and averaging types to yield optimum exposure without special adjustments even in high-contrast lighting situations.

Direct-Contact "Hot Shoe"

This accepts either cordless units or conventional ones with cords and provides X-type flash synchronization.

World-renowned Minolta lenses

MD or MC lenses permit full-aperture TTL

operation with an SR-T, while any other interchangeable Rokkor ever made can be used with the stop-down method. Either way, you benefit from top Minolta quality, computer design, and exclusive Achromatic coating.

Complete system accessories

A full line of over 150 quality Minolta and adapted Leitz accessories makes for maximum versatility with your SR-T.

Added SR-T 101b features

To the basic features above, the 101b model adds a convenient selftimer, shutter-speed display in the finder and a useful memo holder on the back of the camera.

Further SR-T 303b features

The 303b offers the additional advantages of multiple-exposure capability, Minolta's exclusive Safe Load Signal that monitors film alignment and advance, plus aperture readout while viewing.

NOTES ON THIS MANUAL

This is a combined instruction manual for use with the SR-T 100x, SR-T 101b, and SR-T 303b. For this reason, some sections may not apply to your model, and some illustrations may show features different from the camera you own. Proper operation is indicated for all three models, however, and differences between them are clearly indicated in instructions and specifications.

Unless otherwise indicated, illustrations in this book show the SR-T 303b, the series model with the full complement of features, with appropriate notes to distinguish them for the 101b and 100x. The 50mm f/1.4 MD Rokkor lens is used in illustrations; there is of course no fundamental difference in use between this and the other standard lenses, the 50mm f/1.7 MD Rokkor and 58mm f/1.2 MC Rokkor for the SR-T 101b and 303b, the 50mm f/2 MC Rokkor for the SR-T 100x.

NAMES OF PARTS

6



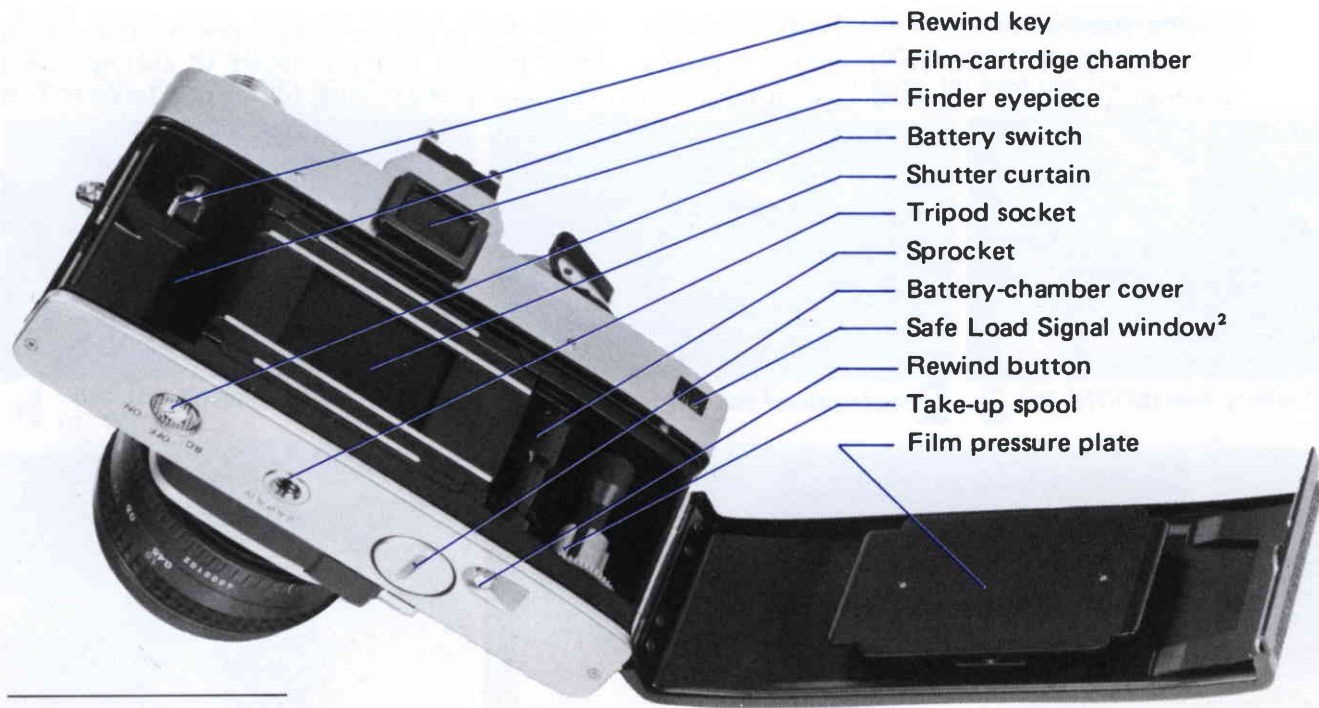

-
1. Not on SR-T 100x
 2. Only on SR-T 303b

SUMMARY OF OPERATION

8

The steps pictured on this page outline use of your SR-T with match-needle exposure control. They give a general idea of how very

easy it is to get perfectly exposed pictures with this camera and are keyed to corresponding sections of the manual for ready reference. This

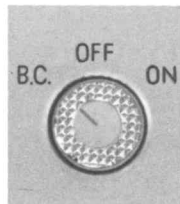

1 Check battery (see p. 11).

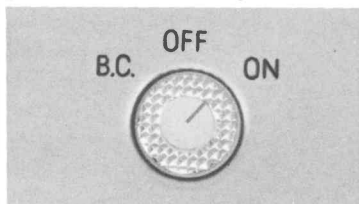
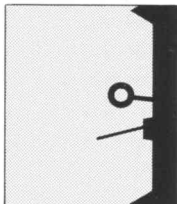

2 Move power switch to "ON"(p. 12)



3 Open back cover (p. 15).



7 Set shutter and aperture (p. 24).



8 . . . to align needles in finder (p. 25)

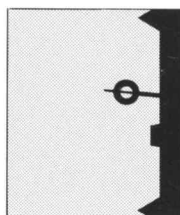

9 Adjust focus (p. 30).

brief guide may also be useful as a quick refresher for good results after you have not used the camera for some time. It is not,

however, a substitute for the detailed instructions in the rest of this manual, which should be thoroughly studied for best results.

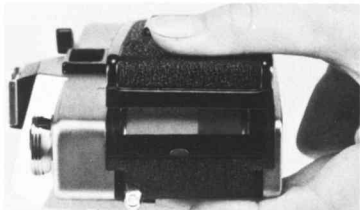

4 Load film properly; close cover (p. 17).



5 Advance film to "1" (p. 17).



6 Set film speed (p. 18).



10 Release shutter (p. 33).

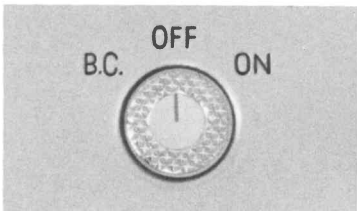

11 Turn power off (p. 12).

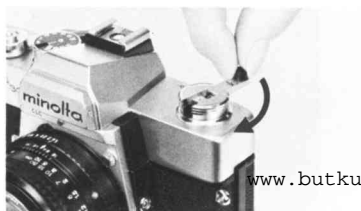

12 Rewind and remove film (p. 34).

BATTERY AND POWER

The meter in your SR-T is powered by a 1.35v "button-cell" mercury battery, Eveready EPX-625 or EPX-13 or equivalent.

Installing battery

1. Using a coin or similar object, turn the battery-chamber cover counterclockwise and remove it.

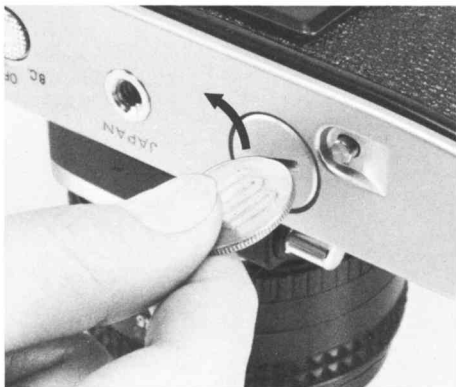

2. After wiping terminals with a clean, dry cloth and handling only by the edges, insert one of the specified batteries plus (+) side out into the chamber.
3. Replace the cover by aligning it carefully and screwing it in clockwise until it is secure.



CAUTION

- Do not touch the battery terminals with moist or dirty fingers, as this may cause it to become inoperative.
- If the camera is not to be used for over a month, the battery should be removed and stored in a cool dry place.
- Do not discard a mercury battery in a fire or attempt to open or break it.

Testing battery

Use your thumb to turn the index of the battery switch on the bottom of the camera to "B.C." If the meter needle moves to and remains fixed within the square battery-check

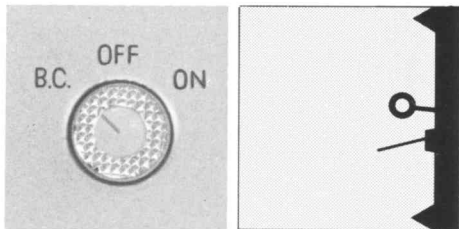

mark in the finder as shown, the battery is serviceable.

Test the battery immediately after installing it. If the meter needle does not point as indicated, make sure that the battery is fresh and has been inserted correctly.

The battery should be tested from time to time thereafter, preferably before starting each new roll of film and after it has not been used for a period of time, particularly before starting picture-taking sessions or trips. A battery will generally last for over a year in proper normal use.

CAUTION

Do not leave the switch set at the B.C. position, as this may cause improper exposure with the match-needle method and will place undue load on the battery.

Switching meter on and off

To activate the metering system, move the index of the battery switch to "ON." This will cause the meter needle in the finder to move if there are sufficient light and battery power.

When not using the camera, it is advisable to turn the switch index to the "OFF" position to prevent needless battery drain.

NOTE

The metering system does not work correctly when the stop-down button is at its stop-down position with MD or MC lenses mounted on the camera.

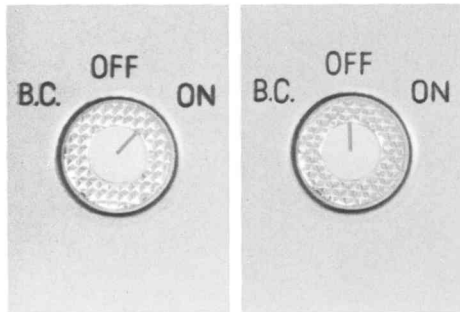

Cold-weather operation

Batteries by nature tend to decrease in capacity as the temperature goes down.

If an *old* battery is used at temperatures below 0°C (32°F), the meter indication may not be correct. You should thus replace the battery with a fresh one before using your SR-T in cold weather. It may also be a good idea to carry an extra fresh battery warm in an inside pocket to exchange with the one in the camera from time to time as necessary.

Though mechanical operation should be satisfactory down to considerably lower temperatures, guard against abrupt changes of temperature at such levels.

For information about using your SR-T at temperatures below about minus 20°C (-4°F), consult an authorized Minolta service facility.



FILM-ADVANCE LEVER AND EXPOSURE COUNTER

14

The film-advance lever is designed with 20° unengaged movement before the beginning of its engaged stroke to allow swinging it out from the body so that the right thumb will fit comfortably behind it. Continuing to move the lever in one or more strokes through its engaged angle of 150° until it springs back advances film and exposure counter and cocks the shutter for the next exposure. (To cock the shutter without advancing film with the SR-T 303b, see p. 40).

When the lever stops part way through its engaged angle at the end of a film, never attempt to force it farther. (See p. 34 for instructions on rewinding and unloading film.)

The exposure counter advances one graduation for each exposure made. It will not move more than one graduation past "36" regardless of the number of multiple exposures that may be made with the SR-T 303b. The counter automatically resets for film loading when the camera back is opened.



LOADING AND ADVANCING FILM

1. Pull out on the back-cover release knob until the camera back springs open.

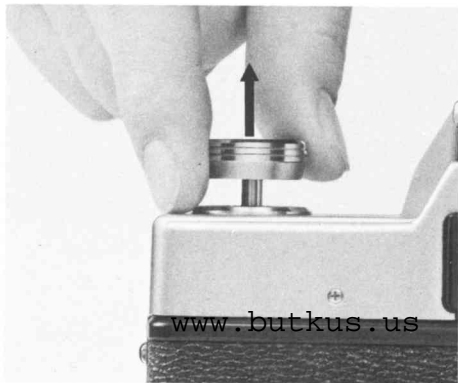

2. Leaving the knob pulled out, position a film cartridge in the chamber with the projecting-spool end toward the bottom of the camera. Then push the back-cover release knob all the way in, rotating it slightly to do so if necessary.

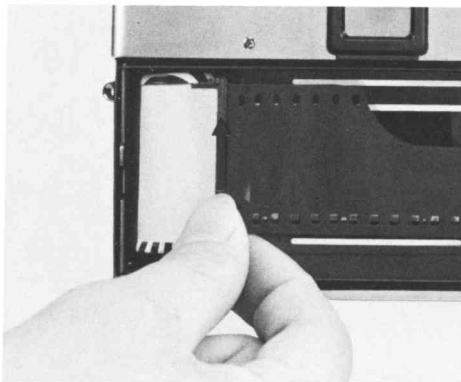

3. Insert a piece on the film leader about four or five sprocket holes from the end behind one of the tabs on the take-up spool as shown so that the leader end forms a secure loop when wound around the spool.

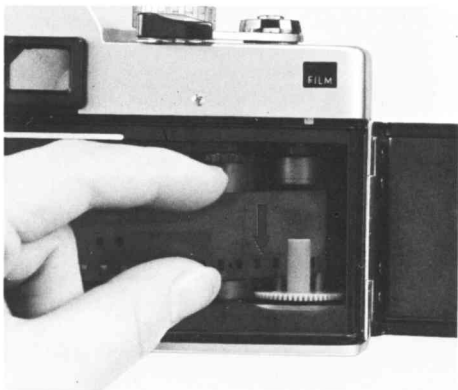

4. Operate the film-advance lever slowly until the film has begun to wind firmly around the take-up spool and the sprocket teeth are engaged with holes on both edges of the film. If the advance lever locks at the end of a full stroke during this procedure, release the shutter and continue.

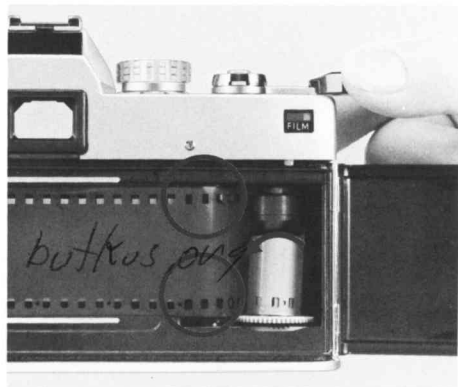

5. With the SR-T 100x and 101b, press down firmly on the film with the fingers between the sprocket holes and the edge of the film on the same side as shown. While doing this to prevent the film from moving, take up any slack in the cartridge by folding out the rewind crank and turning in the direction of the arrow until resistance is felt. This need not be done with the SR-T 303b.
6. Close the camera back and push in on it until it clicks locked.

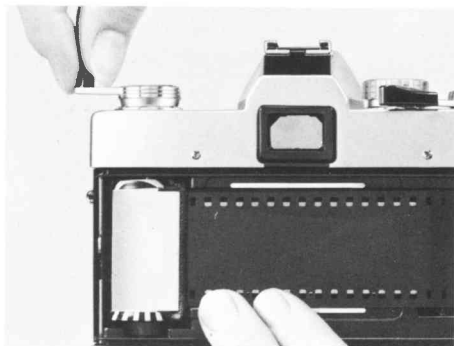

7. Release the shutter and advance film until "1" on the exposure counter dial is aligned with the index. With the SR-T 100x and 101b, watch the rewind crank while doing this; rotation of the crank during the full engaged stroke in the direction opposite that of the arrow indicates that film is advancing properly. With the SR-T 303b, proper film alignment and advance is indicated by the



appearance of a red bar from the right in the SLS window over the word "FILM." If the crank rotates during only a small part of the stroke or not at all on the SR-T 100x and 101b or if the red bar does not appear on the SR-T 303b, repeat steps 1 through 6. With the SR-T 303b, the red signal will move gradually toward the left as you take the first 15 or so frames, indicating that film is advancing properly.

CAUTION

Film should be handled and loading done in subdued light — at least shaded from direct sunlight by the body.

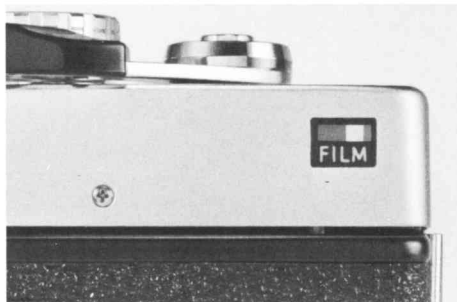

FILM SPEED

Each film on the market has an ASA or DIN exposure-index number to indicate its sensitivity to light. For correct match-needle exposure, the meter of your SR-T must be set for the effective exposure index of the film in use.

Setting film speed

To do this, lift up on the milled ring of the shutter-speed dial and turn it until the proper ASA indication appears centered in the film-speed window and locks in that position when



the ring is released. Dots between numbered graduations indicate ASA numbers as follows:

6	200
• 8	• 250
• 10	• 320
12	400
• 16	• 500
• 20	• 640
25	800
• 32	• 1000
• 40	• 1250
50	1600
• 64	• 2000
• 80	• 2500
100	3200
• 125	• 4000
• 160	• 5000
	6400

ASA/DIN conversion scale

A convenient scale for converting DIN to ASA film-speed ratings is located on the back cover of the camera.

Memo holder

Around the ASA/DIN conversion table on the SR-T 101b and 303b is a convenient frame that can be used to keep memos handy with the camera. It is just the right size to hold the film-box end, which can be inserted as a reminder of the film in use.

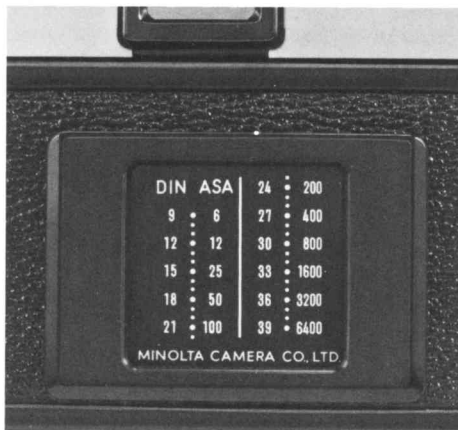

STOP-DOWN BUTTON

The stop-down button on your SR-T enables depth-of-field preview (see p. 32) and stop-down metering (see right) in addition to usual full-aperture metering.

With this button at its normal outer rest position, the lens diaphragm remains at full aperture for metering regardless of the f-number set by the lens aperture ring, closing down to the preset aperture only at the instant of exposure.

Pushing the button all the way in closes the lens down to the preset aperture as long as the button is held there. When the button is released, it returns to its outer full-aperture position.



METERING METHODS

With Minolta MD or MC (meter-coupled) lenses, metering is done with the stop-down button at its full-aperture rest position for greatest sensitivity and maximum brightness for utmost ease of composing and focusing except at the moment of exposure. (Do not push the stop-down button when MD or MC lenses are being used normally.)

Stop-down metering is used for lenses other than the MD or MC types (see p. 43) or for any lens used with non-coupled extension tubes or reversed as with the Reverse Ring II (in accordance with applicable instructions).

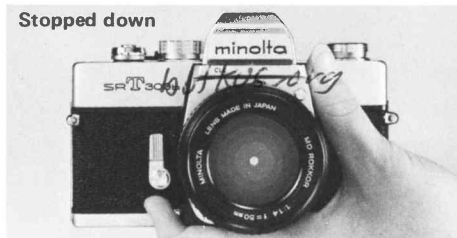

HOLDING THE CAMERA

Your camera should be held in a comfortable position that will provide sufficient steadiness. A recommendable way that permits ready operation of important controls is shown here.

To hold the camera horizontally, cradle the bottom of it in the palm of the left hand with the thumb and index or middle finger on the focusing grip of the lens. The thumb and middle or ring finger of the same hand can be used to turn the aperture ring. Grasp the



camera body firmly with the right hand as shown so that the index finger rests on the shutter-release button. In this position, the thumb can conveniently operate the film-advance lever.

The camera may be rotated to a vertical position when held this way, the only difference being that its rewind-crank end will rest in the palm of the left hand.



VIEWFINDER

22

As you look through the viewfinder of your SR-T, you can see:

- 1 **Meter needle** (responds to light)
- 2 **Follower** (align with meter needle for correct match-needle exposure)
- 3 **Metering range limits** (match-needle exposure will not be correct when meter needle is outside these)
- 4 **Battery-check mark** (meter needle points to this to show sufficient power when switch on base turned to "B.C.")
- 5 **Focusing spot**, microprism type in SR-T 100x and 101b, split-image/microprism type (shown here) in the 303b.

In the 101b and 303b, you can also see:

- 6 **Shutter-speed scale with indicator** to show speed set

The 303b further shows above frame:

- 7 **F-number** of lens aperture set.

For further details, see the following sections on exposure control and focusing, and on battery checking (p. 11).

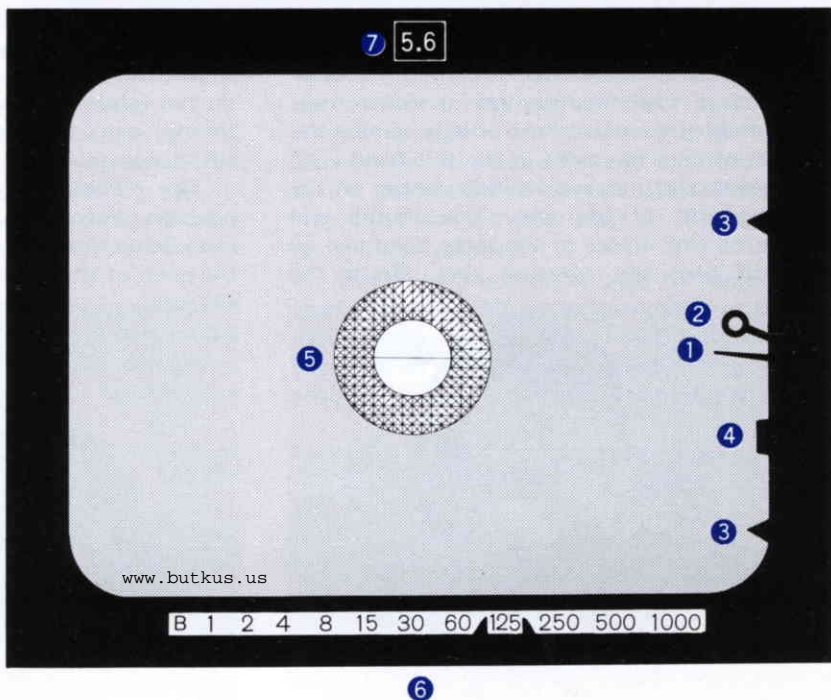

METERING WITH CLC

Minolta's exclusive CLC ("Contrast Light Compensator") metering system employs two CdS cells mounted on the pentaprism to take separate, overlapping light readings.

These cells are circuited so that the reading of each affects that of the other to automatically yield optimum exposure in both normal and most high-contrast situations. For best results, the photographer should thus generally not make compensatory adjustment for such differences. One exception is that exposure should generally be decreased one to two stops if the most important subject area is much brighter than the rest of the picture (e.g., is in a spotlight or shaft of sunlight). Some photographers also prefer to increase exposure a half stop or more with a backlighted subject or one whose most important area is considerably darker than the area surrounding it. (Exposure adjustment instructions are given on p. 25).

Though the SR-T's special system and finder are designed to minimize the effect on the meter of light entering through the finder eyepiece under usual conditions, care must be exercised to prevent this especially if you wear

eyeglasses. Use of a rubber finder eyecup is further recommended when the subject is in shade and the camera is in sunlight, when bright sidelight falls between eye and eyepiece, or when stop-down metering is used, particularly at small apertures.

Besides offering exceptionally long service life and consistent conversion of light to electrical values, the CdS cells in your SR-T, like all others, have characteristics comparable to human vision. They are able to "see" about the same light and color as your eyes and photo film can; this is a great advantage for accurate exposure. Like your eyes, however, their time of response varies with the intensity of the light falling on them. It thus takes them a while to become accustomed to low light levels after exposure to bright light. For accurate exposure, you should thus be careful not to point the camera at very bright natural or artificial light sources before making exposures. And you should give your CdS electric eyes a short time to get accustomed to darker conditions, when, for example, taking pictures in shadow or indoors after shooting in bright sunlight.

SETTING EXPOSURE

Match-needle exposure control

1. Look through the finder. With a serviceable battery and the battery switch on (see p. 12), the fine meter needle (silhouetted at the right in the frame when the camera is held horizontally) will move in response to sufficient light (the more light, the farther toward the bottom of the frame it will go). Proper exposure can only be achieved using the meter if the needle is between the two pointed metering-range limit marks projecting into the frame. If the needle does not move into this area from above the upper mark, more light on the meter cells is needed (as by using a lens of greater maximum aperture, a lighter subject, more illumination, etc.). If the needle moves below the lower mark, light reaching the cells must be reduced (as with an ND or other filter over the lens, a darker subject, less illumination, etc.).
2. As soon as the meter needle stops moving with your subject composed in the frame, turn the shutter-speed dial (but not to "B" – see p. 26) and/or lens aperture ring *each*

only in click-stops until the circletipped follower is lined up with the meter needle as nearly as possible (as in illustration A on the next page).

The location of the follower and the angle through which it will move depends upon the film-speed setting as well as the shutter-

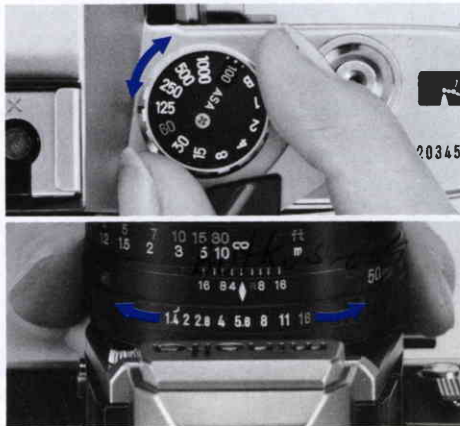

speed and aperture settings. If the follower cannot be moved into alignment, one of these settings must be adjusted to allow it. It may be more usual to set the shutter-speed first according to the subject movement and effect desired, though the aperture may of course be set first if appropriate (see pp. 28-29).

3. After the needles are aligned, simply confirm focus (see p. 30) and composition and release the shutter (p. 33).

A: Correct metered exposure **B: More exposure** **C: Less exposure**

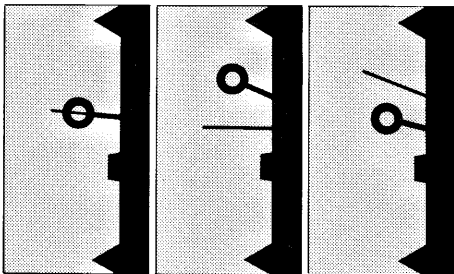

Exposure adjustment or full-manual operation

Aperture or shutter speed can if desired be adjusted so as to give more or less exposure than the meter indicates proper. With MD or MC lenses, each click stop on the aperture ring represents a half-stop difference in exposure (see p. 27), while moving the shutter-speed dial from one click-stop to another changes exposure a full stop. With more exposure, the follower will appear nearer the top of the horizontal frame (see Illustration B at left); with less, on the other side of the needle toward the bottom (Illustration C). Needle alignment may of course be completely disregarded for full-manual exposure control.

“B” (bulb) setting

With the “B” on the shutter-speed selector dial aligned with the red index, the shutter will open when the release is depressed and remain open until it is released. The match-needle method is not intended to produce correct exposure at this setting.

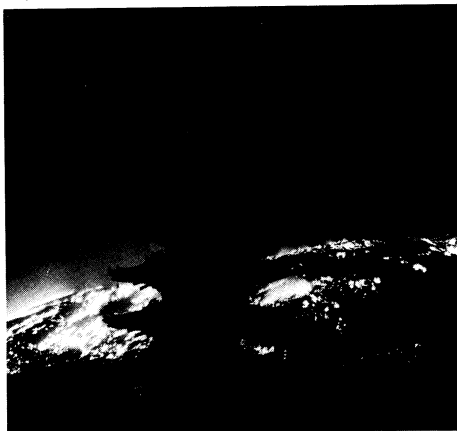

With the SR-T 101b and 303b, the shutter setting will be indicated on the scale below the frame in the finder. With the SR-T 303b, the aperture set will also appear centered above the frame with most lenses. (Positions of shutter-speed and f-number indications are shown on p. 22.)

NOTE

- Shutter-speed dial and aperture ring should not be set between their click-stops.
- Do not use the “B” shutter setting with match-needle exposure control.

EXPOSURE-CONTROL FUNDAMENTALS

The two camera exposure-control settings are lens opening (aperture) and shutter speed. The size of the aperture determines the amount or volume of light reaching the film from a given subject and lighting. The shutter speed determines the length of time this light acts upon the film. Apertures are expressed in f-numbers, which are larger for small openings and vice versa (e.g., f/16 represents a small opening, f/2 a large one). Shutter speeds are expressed in seconds or fractions thereof, which are generally the reciprocals of the numbers shown on shutter-speed scales. (e.g., 60 = 1/60 sec., but 1 = 1 full second) At usual apertures, each f-number setting (e.g., f/8) lets in twice as much light as the next numerically larger one (f/11) and half as much as the next smaller (f/5.6)*. Similarly, each shutter speed (e.g., 1/60 sec.) allows light to strike the film twice as

long as the next higher speed (1/125) and half as long as the next lower one (1/30). The interval between two standard f-numbers (say, f/4 and f/5.6) or shutter speeds (say, 1/15 and 1/30) is one "stop." Total exposure on the film is determined by the combination of aperture and speed. Other things being equal, using the next smaller f-number (i.e., giving one stop more exposure) will balance using the next higher shutter speed (i.e., giving one stop less exposure), and so on. A great range of combinations (e.g., f/5.6 at 1/30, f/4 at 1/60, f/2.8 at 1/125, f/2 at 1/250, etc.) will thus yield the same total exposure. The specific combination you choose under given lighting conditions will depend upon the degree to which you want the greater depth of field (see p. 31) of smaller apertures and the greater movement-blur preventing ability of faster speeds. These factors as they relate to exposure control with your SR-T are discussed in the following section.

* In practice, this varies somewhat at large or maximum apertures, but your SR-T and Minolta MD or MC lenses have built-in compensation for this to give you most satisfactory exposure.

WAYS OF USING SR-T EXPOSURE CONTROL

Your SR-T's match-needle system offers a quick, easy, and flexible method of obtaining proper exposure that offers considerable control over results to suit the conditions and yourself.

General use

For usual good personal pictures, such as Example A below, where no particular effect is desired, simply set a shutter speed (say, about 1/125 sec.) fast enough to sufficiently "stop" subject motion and guard against blur from camera movement (see p. 33) that will result in correct exposure at a medium aperture (say, about f/8) that will provide as much depth of field (see p. 31) as possible.

A: Medium shutter speed and lens aperture



Shutter Priority

There may be times when the subject or effect you want may make it most important to select a particular shutter speed. In this case first set the required speed (except the "B" setting), then use the match-needle system to set the aperture that will give proper exposure at that speed. High shutter speeds such as 1/500 to 1/1000 sec. can "freeze" fast action, as in Example B below. Such slow speeds as 1/2 to 1 sec. can be used to emphasize subject flow or motion, as in Example C.

Aperture priority

At other times, it may be most important to select a lens opening to obtain a particular

B: High shutter speed



effect, such as rendering a certain range in sharp focus or emphasizing a subject against an out-of-focus background. In this case, set the desired f-number on the aperture ring, then use the match-needle system to set the shutter speed for proper exposure at the setting. Small f-numbers yield a relatively shallow field of sharp focus, as in example D at right, while large f-numbers give greater depth of field, as in Example E. To judge depth of sharp focus, use the depth-of-field scale (see p. 31) or stop-down button (p. 32).

No matter how the camera is used, it is important to support it (see p. 21) and release the shutter properly (p. 33). In accordance with the above principles, the match-needle indica-

tion may of course be adjusted (as indicated p. 25) or exposure set manually with or without reference to a separate meter.

C: Low shutter speed



D: Large lens opening



E: Small lens opening



FOCUSING

The SR-T 100x and 101b have a microprism focusing spot centered in the finder frame's mat field, while the 303b has a microprism band surrounding a split-image spot. To focus visually with the microprism field, look through the finder with the lens at full aperture and turn the focusing collar until the subject image in the field appears clear rather than broken up or shimmering and blends with that on the mat screen around it.

To use the split-image spot, turn the focusing collar until the upper and lower images are exactly aligned with no broken lines between them.

Out of focus



The most satisfactory focusing aid and method depend upon the conditions and the personal preference of the photographer. In general, you may find a microprism field best for subjects without vertical lines using lenses from about 35mm through 100mm focal length, the plain mat field for longer telephoto lenses or macro or other work involving considerable extension, and the split-image spot for subjects with vertical lines and with wideangle lenses.

The camera can also be scale-focused or prefocused by aligning the desired value on the distance scale with the index on the lens barrel.



Depth-of-field scale

The distance behind and in front of the focused distance within which the image appears acceptably sharp is called the depth of field. Besides being greater the shorter the focal length of the lens and vice versa, this increases as the lens is stopped down and becomes greater the farther from the camera the lens is focused. It is at its least for any given lens in normal mounting when the lens is at maximum aperture (as when metering and focusing normally with Minolta MD or MC lenses) and at minimum focusing distance.

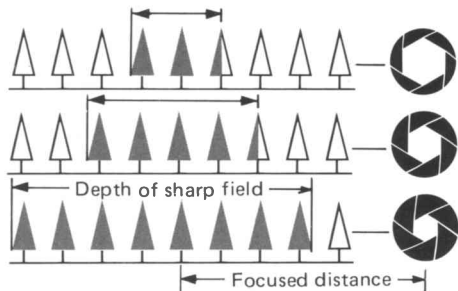

The near and far limits of acceptable sharpness can be determined from the depth-of-field scale on the lens barrel. With the lens focused at a given point, the image will be in satisfactory focus from the nearer value to the farther value on the distance scale indicated by the depth-of-field scale marks for the aperture to be used.

For example, if a 50mm lens is focused at 5m (about 16 ft.) and the aperture is $f/8$, the appropriate graduations to left and right of the index on the depth-of-field scale indicate acceptable sharpness from about 3.4m to 9.7m (approx. 11 to 32 ft.).

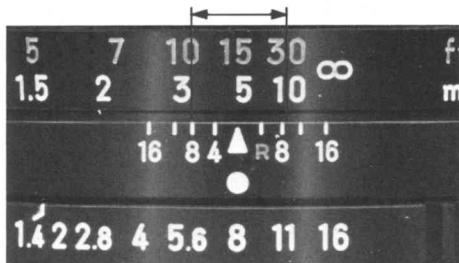

Depth-of-field preview

Depth-of-field at any aperture and focusing distance can be previewed visually by pushing the stop-down button all the way in to its stop-down position (see p. 20). This will stop the diaphragm down to the aperture corresponding to the f-number preset on the aperture ring, allowing you to see through the viewfinder about how much of the subject is acceptably sharp.

Releasing the stop-down button will reopen the diaphragm to full aperture.

Infrared index

For proper focus when making pictures with infrared radiation, first focus your subject with visible light as described above, then turn the focusing ring to the right to align the point of proper focus on the distance scale with the index designated with small red "R" in the depth-of-field scale.

Film-plane index

The \oplus symbol on the camera top plate to the left of the viewfinder indicates the exact

plane occupied by the film in the camera. This can be used to measure distance from subject to film precisely where desired for photomacrography, close-ups, etc.

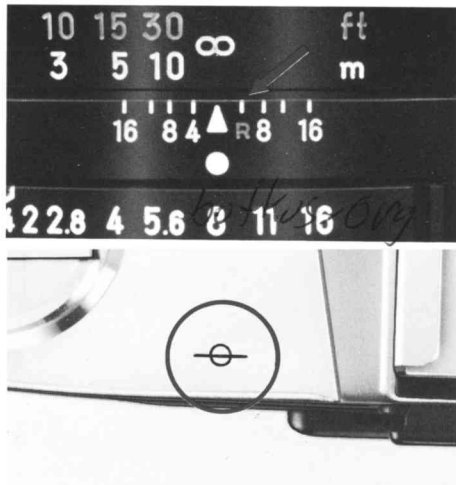

RELEASING THE SHUTTER

The way the camera is supported (see p. 21) when exposures are made and how the shutter is released are as important as focusing for best photographic results; and to avoid blurred pictures due to camera movement during exposure, these factors become more critical the slower the shutter speed.

You may wish to regard a shutter speed of 1/30 sec. as the reference point to gauge the chance of camera movement during exposure. At speeds lower than this, you should pay special attention to both camera and subject movement in taking pictures.

With the possible exception of highest speeds, the camera or hands holding it should generally be firmly steadied against your face or body when you release the shutter.

At slower speeds, it is advisable to steady the camera against a doorframe, post, or other firm support while depressing the release.

The shutter should always be released with a slow, steady squeeze — never a quick jab — preferably while holding your breath.

For maximum sharpness when making exposures too long to permit hand-holding the camera, mount it on a tripod using the built-in socket on the bottom and trip the shutter with a cable release screwed into the threaded socket provided in the shutter-release button.

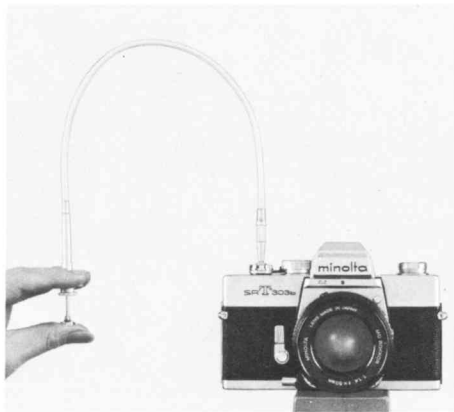

REWINDING AND UNLOADING FILM

34

1. Push the rewind button.

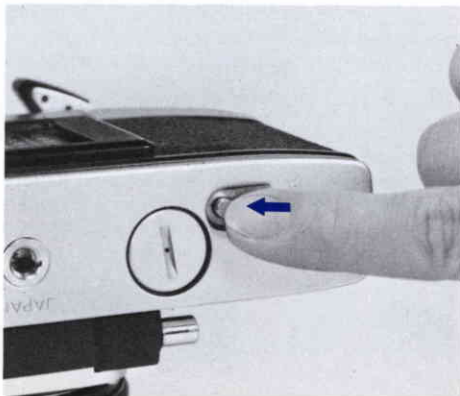

2. Unfold the rewind crank and turn it in the direction indicated by the arrow on it until you feel tension on the film increase, then disappear, and the crank turns freely. With

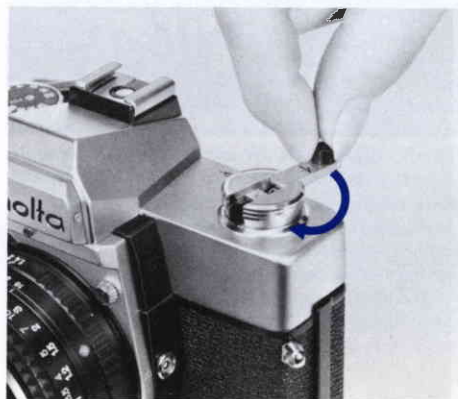

the SR-T 303b, the red bar will move to the right in the SLS window and then disappear from it as the film is being rewound.



3. When you are certain that the film is completely rewound, pull out on the back-cover release knob to open the back and remove the cartridge.

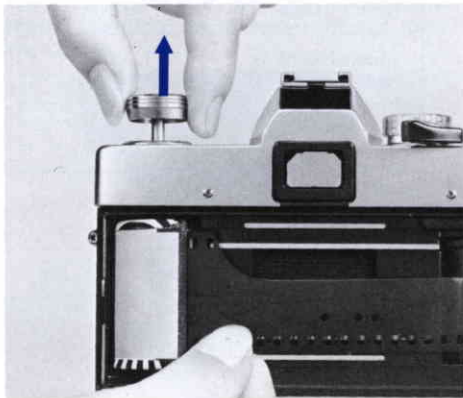

FLASH PHOTOGRAPHY

Synchronization

Your SR-T has shutter contacts for X flash synchronization as follows:

Type of flash	Shutter settings for proper sync.
Electronic flash ("strobe")	B, 1, 2, 4, 8, 15, 30, 60 only
Most class M or MF flashbulbs	B, 1, 2, 4, 8, 15 only
Class FP flashbulbs	B, 1, 2, 4, 8, 15 only

NOTE

The "60" on the shutter-speed dial is colored red to indicate that 1/60 sec. is the recommended speed for X-delay flash, though slower speeds as indicated can be used under certain conditions if desired for particular effects. Be sure not to use speeds faster than 1/60, (i.e., 1/125 and upward) with electronic or auto-flash units.

Connecting flash units

Bracket-type flash units (such as Minolta's Auto Electroflash 450) are physically attached to your SR-T by means of its tripod socket and usually connected electrically by means of a sync. cord with a PC terminal.



Clip-on-type units (such as Minolta's Auto Electroflash 25) are physically attached by sliding them into the accessory shoe on top of the camera.

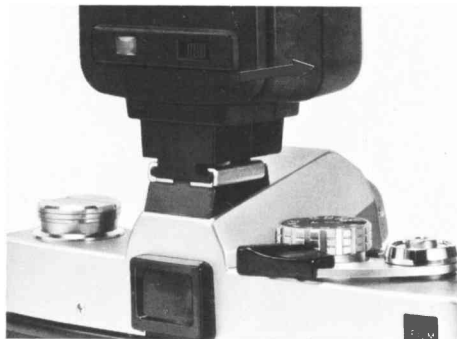

With cordless flash units, connection for X sync. is obtained by simply sliding the unit all the way into the hot shoe. For units with cords, connection may also be made via the X terminal.

The hot-shoe contacts are disconnected to avoid shocks when a unit is not inserted.



SELF-TIMER

The self-timer built into your SR-T 101b and 303b can be used to delay release of the shutter for about 10 seconds after actuation.

To operate it:

1. Advance film.
2. Cock the self-timer by moving the lever counterclockwise as far as it will go (about 80°).
3. To start the self-timer, push the small release button which is hidden under the free end of the lever when in its rest position. If the shutter is not cocked, the self-timer will stop operating part way through its cycle; it can be reset either before or after advancing film.

You can override the self-timer's release of the shutter by pushing the shutter-release button to trip the shutter at any time before the self-timer has started operating.

You can interrupt the self-timer's operation at any time and can reset the lever to its cocked position after it is halfway through its delay.



MULTIPLE EXPOSURES

To intentionally make more than one exposure on a single frame of film with the SR-T 303b only:

1. Make the first exposure in the usual way.
2. Push the rewind button on the bottom of the camera. (Do not continue depressing the button while film is being advanced.)

3. Operate the film-advance lever. This will cock the shutter for the next exposure, but film will not advance since the rewind button has been pushed.

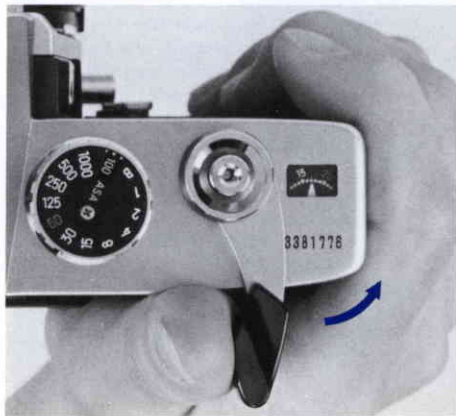
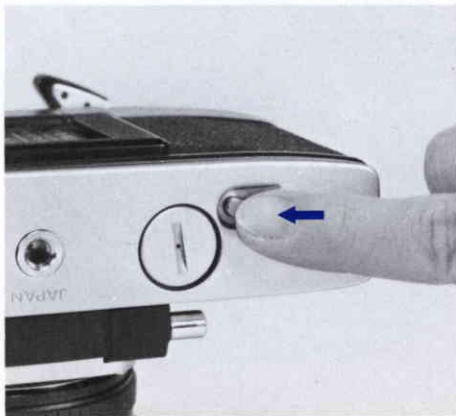

4. Make your second exposure.
5. Then repeat steps 2 and 3 above as many times as desired to make further exposures.
6. After the last multiple exposure, advance film to the next frame in the usual way without pushing the rewind button.

NOTE

- The exposure counter will advance as usual each time the film-advance lever is operated.
- Remember that exposure adjustment may be necessary or desirable when making multiple exposures. This can be easily accomplished as indicated on p. 25, but the exact adjustment will depend upon the number of exposures and the effect desired.



ATTACHING AND REMOVING LENSES

42

To attach

Align the red dot on the lens barrel with the red dot on the camera body; insert the lens bayonet into the mount; and turn the lens clockwise until it locks into place with a click.



To remove

While pushing the lens-release button toward the lens as shown, turn the lens counter-clockwise as far as it will go; then lift the lens bayonet out of the mount.



USING OTHER THAN MD OR MC LENSES

Metering and exposure with RF Rokkor (reflex-mirror type), Auto Rokkor, and manual-diaphragm lenses are by the stop-down method as follows:

Auto Rokkor Lenses

1. After focusing, push the stop-down button all the way in (see p. 18).

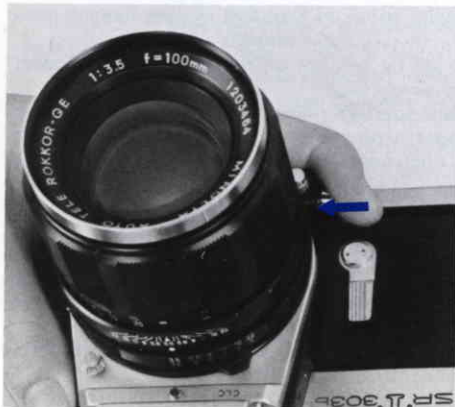

2. Keeping it pushed in, set exposure as explained on pp. 24-26. The viewfinder field will darken as the lens is stopped down, and the microprism field may become unusable due to darkening.
3. Release the button before releasing the shutter. The diaphragm will open unless stop-down metering has been done at full aperture but will automatically stop down to the preset aperture at the moment of exposure.

RF (mirror-type) and manual-diaphragm lenses (viz., Minolta Manual-Preset type, adapted Leitz Photar and Telyt-S)

After focusing, (and without pushing the stop-down button), set exposure as explained on p. 24-26 and release the shutter.

CAMERA SPECIFICATIONS

- Type:** 35mm single-lens reflexes with match-needle/manual exposure control
- Lens mount:** Minolta SLR bayonet, 54° rotating angle; coupling for full-aperture metering and automatic diaphragm control with "MD" or "MC" lenses (stop-down metering used for other Rokkor lenses); button for depth-of-field preview and stop-down metering. (Standard lenses: 50mm f/2 MC Rokkor for SR-T 100x; 50mm f/1.7 or 50mm f/1.4 MD Rokkor, or 58mm f/1.2 MC Rokkor for SR-T 101b and 303b; see p. 46 for specifications)
- Light metering:** Full-aperture TTL type with overlapping readings taken by 2 CdS cells mounted on pentaprism and circuited to provide optimum exposure in both flat-and most contrast-lighted situations; stop-down metering also possible
- Film-speed range:** ASA 6 to 6400 set by selector on shutter-speed dial
- Power:** One 1.35v mercury cell contained in camera base
- Exposure control:** Turning shutter-speed dial and/or lens aperture ring to align follower with meter needle visible in finder yields proper exposure according to metering system indication at the film speed set. Alignment may be disregarded for exposure adjustment of full manual control.
- Metering and match-needle exposure range:** EV 3 to EV 17 (e.g., 1/4 sec. at f/1.4 to 1/1000 at f/11) at ASA 100 with f/1.4 lens
- Shutter:** Horizontal-traverse mechanically controlled focal-plane type; speeds 1, 1/2, 1/4, 1/8, 1/15, 1/30, 1/60, 1/125, 1/250, 1/500, and 1/1000 sec. plus "bulb" setting
- Mirror:** Oversize quick-return type (PO value: 138mm; finder image cutoff negligible even with 1600mm f/11 RF Rokkor extreme telephoto)
- Finder:** Eye-level pentaprism type showing 94% of 24 x 36mm film-frame area
- Magnification:** 0.83X with 50mm lens focused at infinity
- Mat-Fresnel-field focusing screen with centered focusing aid; ϕ 3mm microprism**

spot in SR-T 100x and 101b, $\phi 2.5\text{mm}$ horizontal split-image spot surrounded by 1.5mm microprism band on SR-T 303b

Meter needle and circle-tipped follower for match-needle exposure control, coupled metering-range limits, and battery-check indication all silhouetted within the viewfield; shutter-speed scale and setting indicator visible below the frame in SR-T 101b and 303b; lens aperture set on most Minolta lenses appears above the frame in SR-T 303b.

Flash sync.: X delay; electronic flash synchronizes at 1/60 sec. and all slower settings including B through single PC terminal or hot shoe.

Hot-shoe contact disconnected when a unit not inserted

Film advance: Lever type, single- or multiple-stroke, 150° winding angle after 20° unengaged movement to allow offsetting from body
Advancing-type exposure counter resets automatically when camera back is opened.

Safe Load Signal indicates film alignment and advancing condition on SR-T 303b.

Multiple exposures possible with rewind button on SR-T 303b.

Self-timer: On SR-T 101b and 303b only; lever-type, approx. 10 sec. maximum delay

Other: 4-slot take-up spool; ASA/DIN conversion scale on back cover; conversion scale surrounded by memo holder on SR-T 101b and 303b

Dimensions: 145 x 47.5 x 95mm (5-3/4 x 1-7/8 x 3-3/4 in.) without lens

Weight: SR-T 100x: 675g (23-13/16 oz.), SR-T 101b: 690g (24-5/16 oz.), SR-T 303b: 700g (24-11/16 oz.) without lens

STANDARD LENS SPECIFICATIONS

46

Camera model:	SR-T 100x	SR-T 101b and 303b		
Lens:	50mm f/2 MC Rokkor	50mm f/1.7 MD Rokkor	50mm f/1.4 MD Rokkor	58mm f/1.2 MC Rokkor
Type:	Meter-coupled Gauss-type standard lens			
Construction:	6 elements in 5 groups	6 elements in 5 groups	7 elements in 5 groups	7 elements in 5 groups
Angle of view:	47°	47°	47°	41°
Coating:	Minolta Achromatic			
Min. focusing dist.:	0.5m (1.75 ft.)	0.45m (1.48 ft.)	0.45m (1.75 ft.)	0.6m (2 ft.)
Diaphragm:	Full automatic, meter-coupled			
Aperture scale:	2,2.8,4,5.6,8,11,16	1.7,2.8,4,5.6,8,11,16	1.4,2,2.8,4,5.6,8,11,16	1.2,2,2.8,4,5.6,8,11,16
	Each with full and half click-stops			
Filter thread diam.:	55mm			
Dimensions:	φ65mm x 35.5mm (φ2-9/16" x 1-3/6")	φ64mm x 40mm (φ2-9/16" x 1-5/8")	φ64mm x 40mm (φ2-9/16" x 1-13/16")	φ70.5mm x 54mm (φ2-3/4" x 2-1/8")
Weight:	240g (9-7/16 oz.)	195g (6-7/8 oz.)	245g (8-5/8 oz.)	475g (16-3/4 oz.)

CARE AND STORAGE

- As with all high-precision instruments, no part of your SR-T should ever be forced at any time. If operation is not as you think it should be, carefully restudy the applicable instructions or consult an authorized Minolta service representative.
- Always keep your camera in its case with the lens capped when not in use.
- Never subject your camera to shocks, high heat and/or humidity, water, or harmful chemicals or gases.
- Never lubricate any part of the body or lens.
- Always use a body cap when a lens is not installed on the body. Keep lenses, properly capped front and rear, in their cases when not in use.
- Never touch the shutter blades or anything inside the front of the body with the fingers. These parts and the inside of the back should be dusted with a soft brush from time to time as necessary, with particular care never to exert pressure on the shutter curtain.
- Never touch lens or other glass surfaces with the fingers. If necessary, remove loose matter from them with a blower lens brush. Use special photographic lens tissue or a soft clean cloth to remove smudges or fingerprints with a gentle circular motion. Only if absolutely necessary, the tissue may be moistened very slightly with not more than one drop of a satisfactory quick-evaporating fluid cleaner specially compounded for photographic lenses. *Like other fluids, these must never be dropped directly on the glass surface.*
- Smudges or fingerprints on the mirror may be removed with lens tissue slightly moistened with lens-cleaning fluid as above.
- External camera and lens-barrel — *but not glass* — surfaces may be wiped with a soft, silicone-treated cloth.
- Never leave the shutter or self-timer cocked when the camera is to be stored overnight or longer. It is advisable to operate the film advance and release the shutter once or twice from time to time during extended storage.

- If the camera is not to be used for more than a month, the battery should be removed.
- If the camera is to be stored for a long period of time, body and lens should be returned to their original packing and kept in a cool, dry place away from dust or chemicals, preferably in an airtight container with a drying agent such as silica gel.

Specifications subject to change without notice