

Minolta SR-7

owner's manual



All about your Minolta SR-7

Congratulations! You now own one of the finest cameras in the world. The precision elements contained within it are more than adequate to meet any photographic situation on a professional level.

Your Minolta SR-7 features the world-famous Rokkor F1.4/58mm lens treated with an exclusive Achromatic coating to give you high fidelity sharpness, particularly in color photography. The camera contains an extremely bright penta prism viewing system and a completely automatic pre-set diaphragm. It is also equipped with a highly sensitive CdS light meter coupled to the shutter. Please read this manual carefully so that you may effectively utilize the full potential of your new Minolta SR-7.

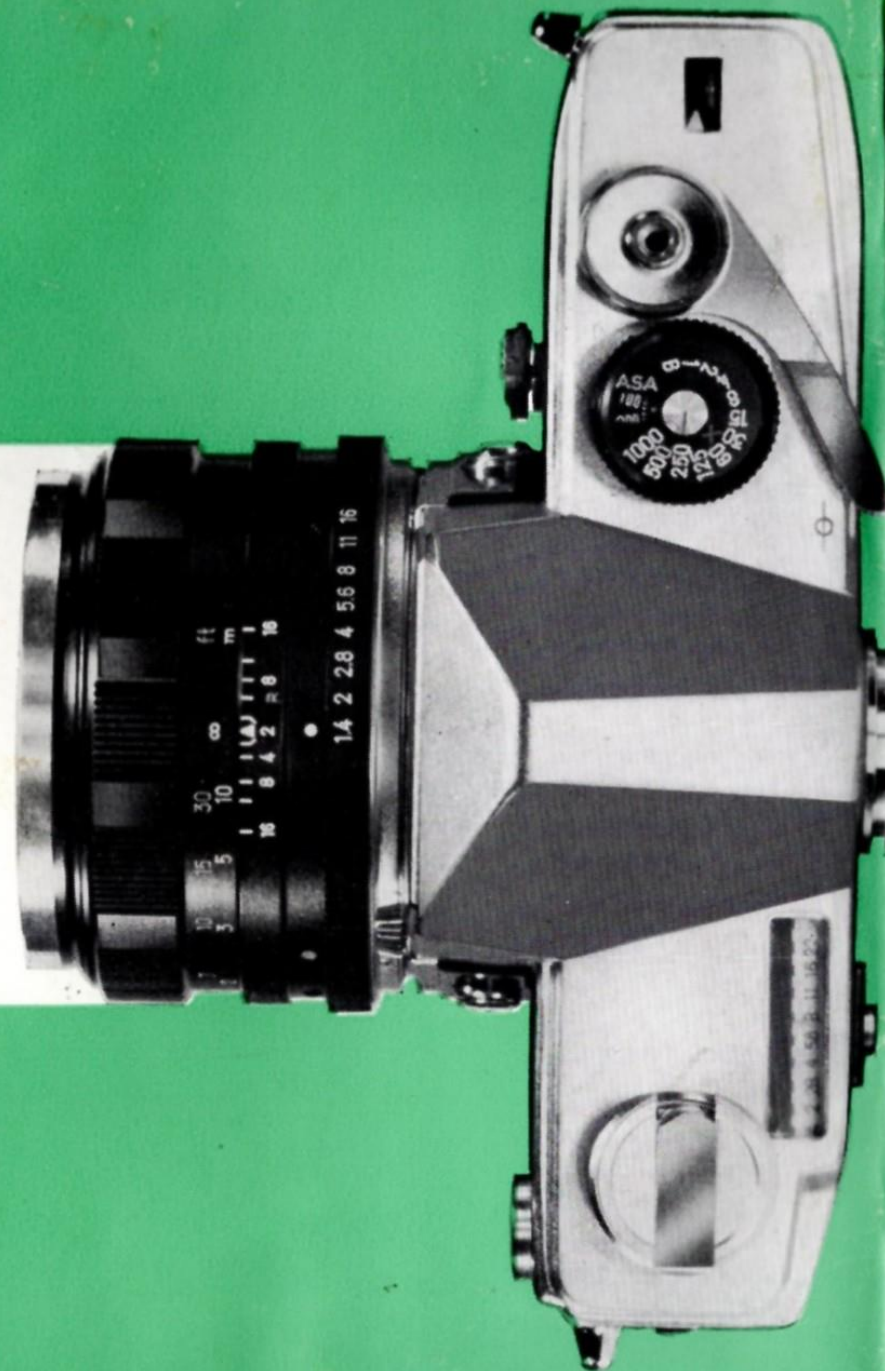

CONTENTS

Specifications	4, 5	Focusing and framing	28
6 Steps to perfect pictures	6, 7	Infrared film	29
Film loading	8, 9, 10	Holding the camera	30
Advancing film	11	Using slow shutter speeds	31
Shutter speeds.....	12	Unloading film	32, 33
Diaphragm setting	13	Setting the self-timer	34
Automatic diaphragm	14	Flash photography.....	35, 36, 37
Depth of field.....	15, 16	Mirror lock.....	38, 39
Depth of field pre-view	17, 18	Interchanging lenses	40
How to use CdS light meter	19 to 25	Accessories	42 to 57
Light meter battery	26, 27	Guarantee certificate.....	58

Minolta SR-7 Specifications

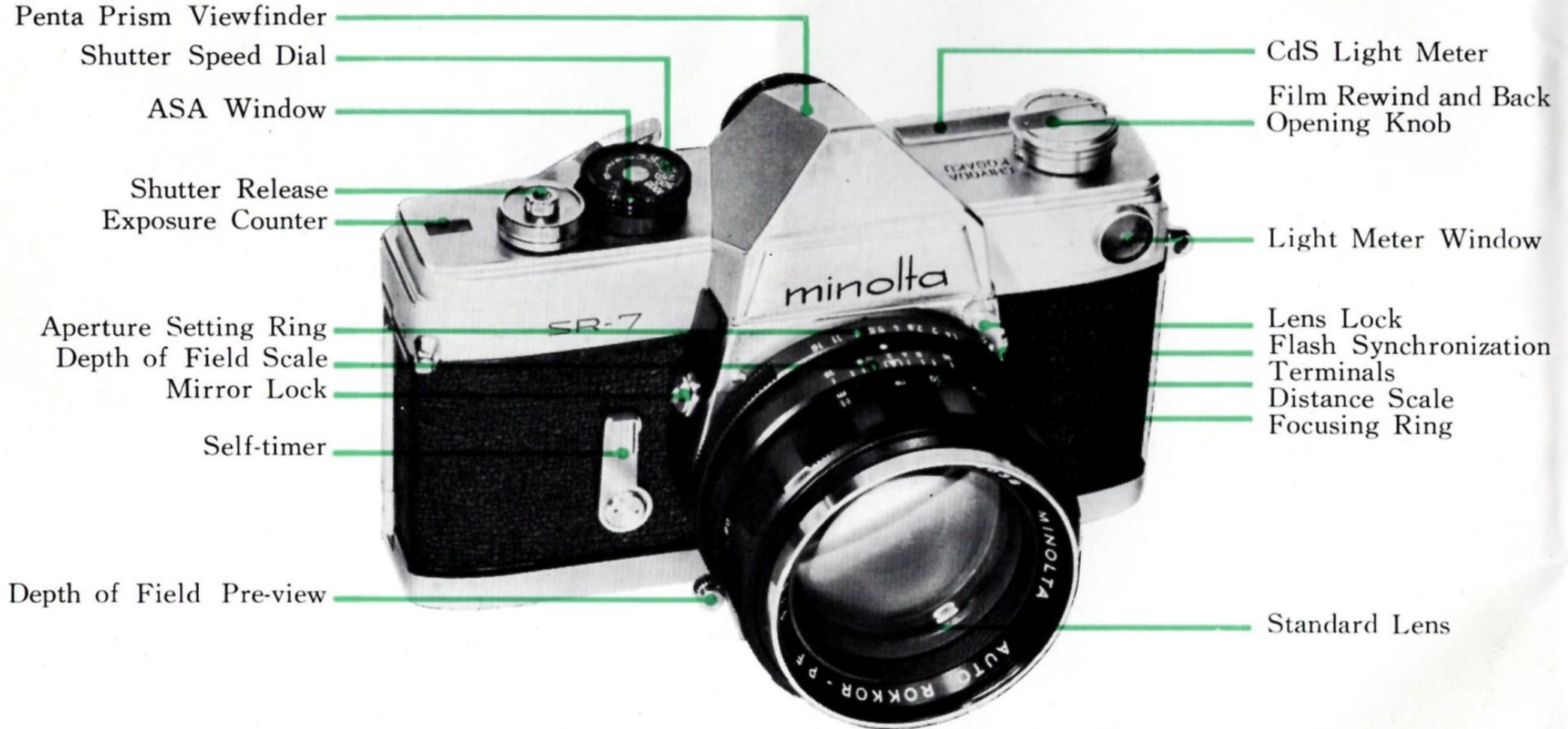

Film Pressure Plate
Take-up Spool
Sprocket Gear
Film Advance and
Shutter Cock
Viewer
High-Low Light Meter
Sensitivity Button
Shutter Curtain
Rewind Shaft
Tripod Socket

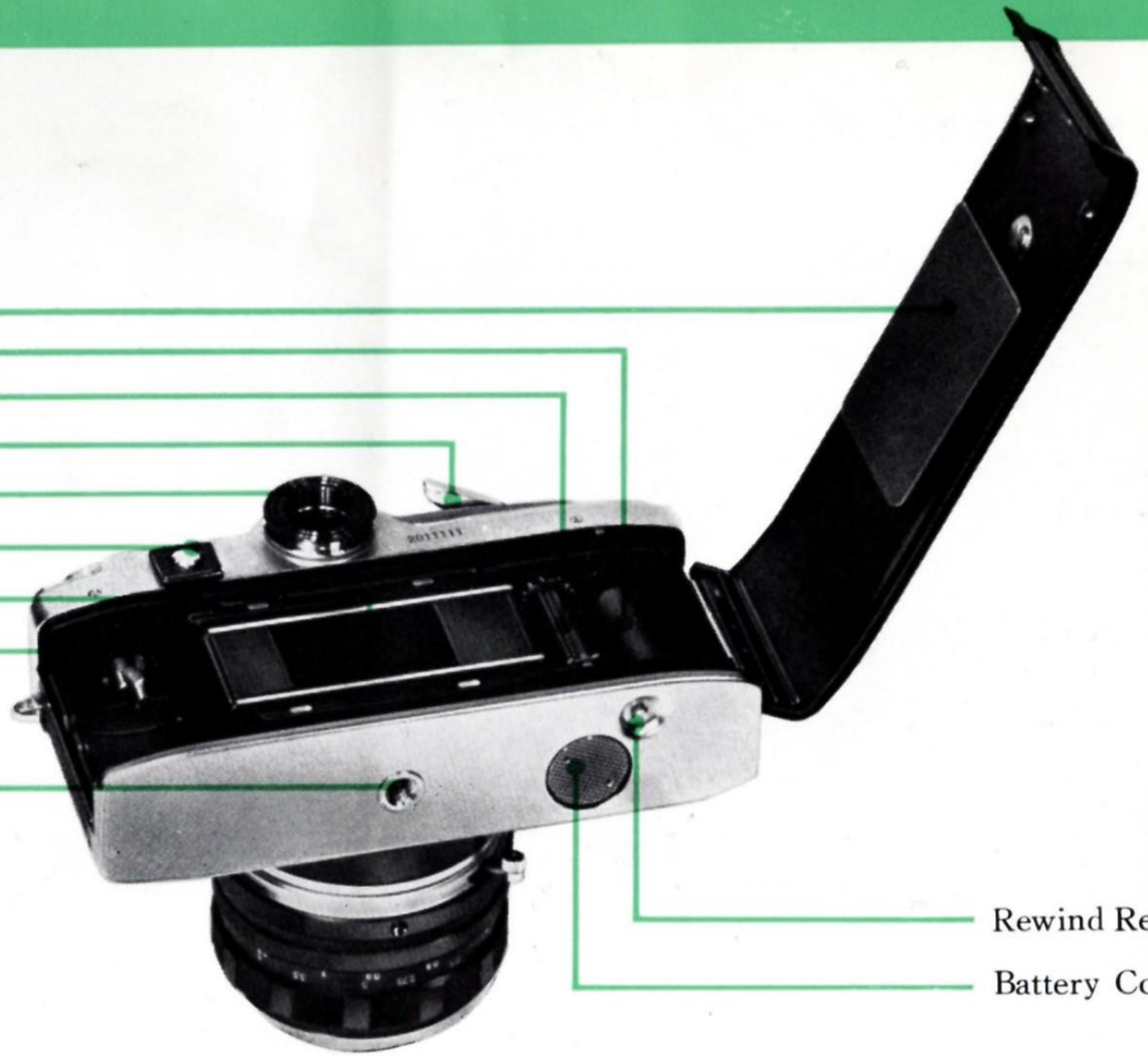

Rewind Release Button
Battery Cover



This manual is for reference and historical purposes, all rights reserved.

This page is copyright© by M. Butkus, NJ.

This page may not be sold or distributed without the expressed permission of the producer

I have no connection with any camera company

On-line camera manual library

This is the full text and images from the manual. This may take 3 full minutes for the PDF file to download.

If you find this manual useful, how about a donation of \$3 to: M. Butkus, 29 Lake Ave., High Bridge, NJ 08829-1701 and send your e-mail address so I can thank you. Most other places would charge you \$7.50 for a electronic copy or \$18.00 for a hard to read Xerox copy.

This will allow me to continue to buy new manuals and pay their shipping costs.

It'll make you feel better, won't it?

**If you use Pay Pal or wish to use your credit card,
click on the secure site on my main page.**

Donate: www.PayPal.me/butkus

venmo: @mike-butkus-camera Ph. 2083

6 steps to perfect pictures

1. Load film

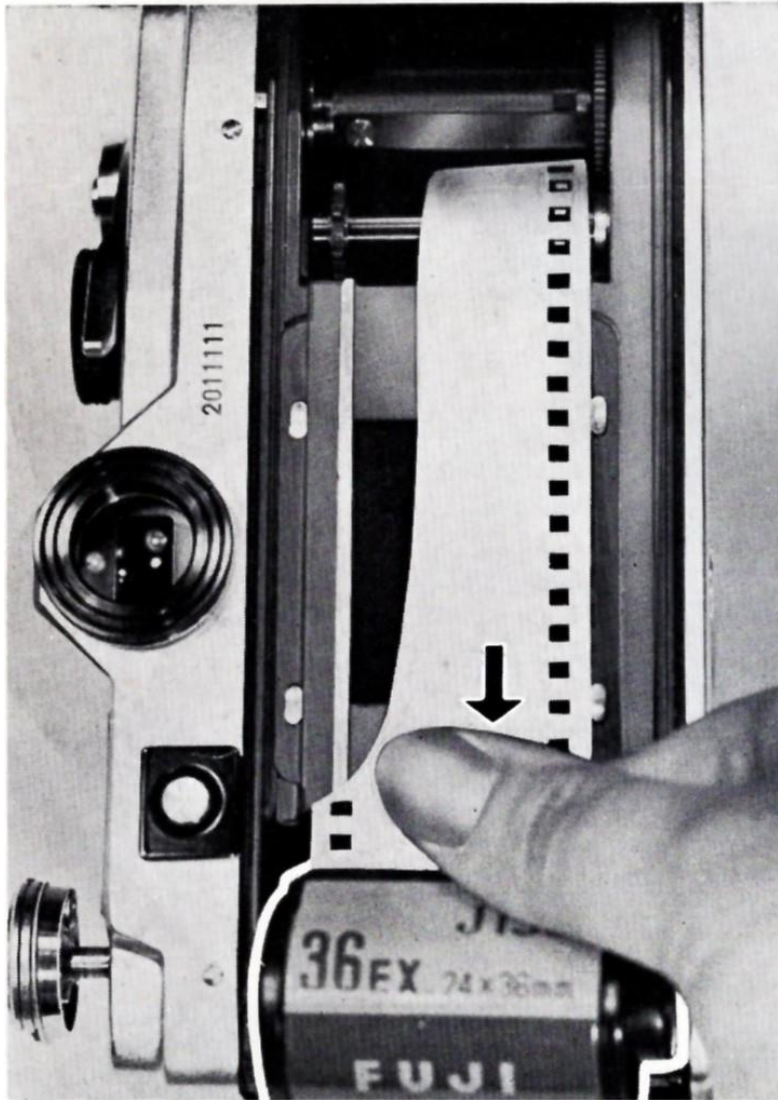

2. Advance lever

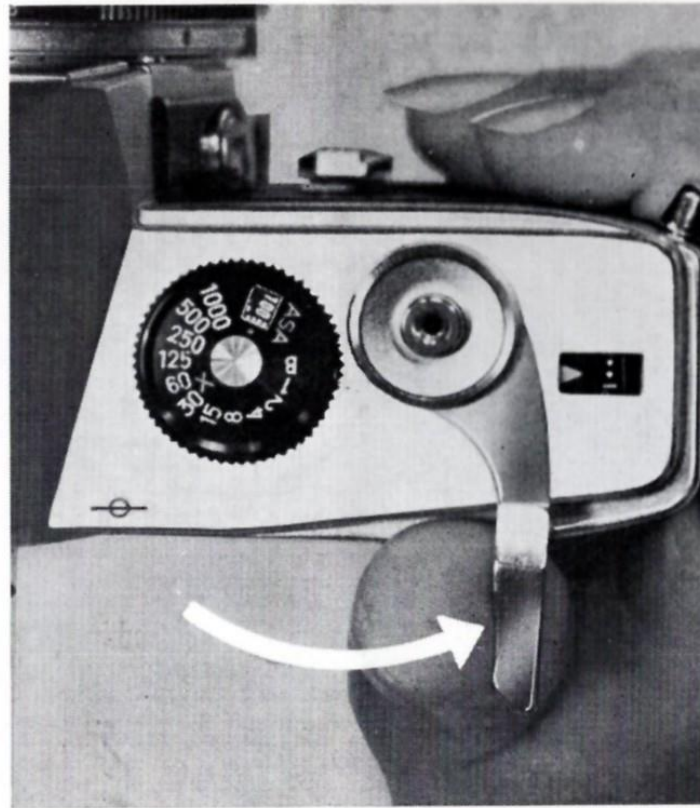

3. Set ASA film speed

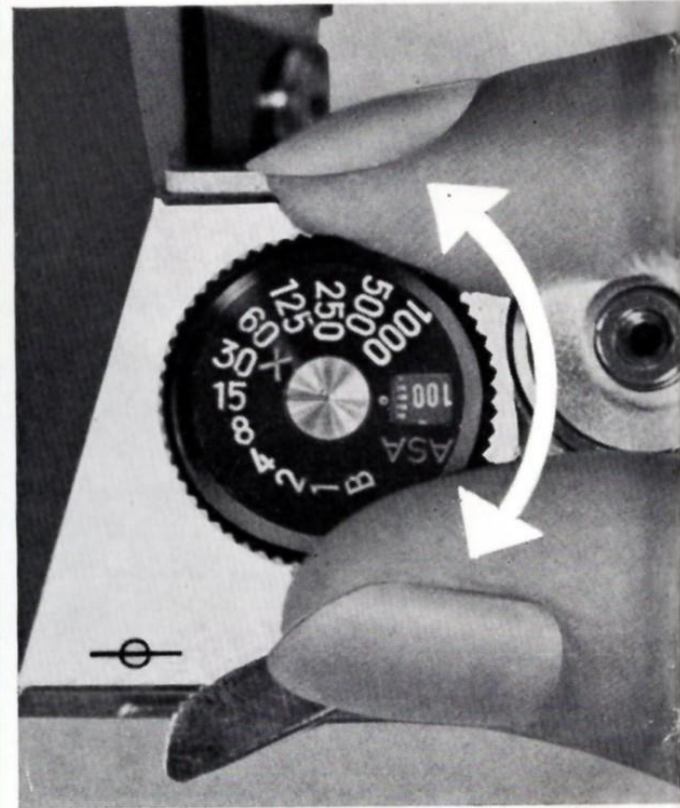

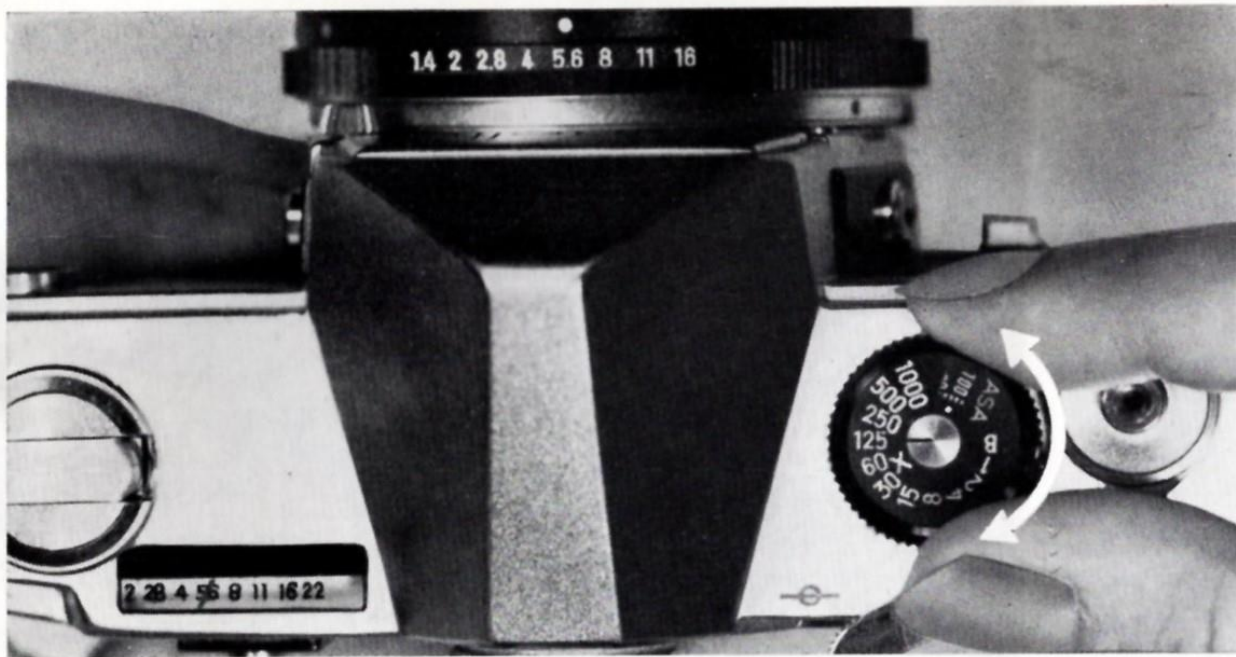

4. Set shutter speed



5. Measure exposure and set aperture

6. Focus and release shutter



(Each step is explained in detail on the following pages.)



Film loading

Use 35mm film-
20 or 36 exposure
roll.

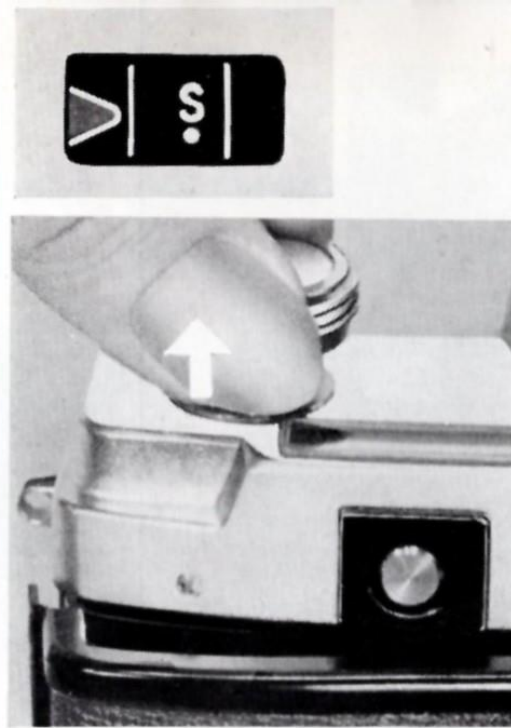

1.

To open the camera back, pull out the rewind knob until it stops. Then with a slight extra pull, the back will snap open. Exposure counter will automatically return to start position.

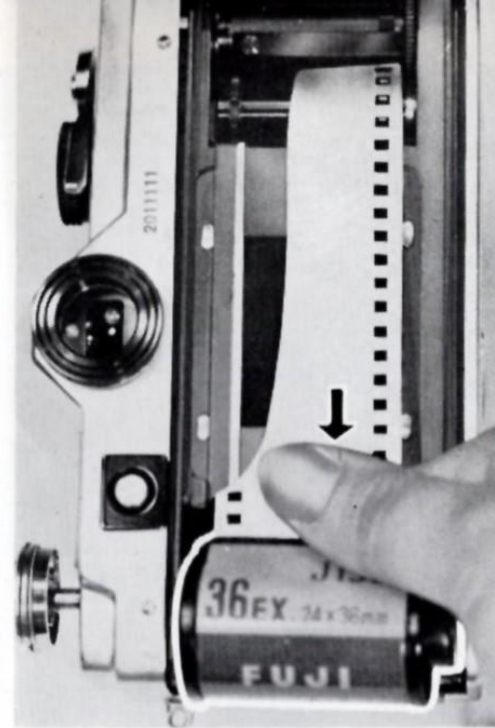

2.

Insert film magazine into the chamber so that the axis of the magazine is on the bottom side of the chamber.

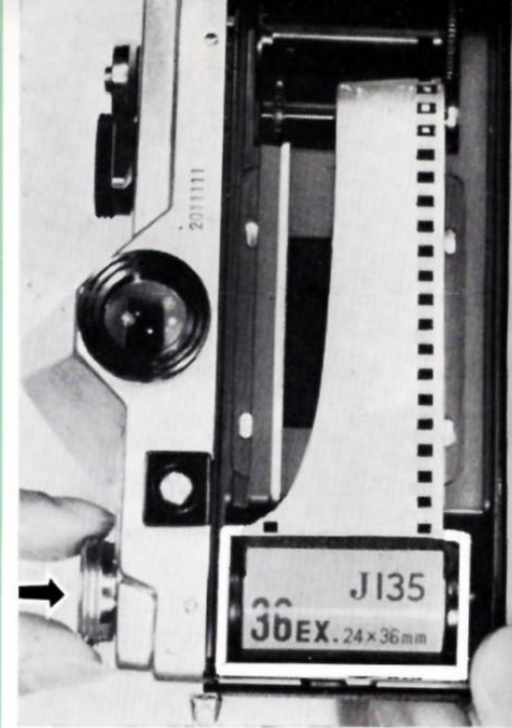

3.

Push the rewind knob down. If you should have any difficulty, turn the knob slightly and push down again.

4.

Turn the knurled base of the film take-up spool until the film catching clip faces upward.

5.

Insert the film leader into the take-up spool. Make sure the sprocket gear teeth are engaged with the film perforations.

6.

Advance the film lever until both sides of the film perforations are engaged properly with the sprocket gear. When the advance lever stops, release the shutter so you can advance further.

Film loading or unloading should be done in the shade. When loading the film, be sure not to touch the shutter curtain.

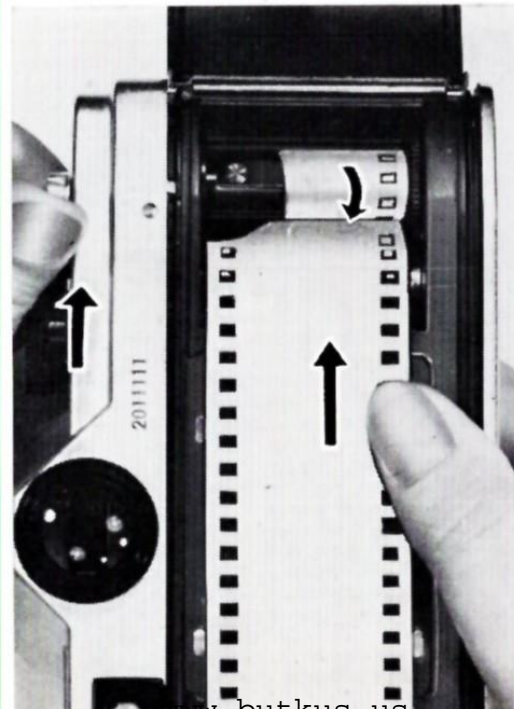
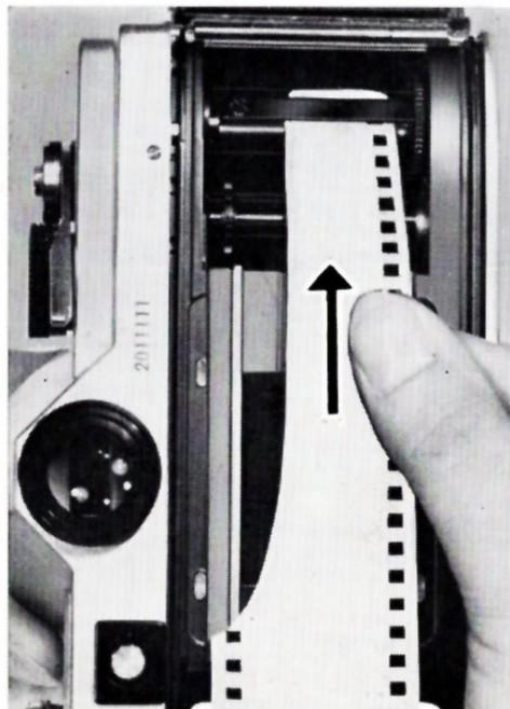
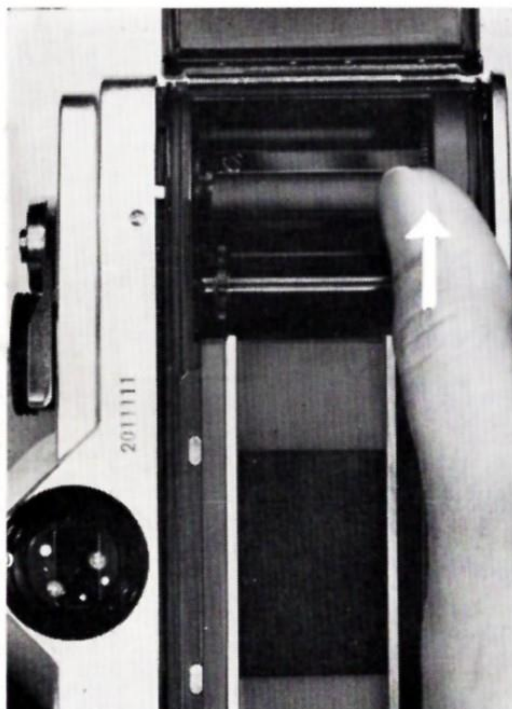

7.

Please make sure the film is parallel to the camera body before closing the camera back.



8.

Advance the lever until it stops and then release the shutter. Repeat this action twice and you are ready to shoot.

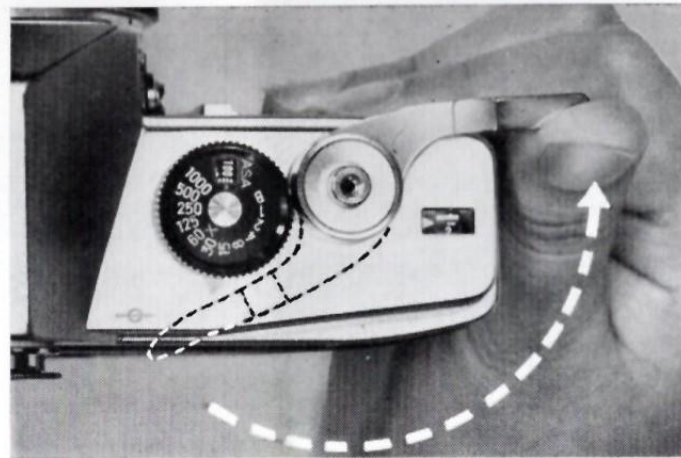

If the film is loose in the cartridge you can tighten it by turning the rewind knob clockwise.

9.

The film counter window indicates when the first film frame is in position ready to be exposed.

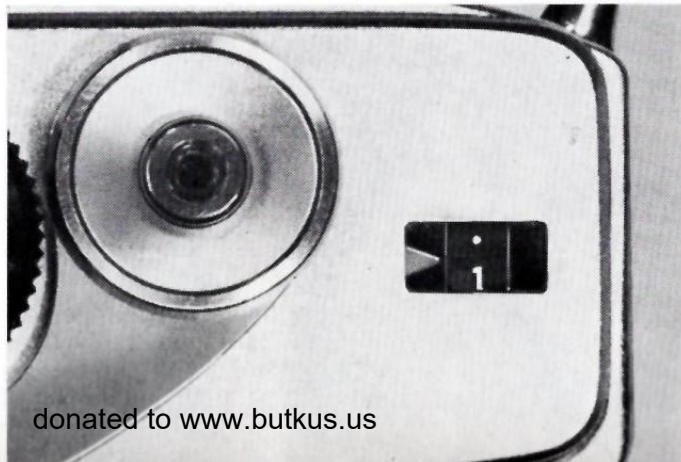



Advancing the film

The shutter cannot be released until the film advancing lever is completely wound. If, after advancing the lever, the shutter release is still locked, advance the lever again until it stops.

When winding the film advance lever, you will feel some resistance just before the end of the stroke. This is normal mechanical resistance. Keep winding until it stops completely.

Caution: At slow shutter speeds such as 1 second or 1/2 second, do not advance film while shutter is in motion.

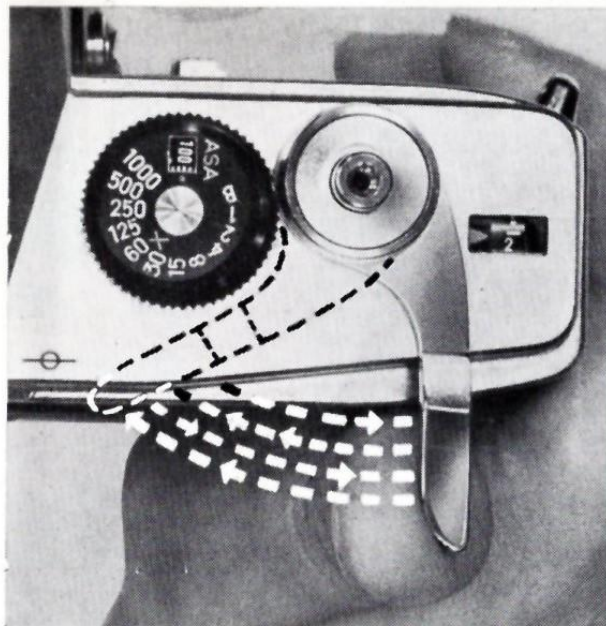

The film advance lever performs the following five actions simultaneously:

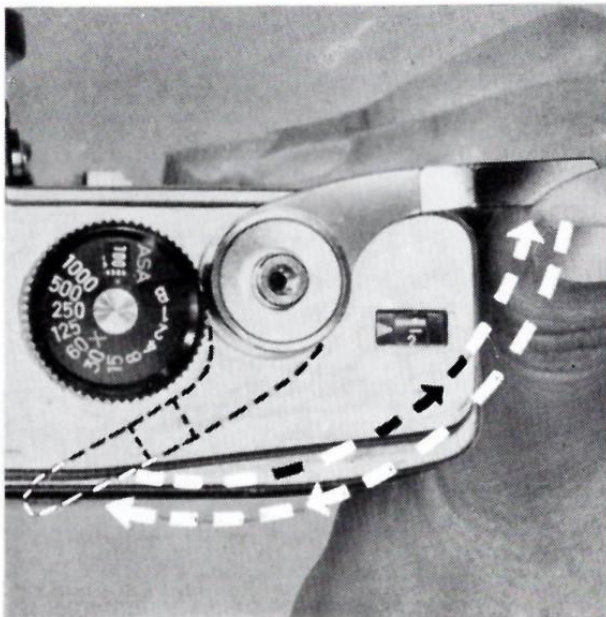

1. Advances the film
2. Advances the film counter
3. Cocks the shutter
4. Sets the quick return mirror
5. Opens the diaphragm fully

You can turn the lever either with several short strokes or one 180 degree stroke.

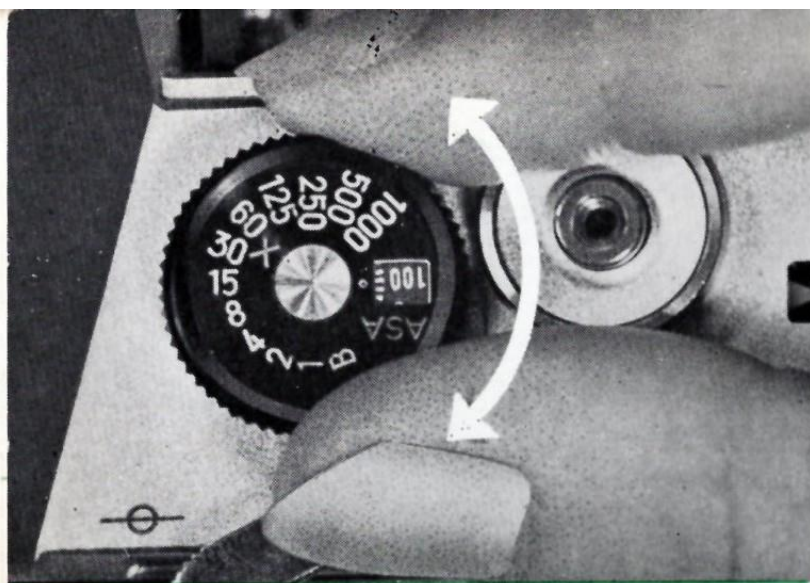

Setting the shutter

Turn the dial to the desired speed, lining it up with the center red line.

Intermediate speeds can also be set between any two figures. Dial can be turned in either direction and set either before or after advancing the lever.



Shutter speeds

The shutter speed dial is marked with figures 1 to 1000 plus B and X.

The figures 1, 2, 4, 8, 15, etc., indicate shutter speeds of 1 second, 1/2 second, 1/4 second up to 1/1000 second.

The B position, or bulb, enables you to keep the shutter open as long as the shutter button is pressed down. This position is used when more than one second exposure is required.

The X position corresponds to about 1/50 second speed. This speed is used with electronic flash equipment.



Setting the diaphragm

The diaphragm ring has aperture figures from 1.4 to 16. Turn the diaphragm ring so that the desired aperture figure coincides with the white dot.

The click stops enable you to use intermediate aperture openings between any two f/stops. The larger the aperture figure, the less light volume is permitted through the lens. For example, at $f/16$ the diaphragm is closed down to a pin-point opening; at $f/1.4$ it is wide open. The relationship between aperture and light volume is shown on the scale above.

Diaphragm can be set either before or after advancing the film lever.

Apertrue	1.4	2	2.8	4	5.6	8	11	16
Light volume								
	2	1	1/2	1/4	1/8	1/16	1/32	1/64



What is a completely automatic pre-set diaphragm?

One of the superb features of the Minolta SR-7 is its completely automatic pre-set diaphragm. In a conventional single lens reflex camera, when the lens is stopped down the visual field of view becomes darker thus making it difficult to focus.

In the Minolta SR-7, the lens is completely automatic and pre-set; aperture is always at maximum opening until the shutter is released. Consequently, focusing can be quickly determined through the extra bright viewfinder no matter what aperture you have pre-selected.

When the shutter is released, the diaphragm closes to pre-set aperture, the mirror clears, the picture is taken, the mirror returns, the diaphragm re-opens to maximum aperture... all simultaneously, all automatically.

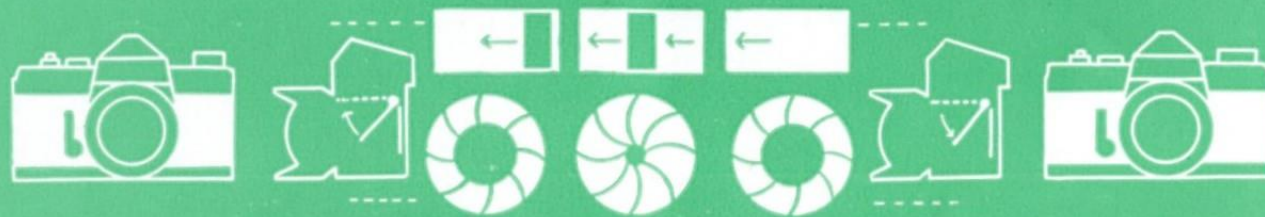



Depth of field



The depth of field of a lens is the range of distance within which all subjects are in relatively sharp focus. This range varies with the aperture opening. It is greatest when the lens is stopped down (f16) and least when it is fully open (f1.4). The photographs above illustrate relationship. The same subject was taken at different aperture settings.

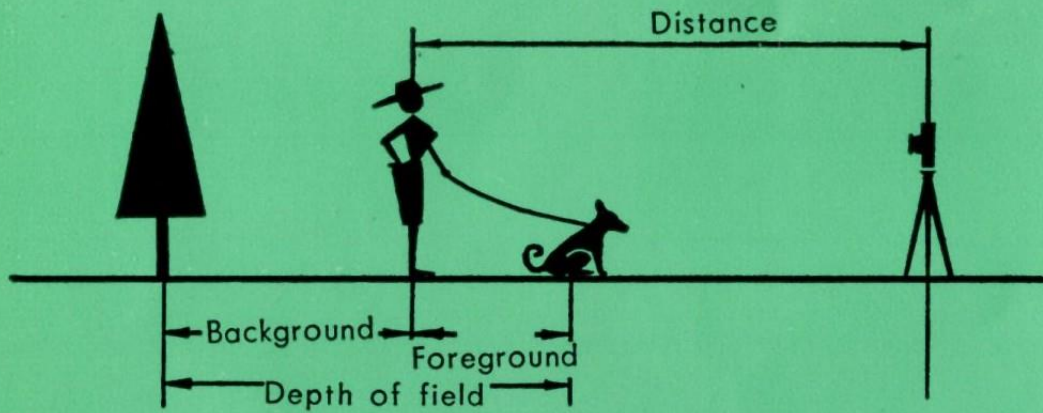

The principles governing depth of field

1. The depth of field is greater as the distance is increased or the aperture is stopped down.
2. The depth of field grows less as the distance is decreased or the aperture is enlarged.
3. The depth extends greater into the background than into the foreground.
4. The depth of field is greater with a shorter focal length lens and shallower with a longer focal length lens.

Because the depth of field can be controlled by the aperture stops, you can either bring to sharpness both background and foreground or emphasize the subject sharpness only by purposely making the background out of focus.

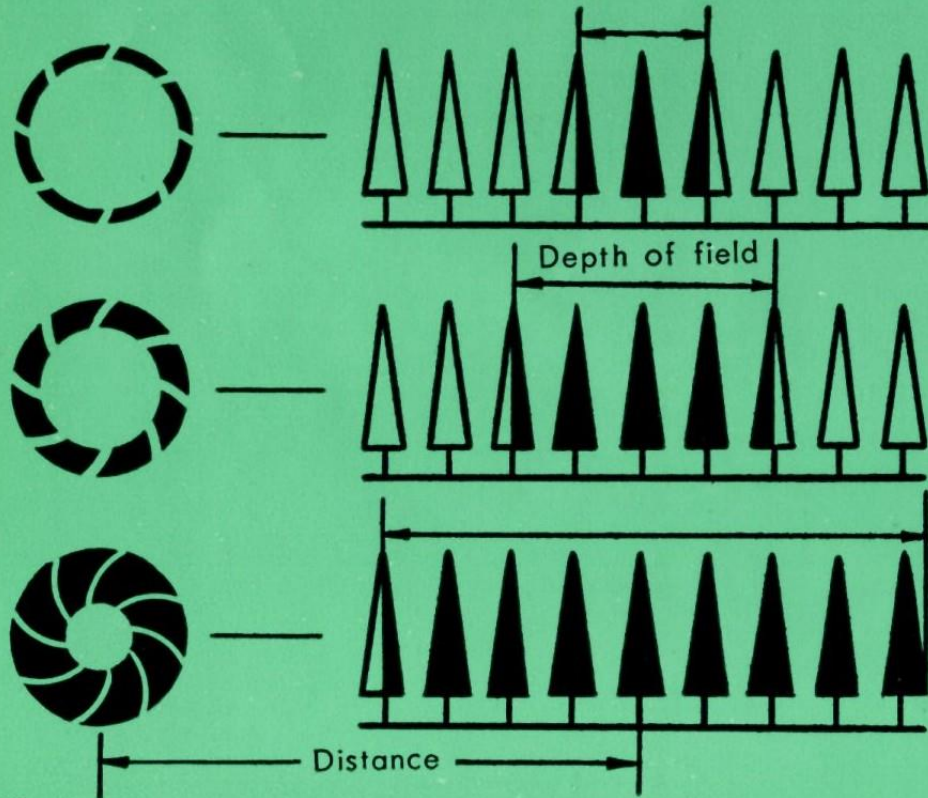

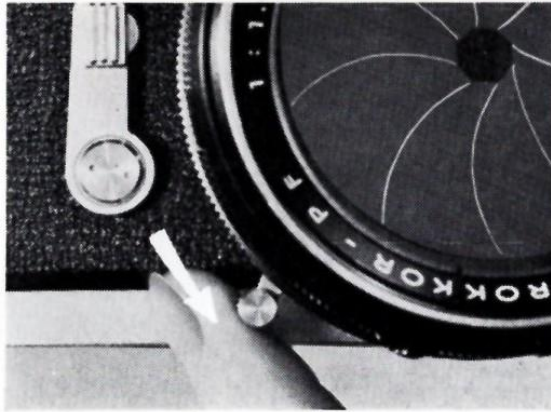

Depth of field pre-view

You may pre-view depth of field, if you wish, by pressing the pre-view button which manually closes the diaphragm to its pre-set aperture. When you do this you can inspect through the viewer the precise effect of depth of field.

Depth of field scale

You can also check depth of field by referring to the depth of field scale marked on the lens barrel. This indicates in feet and meters the range within which everything will be in focus.

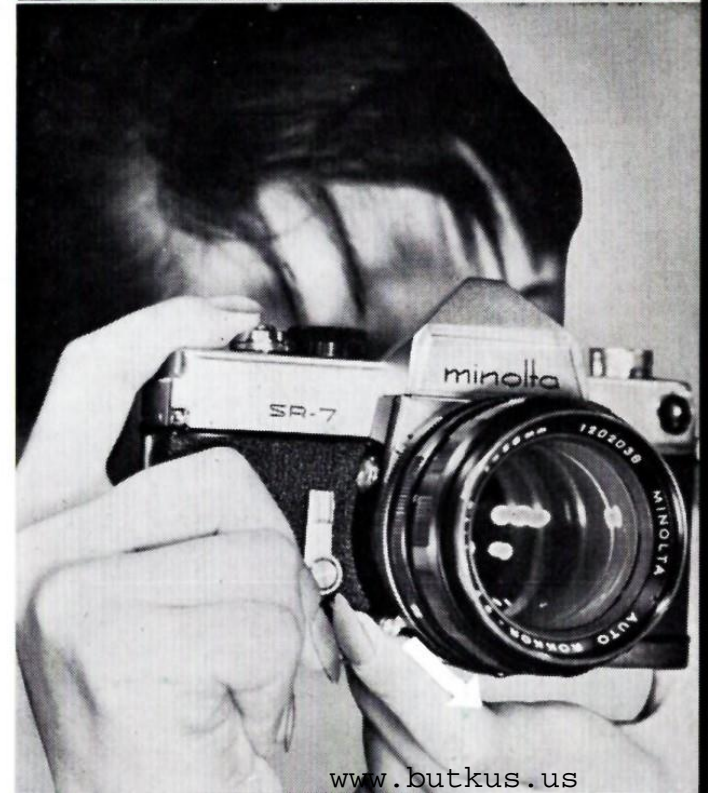

Depth of field table

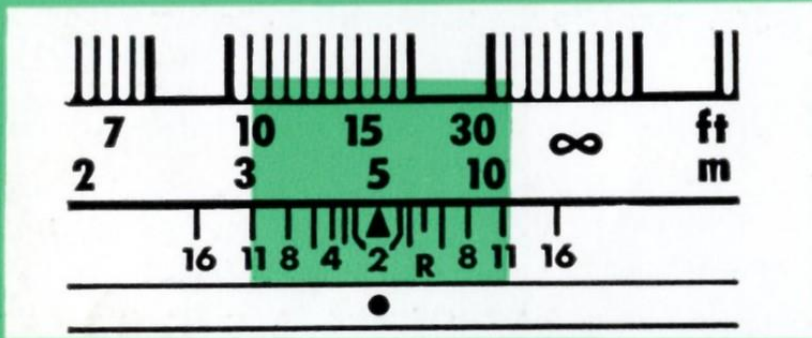

The arrow mark ▲ on the scale indicates the distance between camera and focused subject. The two sets of figures on both sides of the arrow mark are aperture stops and the distance framed by the two same figures shows the depth of field. For example, if you focus on a subject 15 feet away and use an f11 aperture, read the distance opposite the two figures 11. In this case the depth of field is approximately 10 feet to 37 feet. Within that distance range all subjects are in relatively sharp focus.

Auto Rokkor 58mm/f1.4

F No, Dis- tance Ft,	1.4	2	2.8	4	5.6	8	11	16
∞	243.50 ∞	176.59 ∞	124.92 ∞	88.38 ∞	62.54 ∞	44.27 ∞	31.35 ∞	22.22 ∞
60	47.97 80.12	44.88 90.55	40.65 114.80	35.86 184.88	30.75 1362.85	25.60 ∞	20.71 ∞	16.32 ∞
30	26.68 34.26	25.71 36.02	24.27 39.30	22.50 45.10	20.39 57.01	18.01 91.11	15.46 600.58	12.89 ∞
15	14.14 16.07	13.87 16.34	13.44 16.97	12.92 17.95	12.18 19.55	11.30 22.37	10.26 28.12	9.08 44.27
10	9.62 10.42	9.49 10.57	9.29 10.82	9.17 11.00	8.68 11.79	8.24 12.75	7.68 14.40	7.01 17.63
7	6.81 7.20	6.75 7.27	6.65 7.38	6.52 7.56	6.34 7.81	6.11 8.21	5.80 11.19	5.42 9.94
5	4.91 5.10	4.88 5.13	4.83 5.19	4.76 5.27	4.67 5.39	4.54 5.57	4.38 5.84	4.16 6.28
4	3.94 4.06	3.92 4.08	3.89 4.11	3.85 4.16	3.79 4.24	3.71 4.34	3.60 4.50	3.46 4.75
3.5	3.46 3.54	3.44 3.56	3.42 3.59	3.39 3.62	3.34 3.67	3.28 3.75	3.20 3.87	3.09 4.05
3	2.97 3.03	2.96 3.04	2.94 3.06	2.91 3.09	2.89 3.12	2.84 3.18	2.78 3.26	2.70 3.38
2.75	2.72 2.78	2.72 2.79	2.70 2.80	2.68 2.83	2.65 2.86	2.61 2.91	2.57 2.96	2.50 3.06
2.5	2.48 2.52	2.47 2.53	2.46 2.54	2.44 2.56	2.41 2.60	2.39 2.63	2.35 2.67	2.30 2.75
2.25	2.23 2.27	2.23 2.27	2.22 2.28	2.20 2.30	2.18 2.32	2.16 2.35	2.13 2.38	2.09 2.44
2	1.99 2.01	1.98 2.02	1.98 2.02	1.96 2.04	1.95 2.05	1.93 2.08	1.91 2.10	1.88 2.14



Highly accurate CdS light meter

Your Minolta SR-7 is the world's first single lens reflex camera with a built-in CdS light meter. It's powered by a mercury battery and extremely sensitive, covers an extensive range from candlelight to bright outdoors (0.28-18,000 Cd/m²). The light receiving angle is only 30°. Hence, you measure the light reflected by the subject only. Extraneous light does not upset exposure readings. The meter is coupled to the shutter and, as you will read on the following pages, very easy to use.

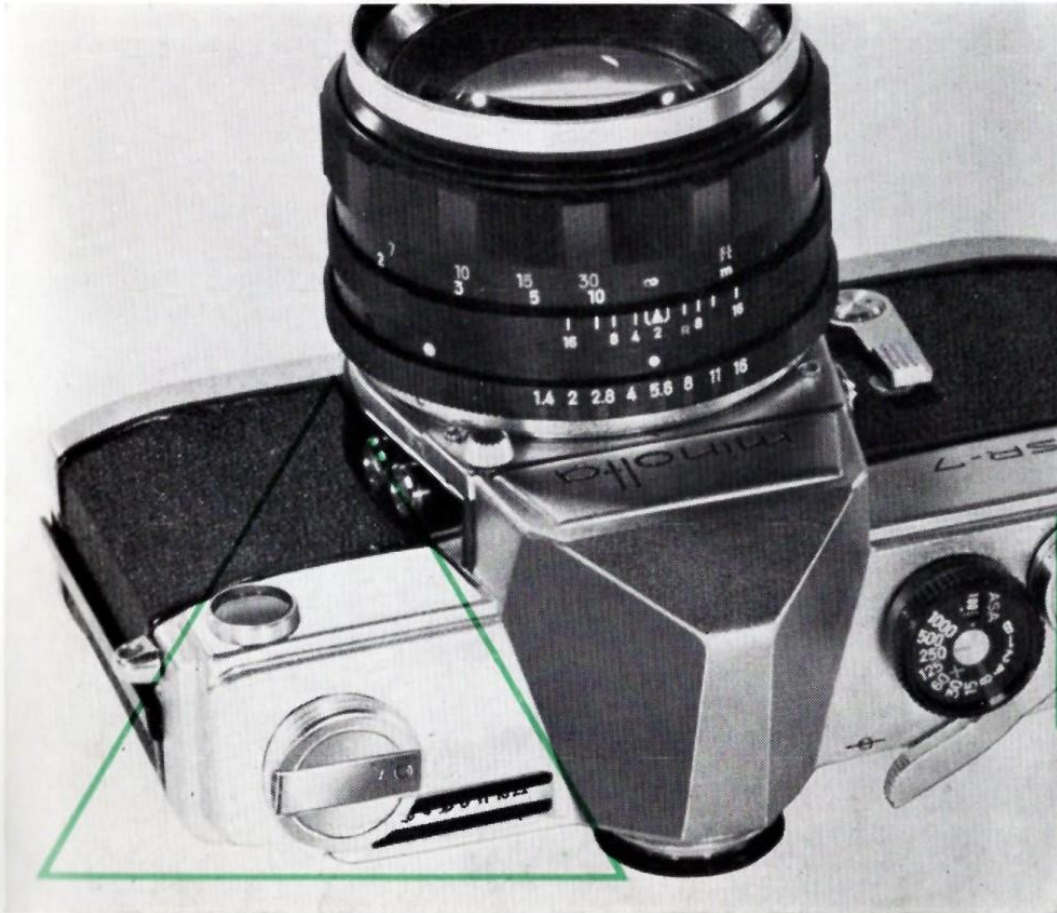

Aperture (F:)	1.4	2	2.8	4	5.6	8	11	16				
Shutter Speed (sec.)	1/1000	1/500	1/250	1/125	1/60	1/30	1/15	1/8	1/4	1/2	1	B

Table shows relationship between aperture and shutter speeds.

How to use the CdS light meter

Used correctly, the CdS light meter will give you correct exposure every time. It measures outdoor light and indoor light as well. It's extremely versatile. If the meter needle reads off the scale; does not indicate aperture, shift to a lower shutter speed. If no aperture is indicated, shift to low sensitivity light. If the meter still does not respond, then light is inadequate for exposure and you must use flash.

Immediately after loading film, set the ASA film speed rating on the shutter dial. Pull the outer ring of the dial upwards and rotate to the ASA rating of the film you are using. This action sets the meter in tune with the speed of your film.

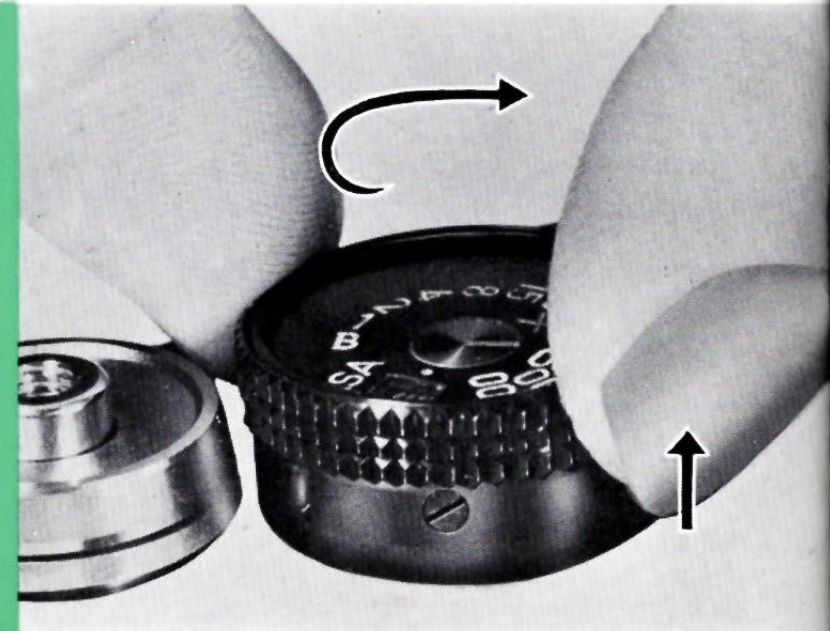



Film speed chart

Films	A S A
ILFORD HPS	400
AnSCO Super Hypan	500
ADOX KB 14	(DIN) 14
ADOX KB 17	(DIN) 17
ADOX KB 21	(DIN) 21
Kodak Panatomic X	25
Kodak Plus X	80
Kodak Tri X	200
Kodacolor	32
Ektachrome (daylight type)	32
Kodachrome (daylight type)	10
Super Anscochrome (daylight type)	100
Anscochrome	32

Emulsion speed numbers (ASA) are listed above for your convenience. They are also found on the instruction sheet contained with each film.



Selecting shutter speed or aperture

You may set either shutter speed or aperture first. If you set shutter speed first, the meter needle will indicate the correct aperture for that speed. If you set aperture first, adjust the shutter dial, while measuring the light, until the meter needle coincides with the aperture you have pre-selected.

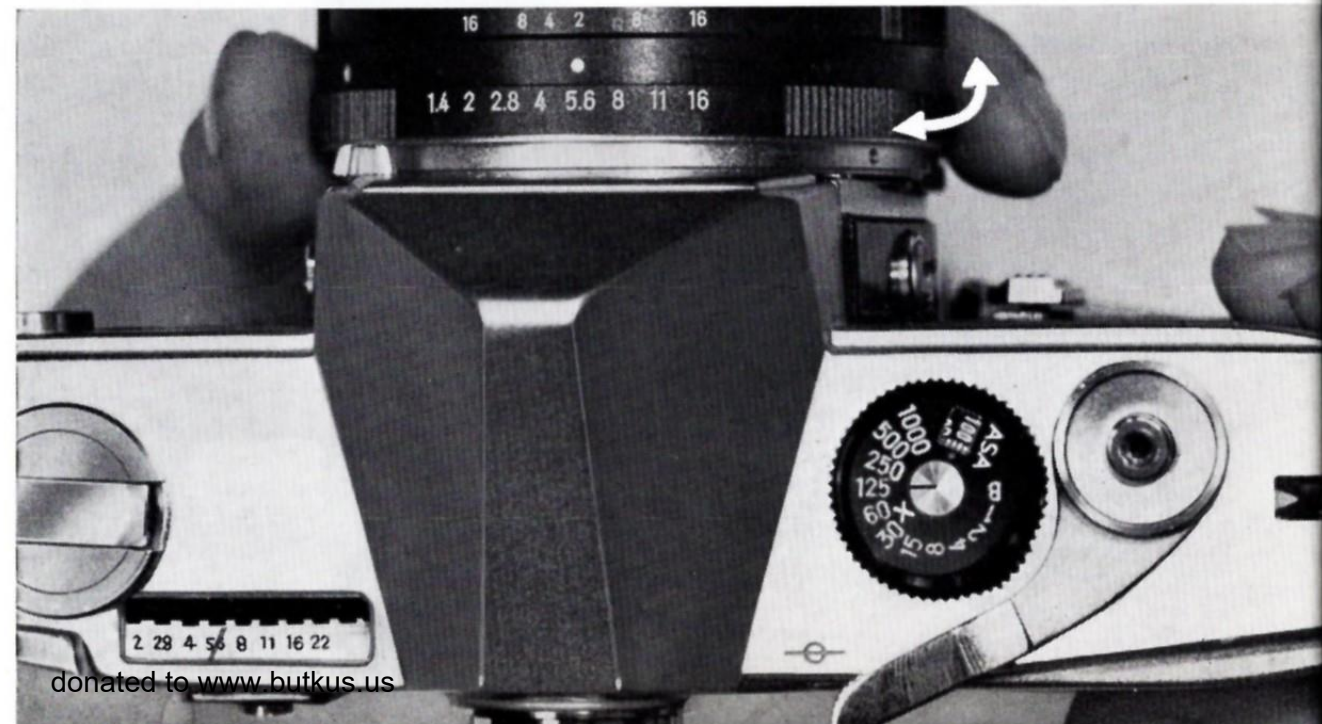
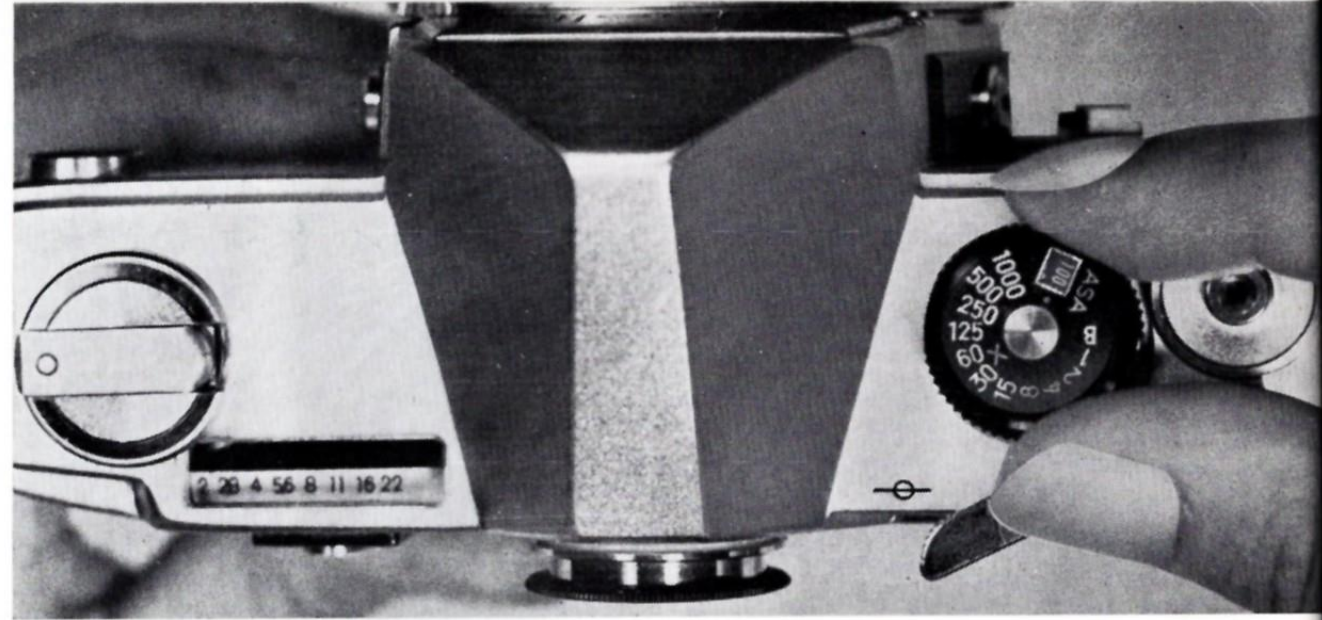



Shutter speed is usually determined by the motion of the subject. If you are compelled to use a fast shutter speed, 1/500 for example, set it on the shutter dial. The dial is

1/500 sec. for fast moving objects.

1/125 sec. for slow moving objects.

1/30 sec. or slower in dark places.

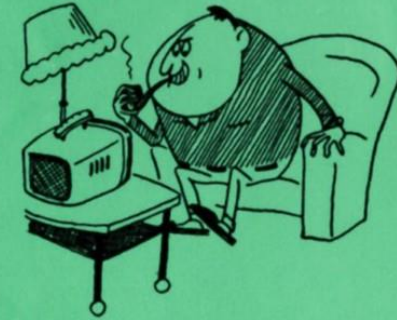
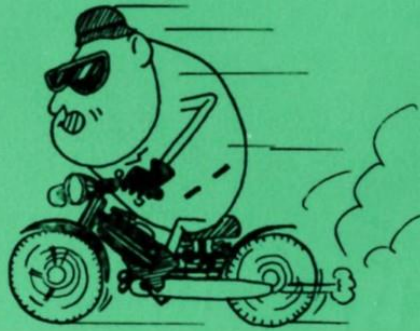

coupled to the meter and automatically adjusts the meter's light value scale to coincide with the shutter speeds. In other words, the meter will indicate correct aperture for any one of a variety of shutter speeds.

Reading the meter

When determining aperture setting, read along the dotted line of the light value scale. The meter needle will indicate the correct diaphragm opening. It will not, however, always point directly to a f/stop number. It may fall between two dotted lines in which case an intermediate f/stop should be set on the aperture ring of the lens barrel.

Low sensitivity switch

When the meter needle does not register due to inadequate light, use the low sensitivity shift button. Press the button on the back of the meter.

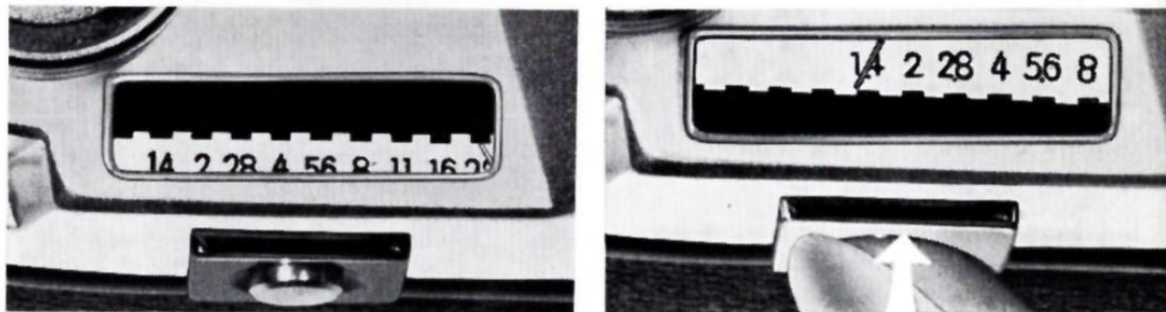

This shifts the meter to low sensitivity light and gives a correct exposure reading even under adverse lighting conditions.



In some cases the low sensitivity reading may be one f/stop lower than the high sensitivity reading. Use the lower light

value

Determining reflected light

Photographing People

When photographing a person, the light reflected by the subject and the light reflected by the background may be at wide variance, particularly in snow, at the beach or in other bright backgrounds. In such cases move the camera close to the subject and measure the reflected light. If you cannot approach the subject, light can be measured by extending the palm of your hand in front of the meter.



Backlighting

In the case of backlighting, move close to the subject and measure the light reflected from it. Be particularly careful that the back light does not strike the light-receiving surface of the exposure meter. Otherwise the result will be a silhouette.

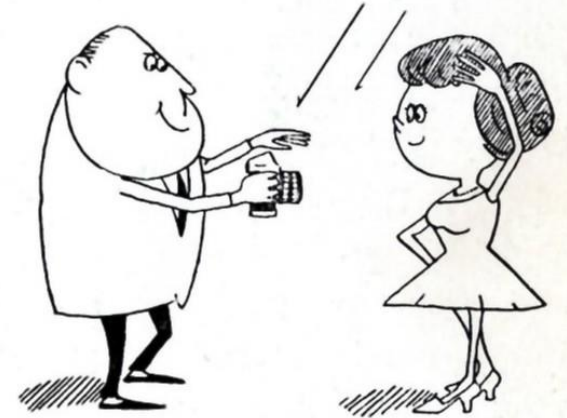

Landscape Photographing

For landscape photographing, the subject, of course, cannot be approached and exposure must be measured at the camera position. Special care should be taken so that direct light from the sky is not measured. Measure the general lighting conditions of the area and take the average reading.



Your CdS light meter is powered by a mercury battery. Unlike conventional batteries, the mercury battery does not lose power gradually. When it dies, it dies abruptly. Hence your light meter is always working at maximum accuracy.

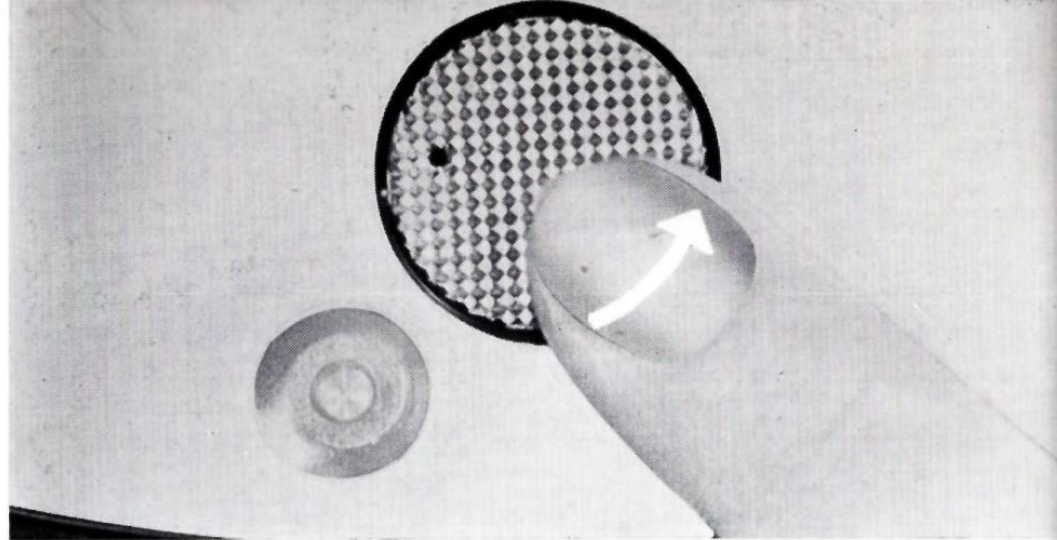

Replacing the battery

The average life of the mercury battery is two years. When the meter does not respond to light, the battery is dead and must be replaced. This is a conventional mercury battery available throughout the world.

Remove the battery cover on the bottom of the camera by turning the cover with your thumb counter-clockwise. Take out the old battery. When replacing the new battery, be sure the plus (+) side is facing up towards you.

“Caution in handling the mercury battery”

Do not leave finger prints on the mercury battery as these cause it to rust or corrode. Wipe with a soft cloth and keep battery clean. Do not disassemble the mercury battery. Do not throw any used mercury battery into a fire or where children can get hold of it.

If the camera is left unused for a long period of time, it is advisable to remove the battery to insure longer life.

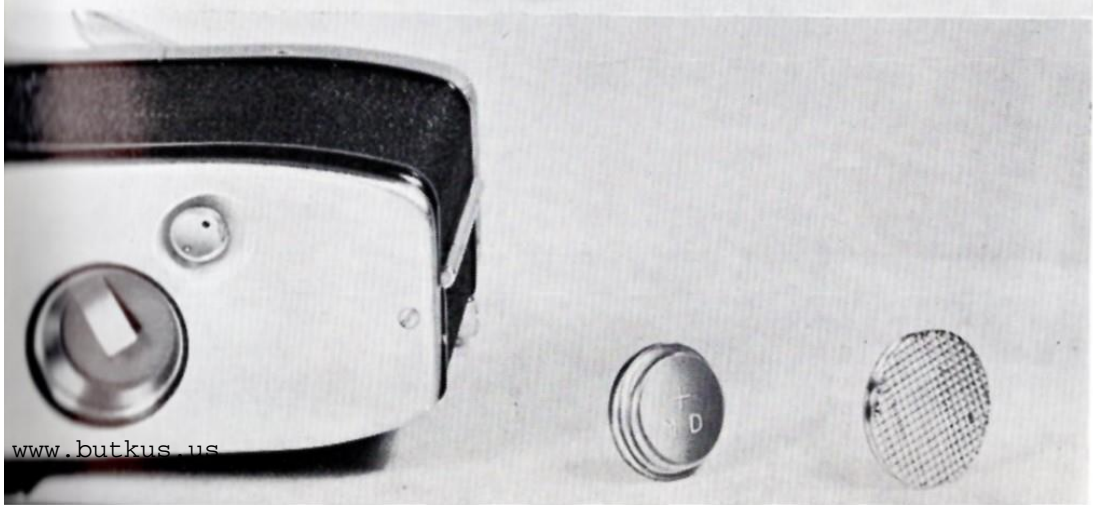
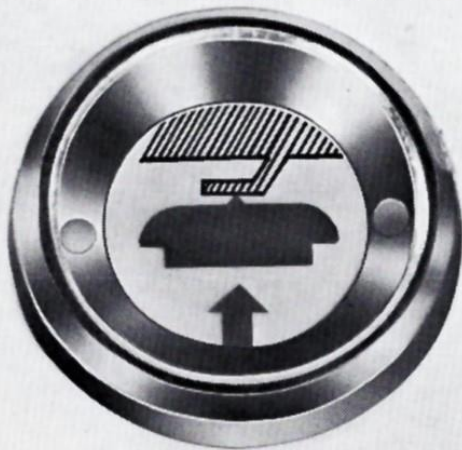
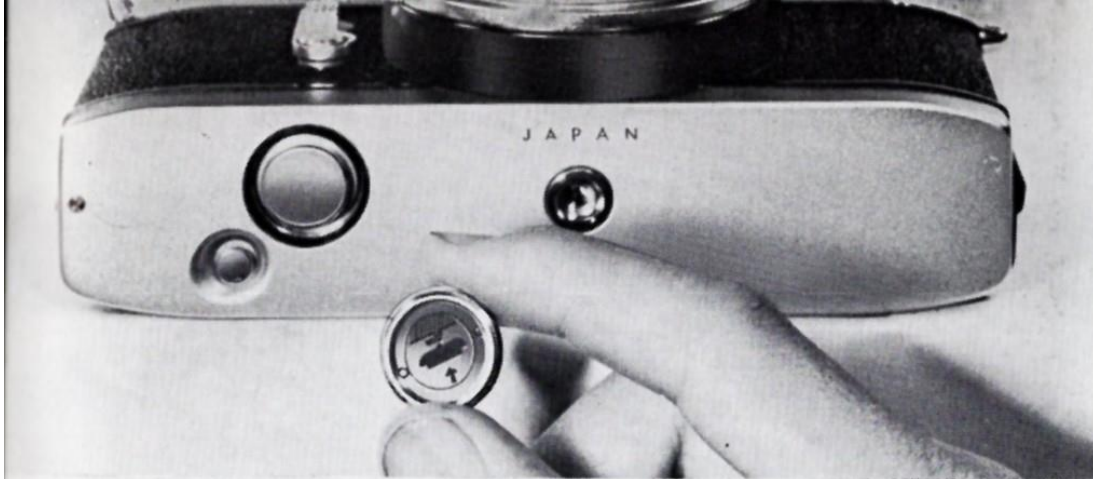

Emulsion speed indicator

As a convenient reminder, set the indicator located on the back of the camera to the emulsion speed number (ASA or DIN) of the film you have just loaded. Simply turn the dial to the corresponding number of your film speed. For color film use the red figures.



Focusing and framing

Look through the viewfinder and rotate the focusing ring on the lens barrel. Your subject will become sharp and clear. At the sharpest point you are in focus and ready to shoot. You see exactly the same image that will appear on the film negative. This is one of the advantages of the single lens reflex system. More important, because you focus through the lens there is never a parallax problem no matter how close you get to the subject. This system also permits you to see the real relationship between subject, background and foreground and the actual color condition when using filters.



Infrared film indicator

If you use infrared film, focus as you would ordinarily. Then move the distance scale to correspond with the red letter R which appears on the depth of field scale. For example, if your focus scale tells you the subject is 15 feet from the camera, move the focusing ring so that the number 15 lines up with the red letter R

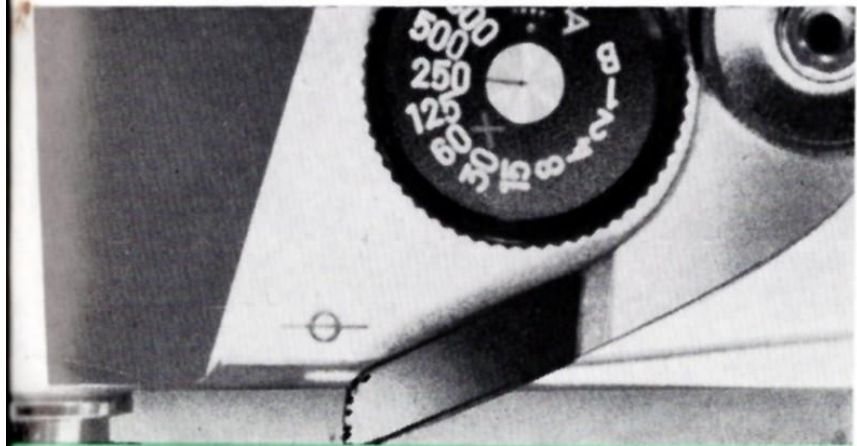

Film position indicator

On the top of the camera there is a red circle with a line through it. This mark indicates the exact position of the film in the camera. Precise distance then is the distance from the subject to this line. With the aid of a tape measure, this line can be used for extremely critical focusing. For general photography such focusing is not necessary.

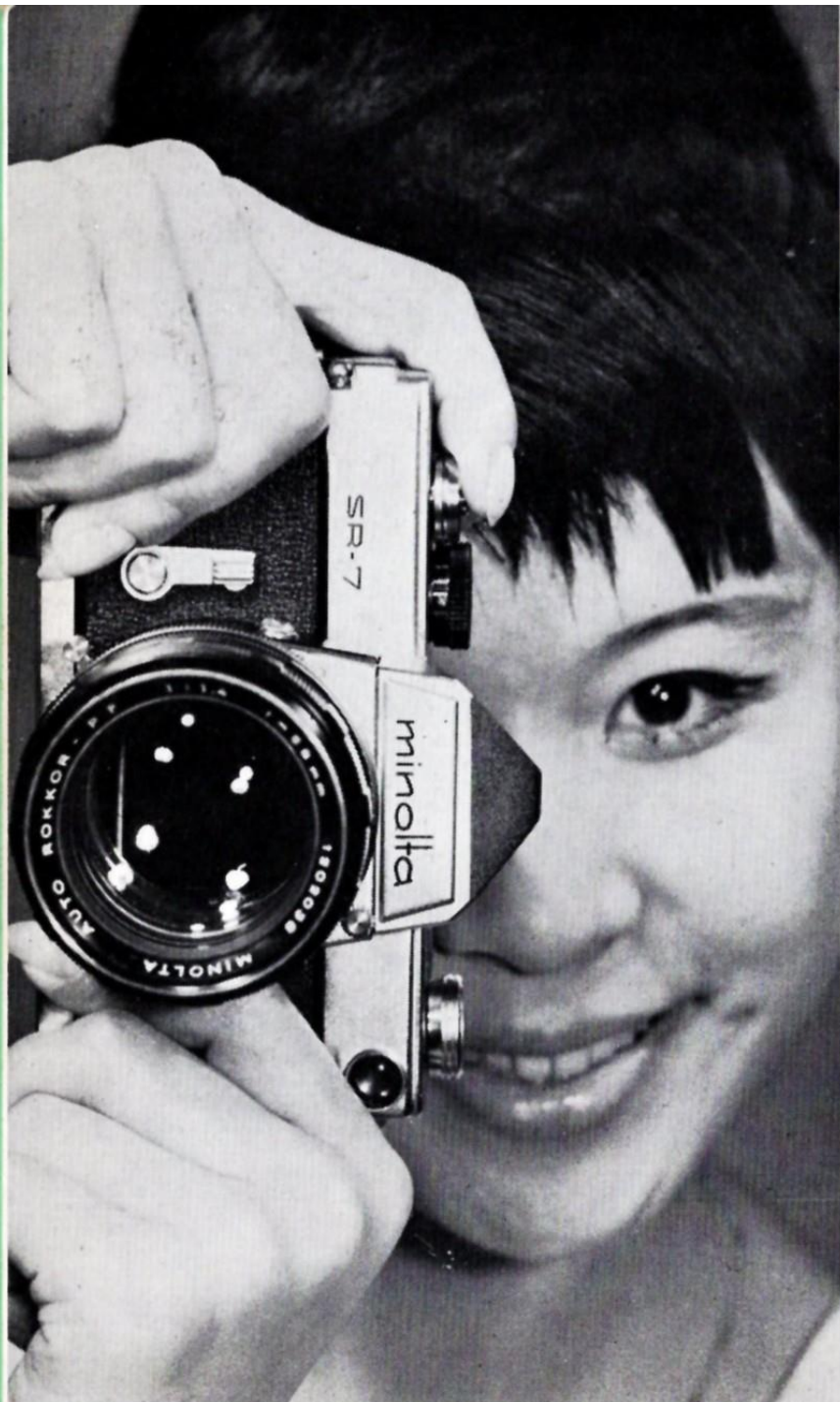

Holding the camera—Releasing the shutter

The camera may be held horizontally or vertically. It is best to press the camera firmly against your face and release the shutter with a slow pressure in order to avoid all movements and insure sharp negatives. You may focus with whichever eye is convenient for you, although for sequence shots it is advisable to use the right eye to permit free use of the rapid wind lever. The lever contains a double exposure prevention device; the shutter locks after each picture.

Using slow shutter speeds

When using shutter speeds of 1/15 second or slower it is advisable to use a tripod and cable release to avoid all camera movement. If a tripod is not available, set the camera on or against something stationary. The cable release is screwed into the shutter release button. It is best to use a cable release whenever you use a tripod.

Note: At slow shutter speeds please be careful not to advance the film while the shutter mechanism is still in motion.

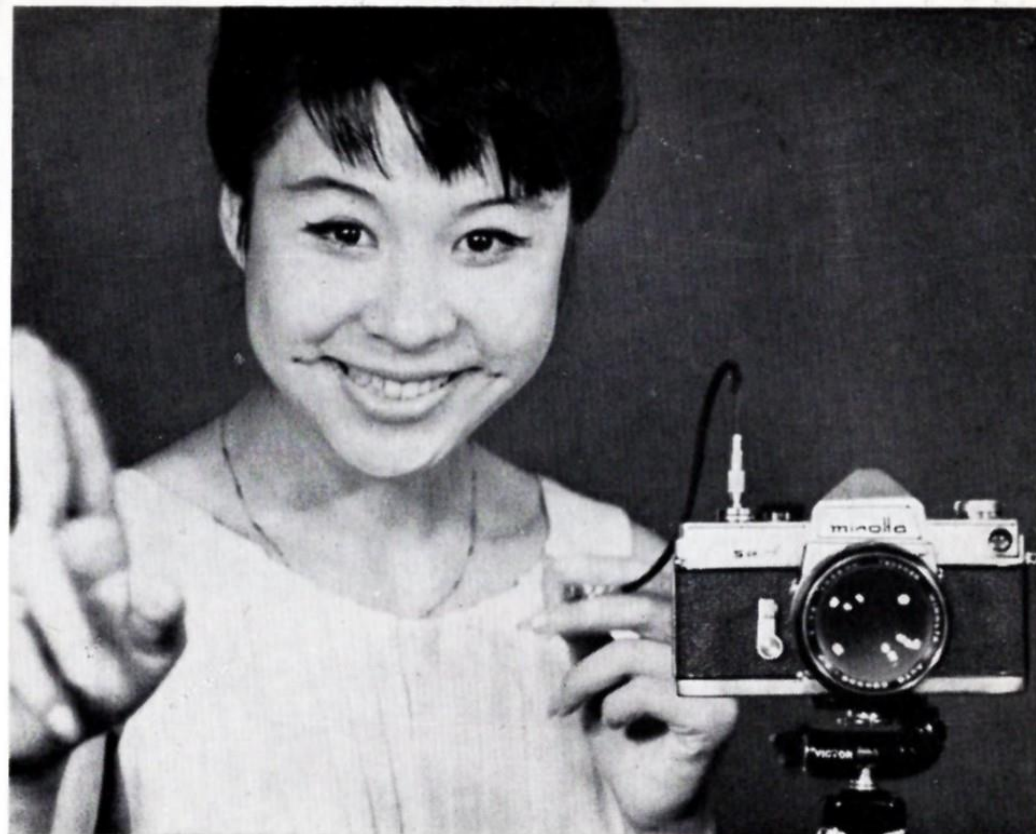

Unloading film

When you have finished the film roll, you will not be able to advance the lever any further. Do not force the advance lever or the film will tear out of the magazine and be impossible to rewind.

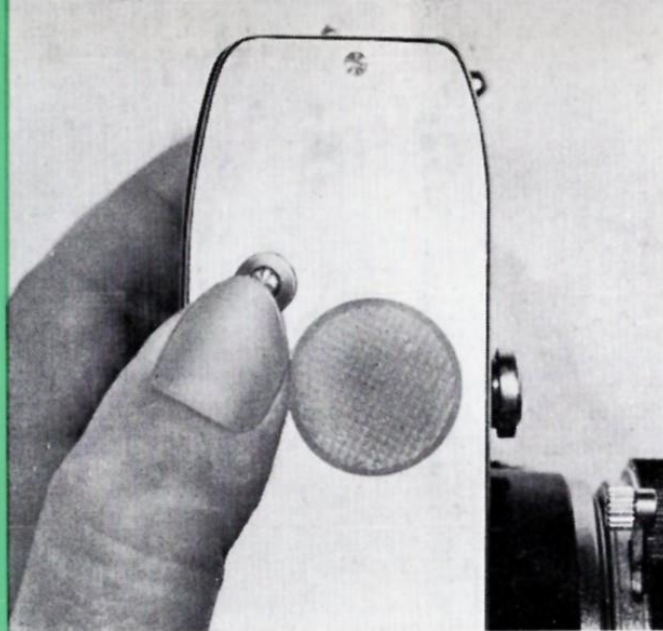

You must rewind the film back into the film magazine in order to unload the camera.

When you have finished taking pictures, push in the rewind release button and it will click into place. If the button should pop up, advance the lever slightly and push the button down again.

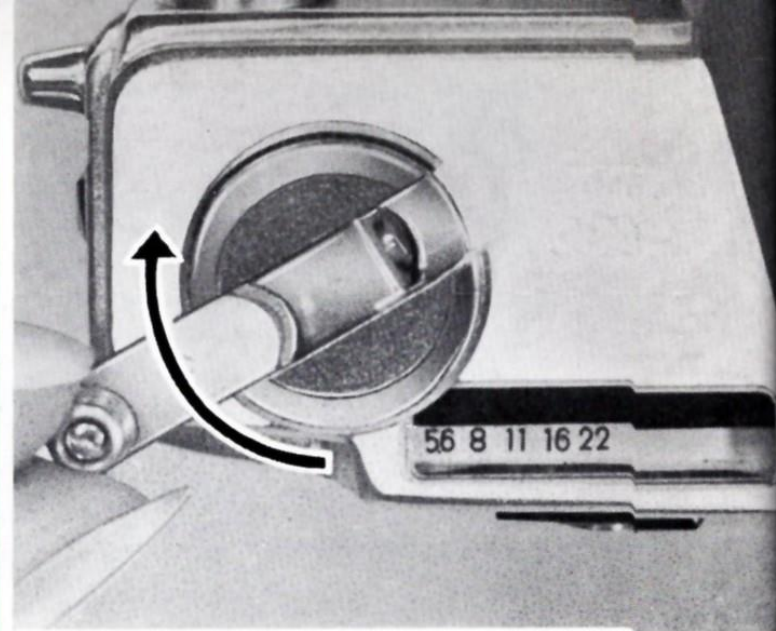

Raise up the crank and rewind in a clockwise direction as the arrow on the knob indicates until you feel the film slip out from the clip of the take-up spool and a sudden release of tension.

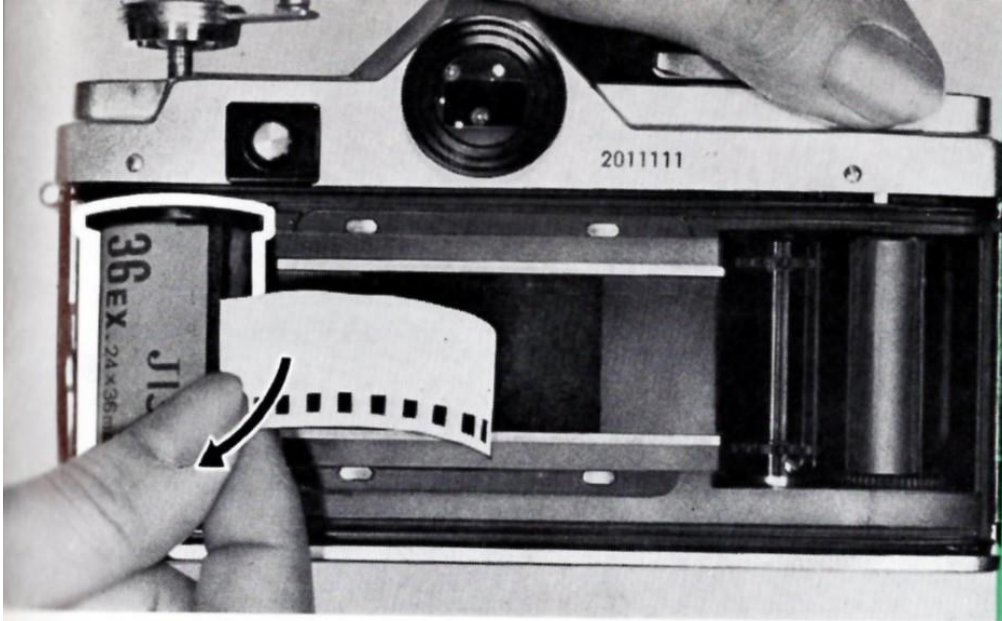

Open the camera back by pulling out the rewind knob as far as it goes. Remove the film magazine. Note: Loading or unloading film should be done in the shade.

Whenever rewinding film, please do not pull up the rewind knob. This action snaps open the camera back and your film would be exposed.

When opening the back cover, be sure not to touch the shutter curtain.



Setting the self-timer

The self-timer allows you to get yourself into the picture. (It can also be used to minimize blur at slow shutter speeds.) The self-timer has a built-in automatic bypass. If, after setting the timer, you don't want to use it, simply press the shutter release button and the timer will not operate.

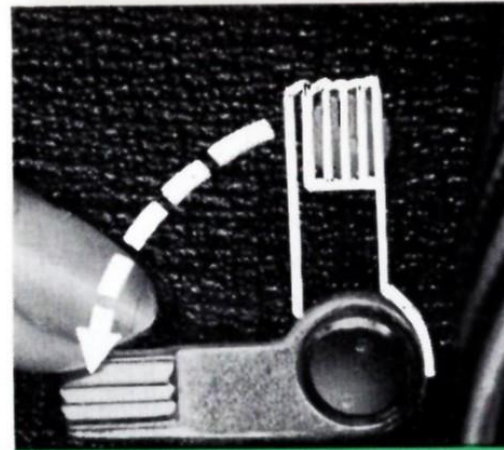

1, To set the timer, push down the lever. When it is all the way down as shown in the picture, you will get a time lapse of 10 seconds.

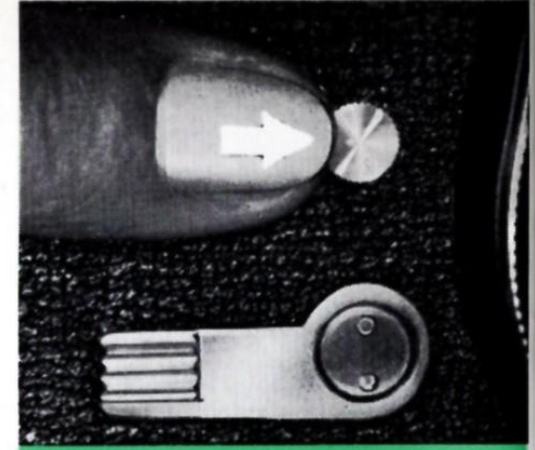

2. To start the timer, push the button towards the lens barrel. The shutter will release automatically in 10 seconds. If you set the shutter dial on "B" and use the self timer, you will get approximately a 2 second exposure automatically.

Flash photography

Flash is recommended for night shots, indoors or outdoors, and for filling in shaded areas. Your Minolta SR-7 is geared for both electronic flash and ordinary flash bulbs. Be sure to insert the flash cable into the correct terminal of the camera. The "X" terminal is for electronic flash; "FP" is for focal plane flash bulbs.



Flash bulbs

Use FP class bulbs (Focal Plane bulbs). The camera is synchronized at all shutter speeds from 1 second to 1/1000 second when using FP class bulbs.

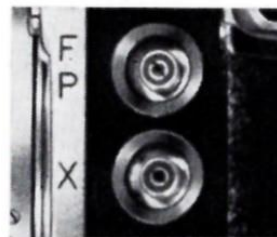

Electronic flash

Set the shutter speed dial to the red "X". Slower speeds may also be used. The camera is synchronized from 1 second to 1/50 of a second for electronic flash.





Attaching flash equipment

To attach flash equipment to your camera, an accessory shoe is provided (available at your local camera store) which fits over the penta prism viewfinder. Here is how it is installed.

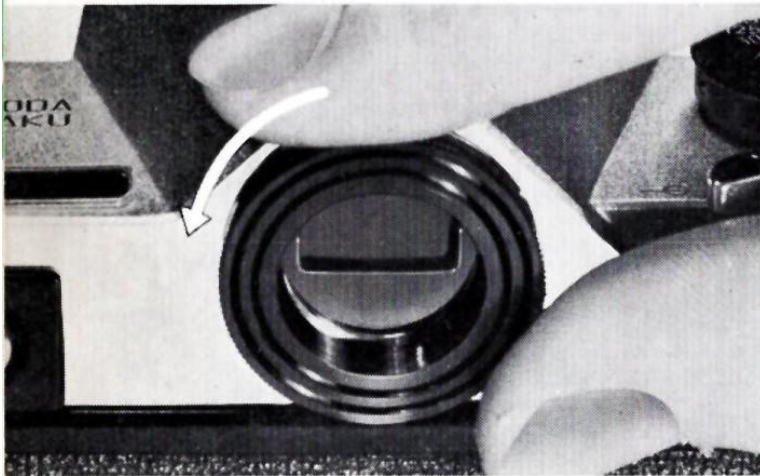

A) Turn the eyepiece on the viewfinder counterclockwise and remove it.

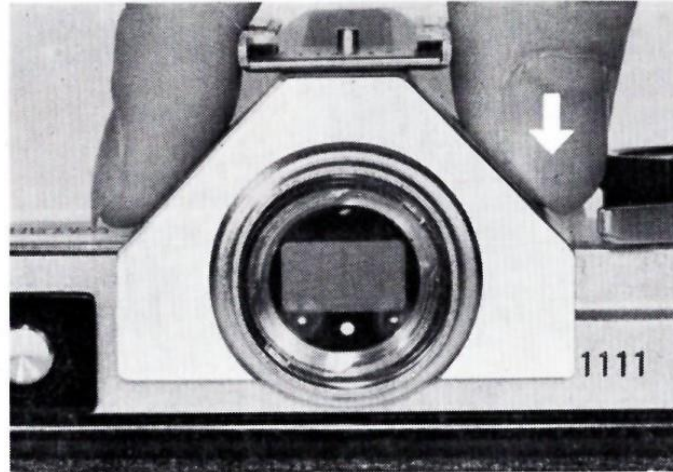

B) Insert the accessory shoe into the eyepiece.

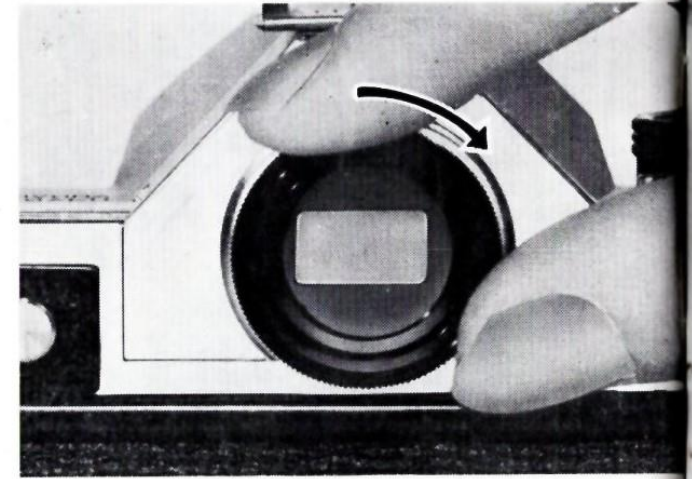

C) To lock the shoe on, replace the eyepiece to its original position.

D) Insert the flash gun into the accessory shoe from the rear. Then tighten the flash gun screw.

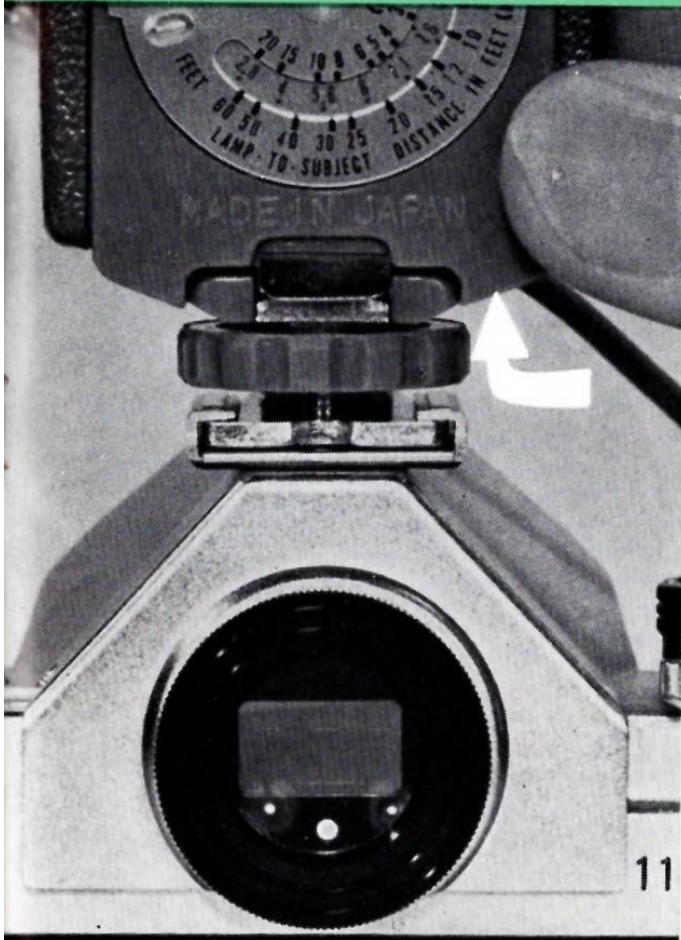

Shutter speeds for flash photography

(The speeds shown by oblique lines are the speeds you can use.)

Flash Bulbs		Shutter Speeds (sec.)											
		B	1sec.	1/2	1/4	1/8	1/15	1/30	X	1/60	1/125	1/250	1/500
F P Contact	F P class bulbs	/											
	E, class bulbs	/											
X Contact	M class bulbs	/											
	Speed light	/											

How to determine exposure

The important factor in flash photography is the aperture setting. This is determined by the brightness of the flash and the distance from the light to the subject. As these factors vary greatly, precise instructions are attached with flash bulbs and electronic flash.

Exposure guide numbers

The instructions accompanying flashbulbs or electronic flash will include guide numbers for the most popular films. Under the guide number system, you divide the guide number by the distance of the subject from the lamp in order to obtain the correct f/stop.

The guide number formula is:

$$f/\text{stop} = \frac{\text{Guide number}}{\text{distance}}$$

Using the mirror lock

The mirror lock button (located near the self-timer) is for use with the 21mm super wide angle accessory lens. With this lens, care must be taken so that the camera mirror does not touch the back of the lens. Hence, by turning the red dot on the mirror lock upwards, the mirror will lock in a permanently suspended position. Viewing is possible with the use of an accessory finder. The distance scale on the lens is used for focusing.

The mirror lock may also be used for continuous photography of a subject where viewing is not necessary. Turn the red dot downwards to return the mirror to its normal operating position.

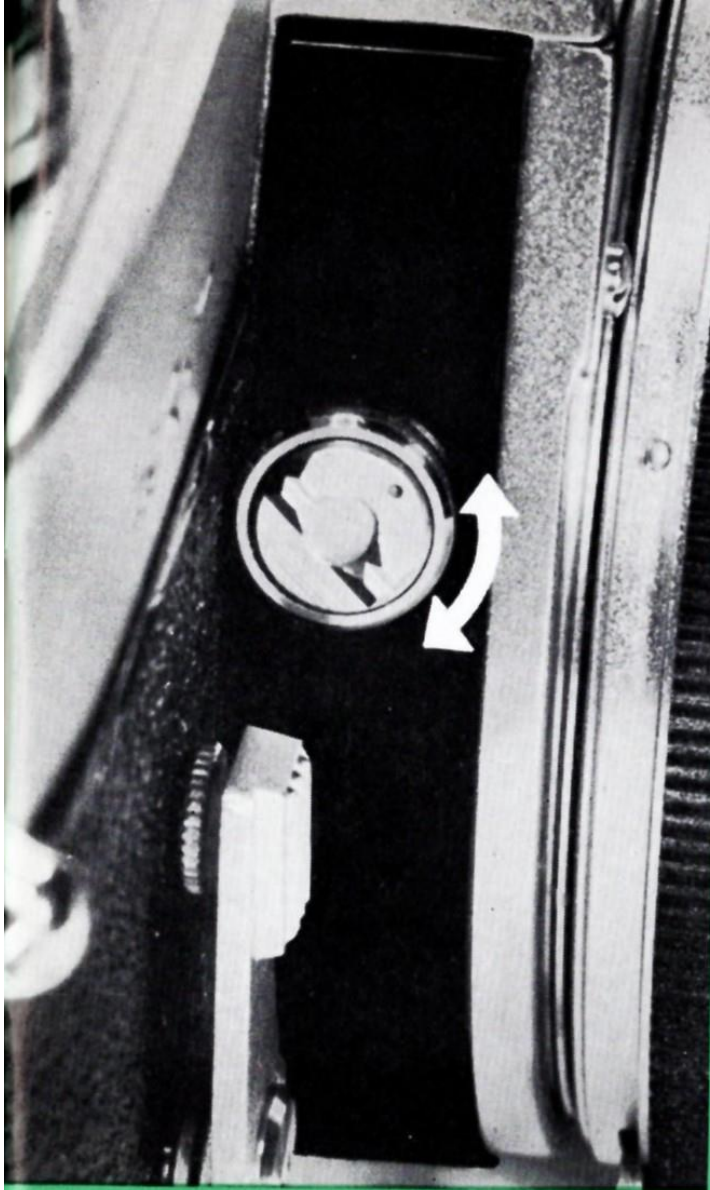

interchanging lenses



Minolta automatic pre-set lenses can be changed even after advancing the lever and still maintain the fullest aperture opening.



To remove the lens, push down the lens lock button and turn the lens barrel counterclockwise until it stops. Lift out carefully.



To attach the lens, insert it into the bayonet mount by lining up the red dot on the lens barrel with the red dot on the camera. Turn the lens clockwise until it stops.



CHOOSE THE WORLD FAMOUS ROKKOR LENSES FOR YOUR SR-7



Completely Automatic Rokkor lenses.
(Diaphragm opens and closes to pre-selected f stop automatically.)

- ② f2.8 35mm Wide angle lens
- ③ f2 55mm f1.8 55mm Standard lens
- ⑤ f3.5 100mm Telephoto lens
- ⑥ f2 100mm Telephoto lens
- ⑧ f2.8 135mm Telephoto lens
- ⑨ f3.5 200mm Telephoto lens

Manual Pre-set Rokkor lenses

- ① f4 35mm Wide angle lens
- ④ f4 100mm Telephoto lens
- ⑦ f4 135mm Telephoto lens
- ⑩ f4.5 300mm Telephoto lens
- ⑪ f5.6 600mm Telephoto lens



Relative fields of view with minolta interchangeable lenses

21 $\frac{m}{m}$

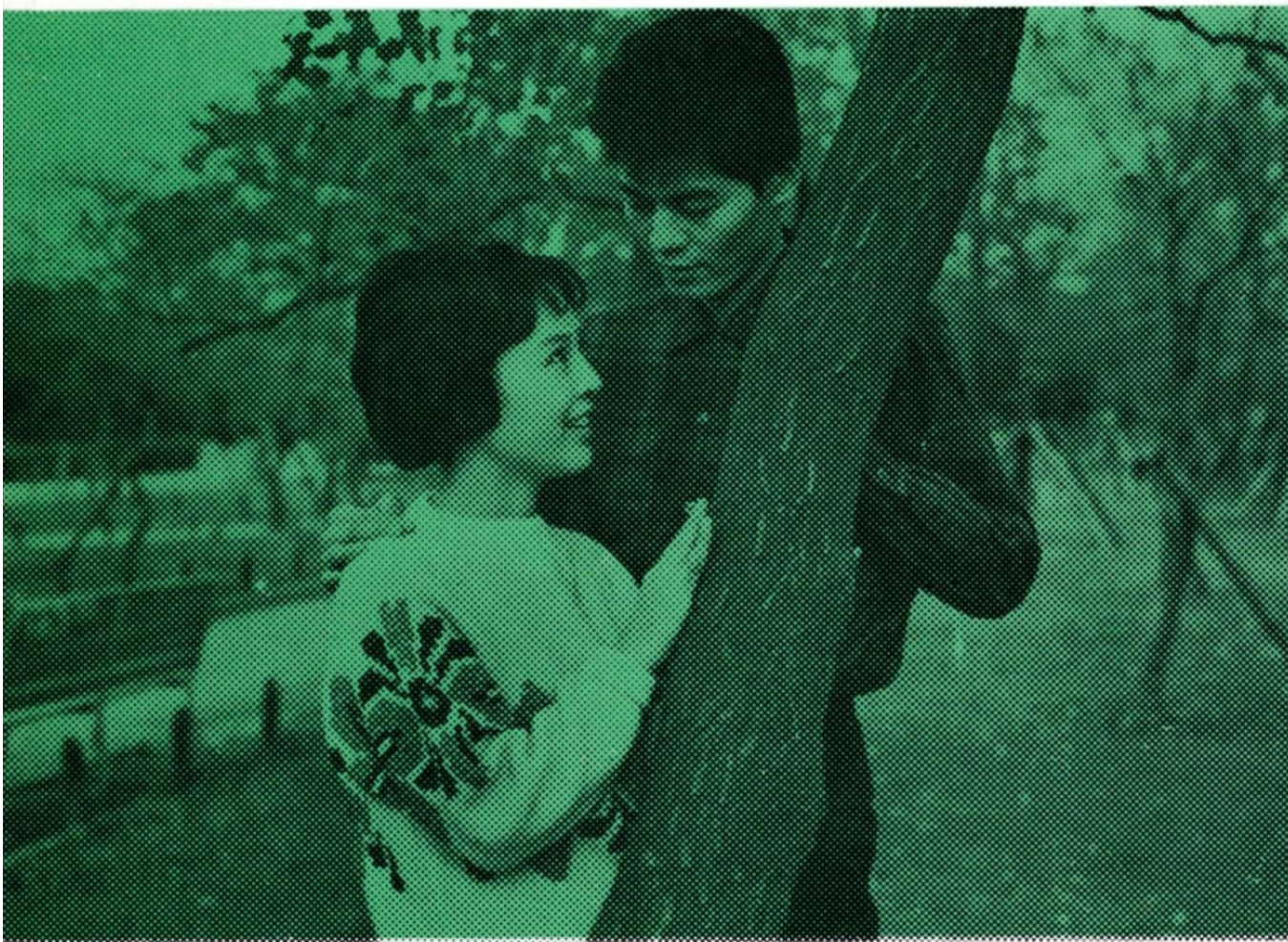

135 $\frac{m}{m}$

35 $\frac{m}{m}$



55 $\frac{m}{m}$



www.butkus.us

100 $\frac{m}{m}$



200 $\frac{m}{m}$



300 $\frac{m}{m}$



600 $\frac{m}{m}$

Interchangeable lenses for SR.

No.	Name	Focal Length (mm)	Maximum Aperture	Angle of View	Diameter of filter screw	Minimum Distance Focusing
①	W•ROKKOR QE	35	4.	64°	55 mm	40cm(1.25feet)
②	W•ROKKOR HG	35	2.8	64°	55 mm	25cm(0.85feet)
③	ROKKOR PF	55	1.8	43°	55 mm	50cm(1.75feet)
		58	1.4	41°	55 mm	60cm(2.0 feet)
④	ROKKOR TC	100	4.	24°	46 mm	120cm(4.0 feet)
⑤	TELE ROKKOR QE	100	3.5	24°	55 mm	120cm(4.0 feet)
⑥	TELE ROKKOR	100	2	24°	62 mm	120cm(4.0 feet)
⑦	ROKKOR TC	135	4.	18°	46 mm	150cm(5.0 feet)
⑧	TELE ROKKOR PG	135	2.8	18°	55 mm	150cm(5.0 feet)
⑨	TELE ROKKOR QF	200	3.5	12°	67 mm	250cm(8.0 feet)
⑩	TELE ROKKOR TD	300	4.5	8°	77 mm	405cm(15.0feet)
⑪	TELE ROKKOR TD	600	5.6	4°	126 mm	1000cm(33.0feet)

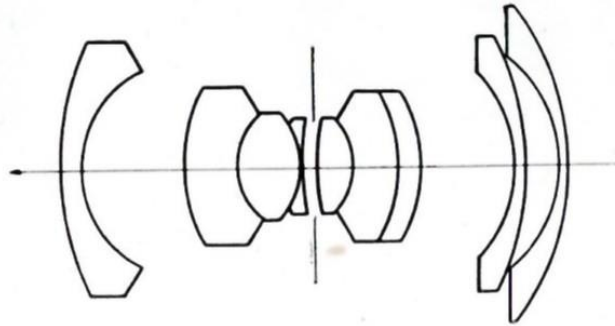

Super wide angle lens

This Minolta 21mm super wide angle lens has an extremely wide 92° picture angle, almost twice that of the standard lens. The lens permits shooting wide panoramic views, snap-shots in restricted spaces or photography with an exaggerated perspective.

Specifications:

Super wide angle-Rokkor 21mm, f4.5 to f16

Picture angle - 92°

Distance Scale - Less than 36 inches

Filter - From 55

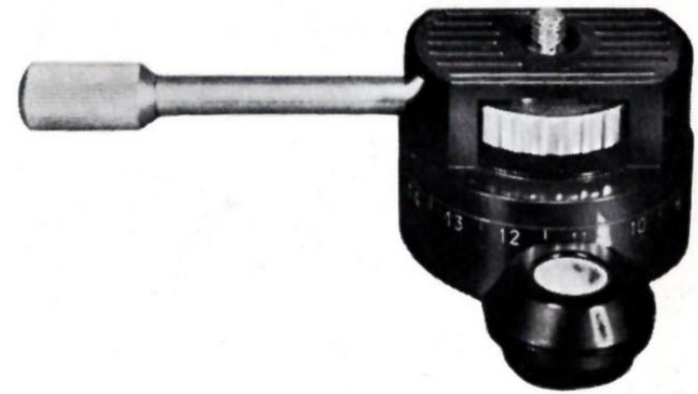

Panorama head

With the Minolta panorama head, an extensive range can be photographed in segments and printed as a single picture. The panorama head permits shifting the camera angle after each picture, shooting as much as 360° if you wish. Each film can be subsequently joined into one dramatic panoramic view. Especially effective for perspective photography with the extended horizon distinctly shown.



New type interchangeable lenses



Macro Rokkor QF,
 F3.5, 50mm,
 45° Angle
 Filter Screw Mount 55mm



Rokkor TC, F4, 135mm

A versatile lens for nature photography, animals and plants. With the Minolta Extension Bellows II, Rokkor TC can be used from infinity to close up—1:1.1 ratio. The lens is also valuable in portraiture, copying and commercial photography.

Not only for general photography, but also especially good for copying and macrophotography. Macro Rokkor QF consists of reverse ring, intermediate ring and Leica mount adapter ring. The lens is designed for use from infinity to 9 inches without adapter ring; from infinity to 8 inches when reversing ring is used. The enlarged size will be 1:1.



Rokkor Zoom Lens

F3.5, 80-160 mm

15 Element.

Angle 16°-32°

Filter Screw Mount-77mm

Minimum distance-250cm (8ft.)

With attachment-140cm (4¾ft)

Fully Automatic Diaphragm

This is the new Minolta Rokkor Zoom lens that functions as several lenses. It zooms from 80 to 160mm with no shift in focus while zooming. Also, you get a clear, distinctive picture all the time with no change of brightness even at maximum telephoto setting. It's ideal as an all-purpose telephoto lens. Weight : 1350gr



Extension tubeset

Five varieties of extension tubes can be used singly or in combination to get the lens closer to the object than 9 inches.

Extension bellows

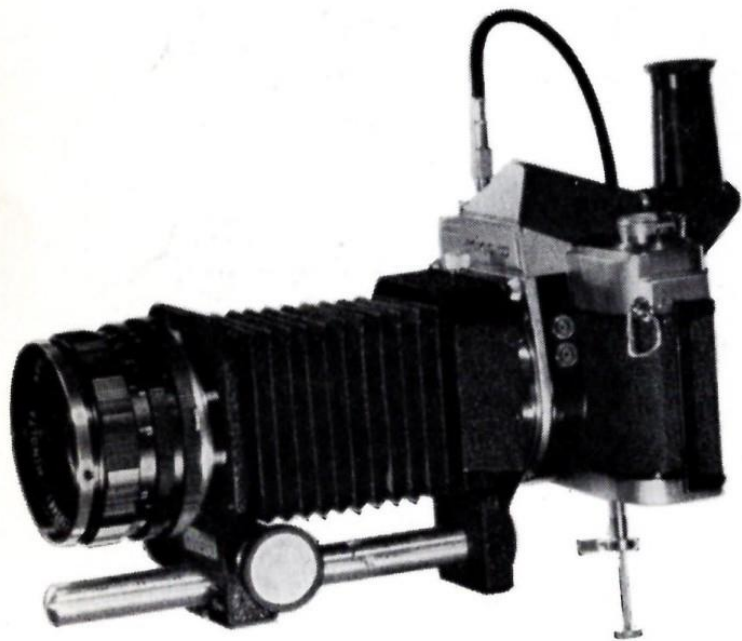

A versatile device for extreme close-ups as in the photography of animals and plants, for example. There are two types of Minolta Bellows, type I and type II (deluxe). Type I is a folding compact type. Type II has the slide copying attachment.

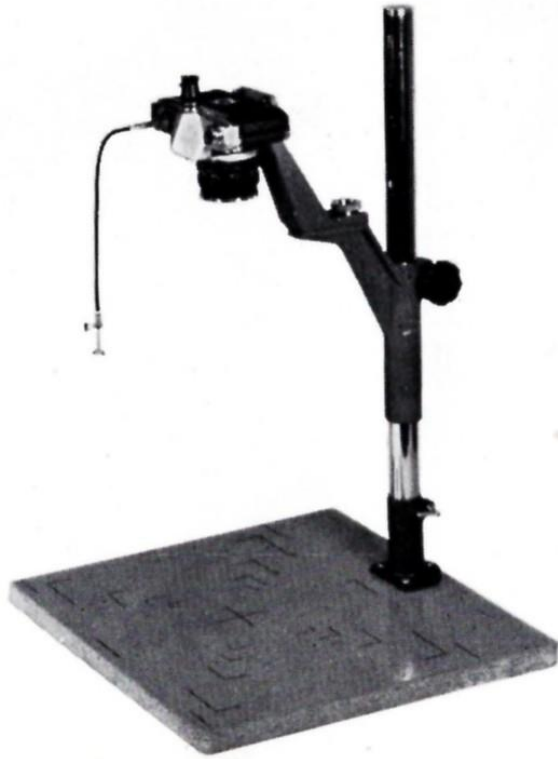

Copying stand

With the camera held rigidly on a suitable support, most close-up work, copying of printing matter, etc., are easily accomplished. Combined with extension devices, the copy stand will expand the versatility of your SR.



Microscope adapter

This adapter is used between the microscope and the camera body when taking microphotos. You can easily take micropictures of moving objects while watching them through the lens.

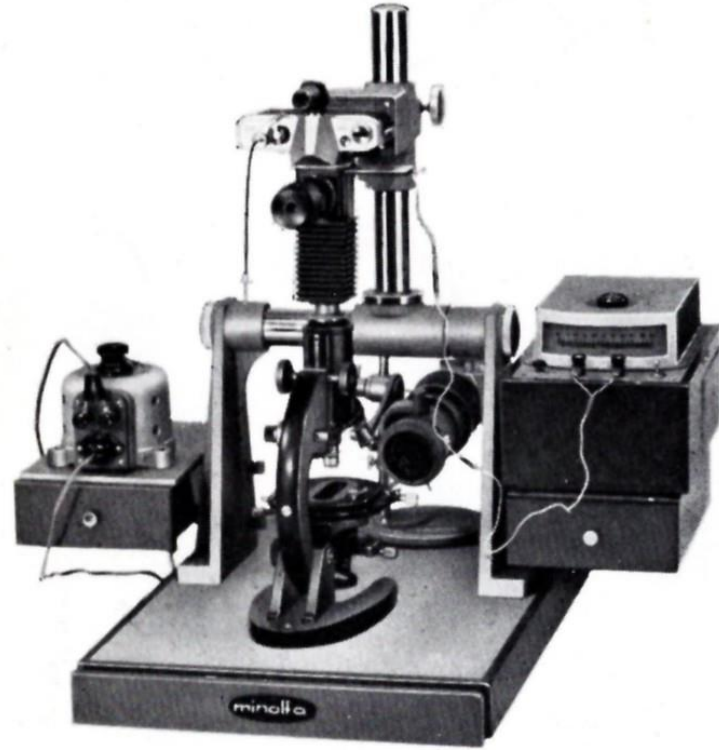

Universal microscope photo system

This equipment is designed to record faithfully and accurately results of microscopic research. It has two finders and a highly efficient exposure meter. The equipment can also be used for reproduction of literature and film title.



Angle finder

The angle finder attaches to the eyepiece mount and permits you to view the subject at right angles.

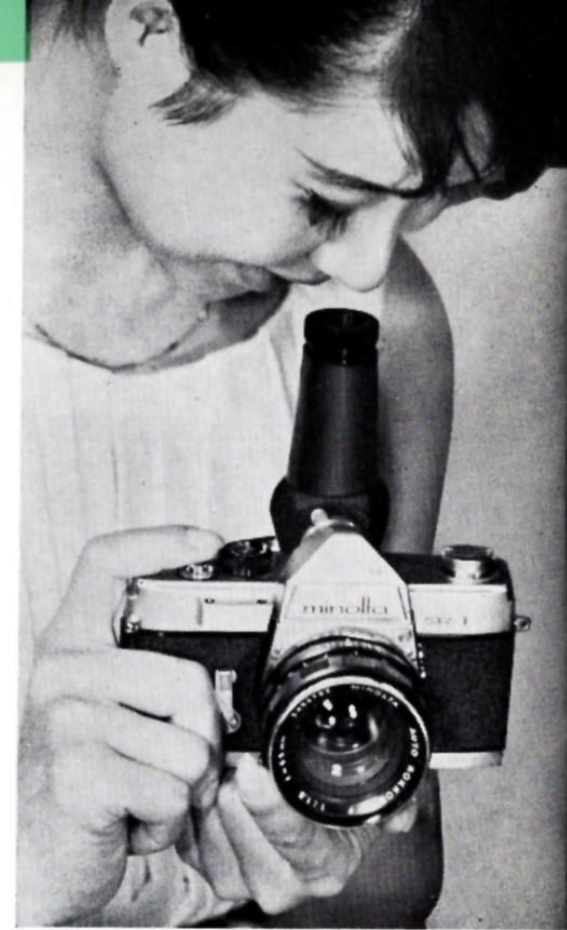



Magnifier

The magnifier is used for precise focusing in telephotography, copying, ultra close-ups and microphotography.



Eyepiece correction lenses

Five different lenses designed for individual diopter of far-sighted eyes are useful for easier focusing.



Accessory clip

With the SR accessory clip you can attach a flash gun to your camera.



Lens Shade

A lens shade is recommended to prevent any stray light from entering the lens which will cause glare on the picture. Especially essential in synchroflash work.

35mm f 2.8	Screw mount	} 55mm
" f 4		
55mm f 2	Screw mount	
" f 1.8		

Telephoto lenses include a lens shade.



Filters

Filters are used to obtain truer or more dramatic results or to secure other special effects.

35 mm f 2.8, f 4	} Filter screw mount 55mm
55 mm f 1.8, f 2	
100 mm f 3.5	
135 mm f 2.8	
100 mm f 4	Filter screw mount 43mm
100 mm f 2	Filter screw mount 62mm
135 mm f 4	" 46mm
200 mm f 3.5	" 67mm
300 mm f 4.5	" 77mm
600 mm f 5.6	" 126mm

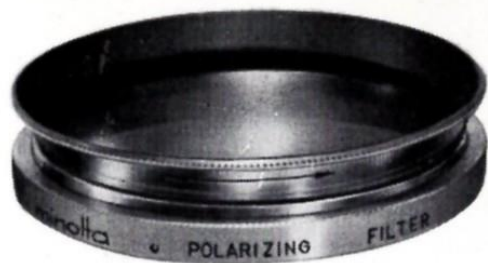

Polarizing Filter

A polarizing filter controls or eliminates reflections on non-metallic surfaces i.e. glass or highly finished wood or plastic. It can also be used to darken the sky very dramatically.

Minolta polarizing filters are:

- | | |
|--------------------------------------|-----------------|
| for 55 mm f 1.8 or f 2 standard lens | |
| 100 mm f 3.5 | telephoto lens |
| 135 mm f 2.8 | " " |
| 35 mm f 2.8 | wide angle lens |
| 35 mm f 4 | " " |



Minolta Universal Flash Gun

Excellent pictures can be taken even in dark places, indoors or at night by using flash with the SR camera. Accessory clip is easily used to fix the flash gun to the SR.



Leica mount type adapter

With the Leica mount type adapter, Leica mount type lenses are fitted to the SR.

These lenses, however, can be used only for close-ups and copying, since they are designed for a different back-focus.



Exakta mount type adapter

With this adapter, any lens fitted with Exakta bayonet mount can be used with the SR from the nearest distance to infinity.



Photo Oscilloscope Unit

As a result of the remarkable developments in the electronics industry and research work, the use of cathode ray tube oscilloscopes has increased at a rapid pace.

This unit can be used for accurate photography of images in electronics testing and research.

Guarantee certificate

Your Minolta SR-7 is guaranteed for a period of one year from the date of purchase against defects of any kind due to workmanship or quality of materials used in its manufacture.

Service

Any bona-fide Minolta camera dealer is fully qualified and experienced to service your Minolta camera .You'll find Minolta dealers throughout the world.

Minolta Camera Hamburg,

c/o F. Kanematsu & Co., GmbH.,
Kajen 10,
Hamburg 11,
West Germany.

Minolta Corporation,

200 Park Avenue South,
New York 3, N. Y.,
U. S. A.



Minolta masters photography

Minolta
MINOLTA CAMERA CO., LTD.