



This manual is for reference and historical purposes, all rights reserved.

This page is copyright© by M. Butkus, NJ.

This page may not be sold or distributed without the expressed permission of the producer

I have no connection with any camera company

On-line camera manual library

This is the full text and images from the manual. This may take 3 full minutes for the PDF file to download.

If you find this manual useful, how about a donation of \$3 to: M. Butkus, 29 Lake Ave., High Bridge, NJ 08829-1701 and send your e-mail address so I can thank you. Most other places would charge you \$7.50 for a electronic copy or \$18.00 for a hard to read Xerox copy.

This will allow me to continue to buy new manuals and pay their shipping costs.

It'll make you feel better, won't it?

**If you use Pay Pal or wish to use your credit card,
click on the secure site on my main page.**

PayPal Name Lynn@butkus.org

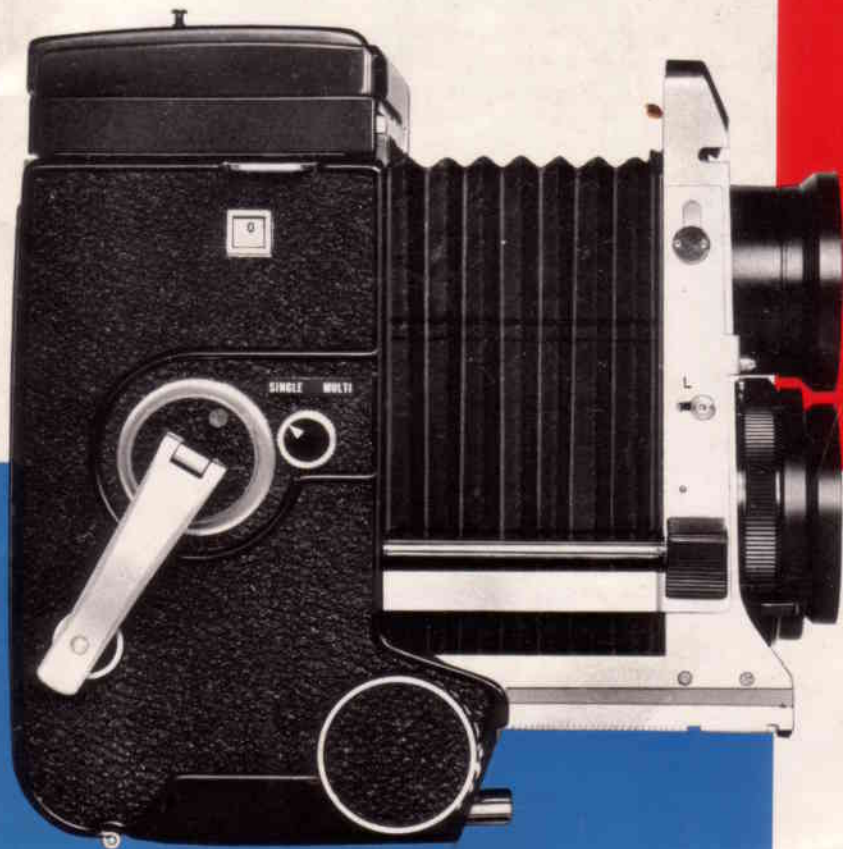

Mamiya C330

D 136673

INSTRUCTIONS

CONTENTS

We are highly gratified that you have selected the MAMIYA C330 from among so many makes of cameras on the market. Before using the camera, please read these instructions very carefully, and learn the correct method of handling it. By becoming completely familiarized with the MAMIYA C330, you can make the most of the splendid opportunities this fine camera offers for many years to come.

This MAMIYA C330, an exceptionally high-grade camera, was designed by emphasizing further improvements on the popular MAMIYA C series. Retaining the many features of the MAMIYA C series cameras which have won highest praise from professional photographers the world over as unique twin-lens reflex cameras (2 1/4 in. square format) with interchangeable lenses, especially stressed was minimizing size and weight plus handling ease.

Final results reveal that this MAMIYA C330, an ideal camera for professional photographers, is also a wise choice for the many advanced amateurs who wish to take advantage of fine details in enlargements which only a large-format camera truly makes possible.

The MAMIYA C330 accepts all interchangeable lenses of the current Mamiya C series as well as all of the accessories except the single-exposure attachment.

In addition, various new accessories have been designed for this model. With the wide selection of all these interchangeable lenses and accessories, you can further widen your scope of photography by making the most of the unlimited versatility the MAMIYA C330 offers.

	page
Read These Instructions Before Using Your MAMIYA C330	2
Nomenclature of Operating Parts	5
Opening and Closing the Back Cover	7
Before Loading Film	8
Loading Film.....	9
Handling the Focusing Hood	11
Changing the focusing hood	13
Changing the focusing screen	13
Before Taking Pictures	14
Setting the parallax correcting dial	14
Correcting parallax	14
Compensating exposure	14
Indicating film speed and type on respective windows	15
Distance Scale	16
Taking Pictures	17
Shutter Operations	18
Using the multiple exposure selector	18
Locking the shutter button	18
When no film is loaded in the camera	19
Photographing by Flash Unit	20
Changing Lenses	21
Changing the Back Cover.....	23
Tripod Socket	23
Accessories	24
Lens Specifications Table.....	32
Depth of Field Table	34
System chart for MAMIYA C330	41

CONTENTS

page

We are highly gratified that you have selected the MAMIYA C330 from among so many makes of cameras on the market. Before using the camera, please read these instructions very carefully, and learn the correct method of handling it. By becoming completely familiarized with the MAMIYA C330, you can make the most of the splendid opportunities this fine camera offers for many years to come.

This MAMIYA C330, an exceptionally high-grade camera, was designed by emphasizing further improvements on the popular MAMIYA C series. Retaining the many features of the MAMIYA C series cameras which have won highest praise from professional photographers the world over as unique twin-lens reflex cameras (2 1/4 in. square format) with interchangeable lenses, especially stressed was minimizing size and weight plus handling ease.

Final results reveal that this MAMIYA C330, an ideal camera for professional photographers, is also a wise choice for the many advanced amateurs who wish to take advantage of fine details in enlargements which only a large-format camera truly makes possible.

The MAMIYA C330 accepts all interchangeable lenses of the current Mamiya C series as well as all of the accessories except the single-exposure attachment.

In addition, various new accessories have been designed for this model. With the wide selection of all these interchangeable lenses and accessories, you can further widen your scope of photography by making the most of the unlimited versatility the MAMIYA C330 offers.

Read These Instructions Before Using Your MAMIYA C330	2
Nomenclature of Operating Parts	5
Opening and Closing the Back Cover	7
Before Loading Film	8
Loading Film.....	9
Handling the Focusing Hood	11
Changing the focusing hood	13
Changing the focusing screen	13
Before Taking Pictures	14
Setting the parallax correcting dial	14
Correcting parallax	14
Compensating exposure	14
Indicating film speed and type on respective windows	15
Distance Scale	16
Taking Pictures	17
Shutter Operations	18
Using the multiple exposure selector	18
Locking the shutter button	18
When no film is loaded in the camera	19
Photographing by Flash Unit	20
Changing Lenses	21
Changing the Back Cover.....	23
Tripod Socket	23
Accessories	24
Lens Specifications Table.....	32
Depth of Field Table	34
System chart for MAMIYA C330	41

Read These Instructions Before Using Your MAMIYA C330



Adjust the direction of the pressure plate according to the film used (120 roll film or 220 roll film).

See page 8
for details.

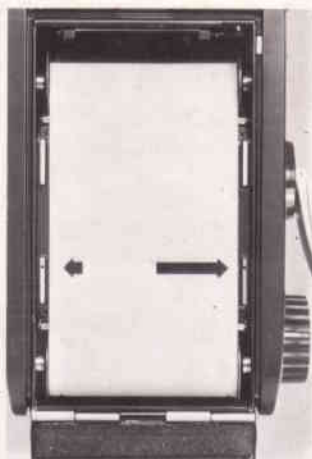

When loading film, insert both film spools correctly.

See page 9
for details.



When closing the back cover, firmly press both sides of the back cover catch button.

See page 7
for details.



In coinciding the focal length of the lens to be used, set the parallax correcting dial. The amount of parallax correction and the exposure factor are readable on the focusing screen in the finder.

See page 14
for details.

■ Read These Instructions Before Using Your MAMIYA C330 (cont.)

When this camera is under any of the conditions described as follows, the shutter release button cannot be depressed. In this case, absolutely do not use force.

1. When lens change knob is set on "UN-LOCK".

2. When shutter release lock button is set on the letter "L".

3. When multiple exposure button is set on "SINGLE," and ...



A red warning signal is visible on the focusing screen.

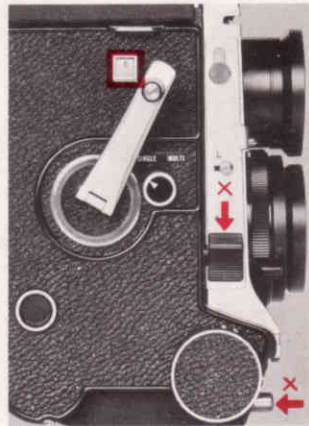
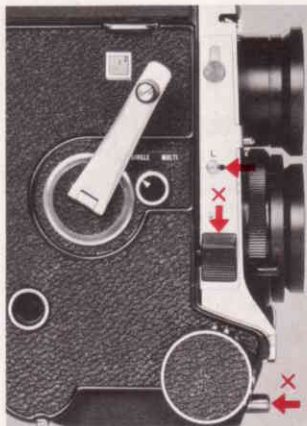

(1) When film is not loaded (exposure counter indicates "0").



(2) When the film has not been wound.

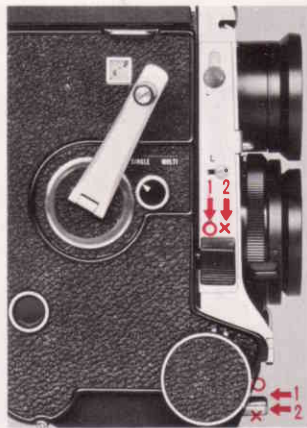

(3) When the shutter release button has already been pressed.



(4) When the last film in roll is exposed (after 12 or 24 exposures).

When taking ordinary pictures with roll film, set the multiple exposure selector triangular mark toward the word "SINGLE."



For multiple exposures, when the shutter is freely released without loading film, or when the single exposure attachment is used, set the triangular mark toward the word "MULTI."

Nomenclature of Operating Parts

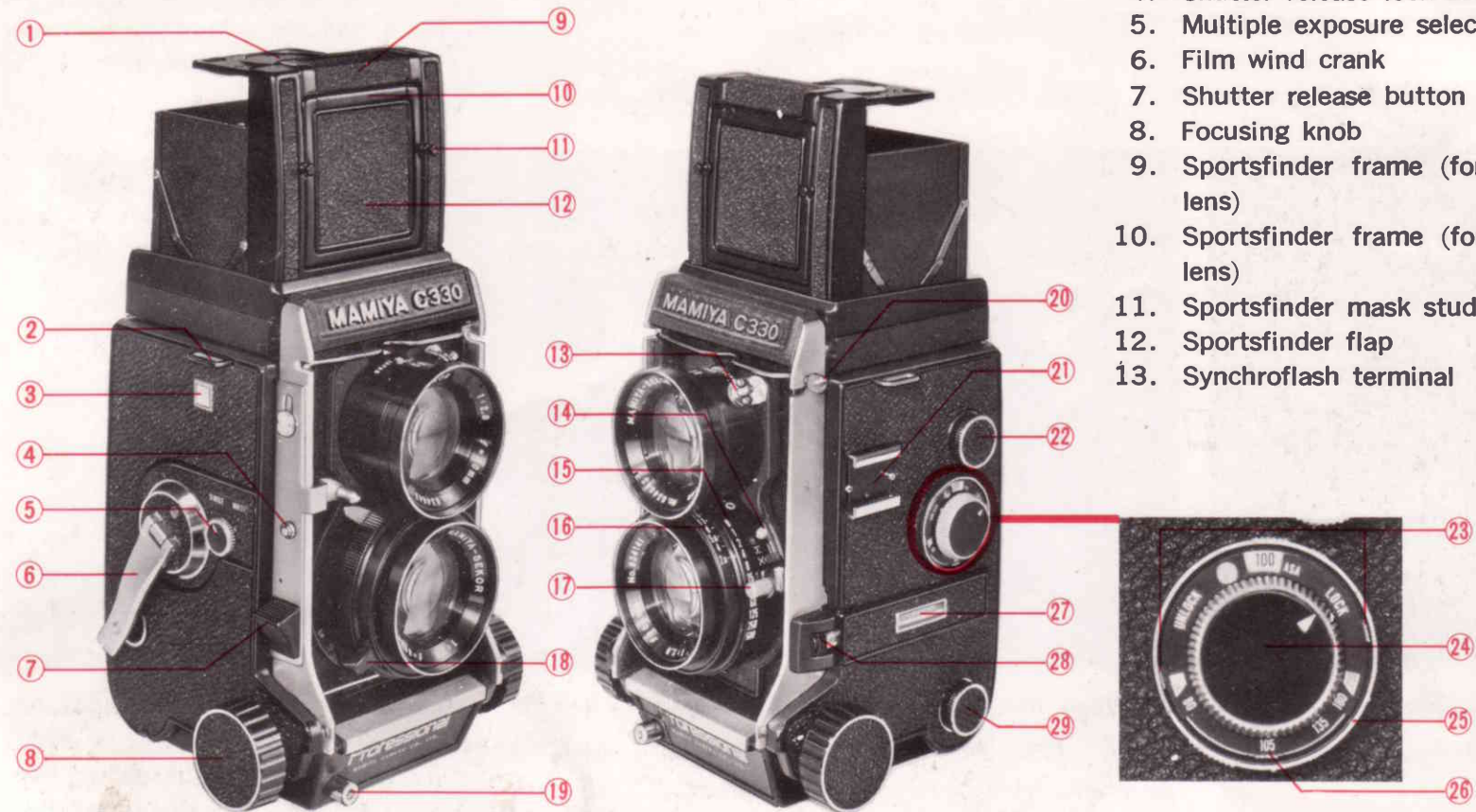

1. Magnifying glass
2. Strap eyelet
3. Exposure counter
4. Shutter release lock button
5. Multiple exposure selector
6. Film wind crank
7. Shutter release button (upper)
8. Focusing knob
9. Sportsfinder frame (for 65mm lens)
10. Sportsfinder frame (for 80mm lens)
11. Sportsfinder mask stud
12. Sportsfinder flap
13. Synchroflash terminal

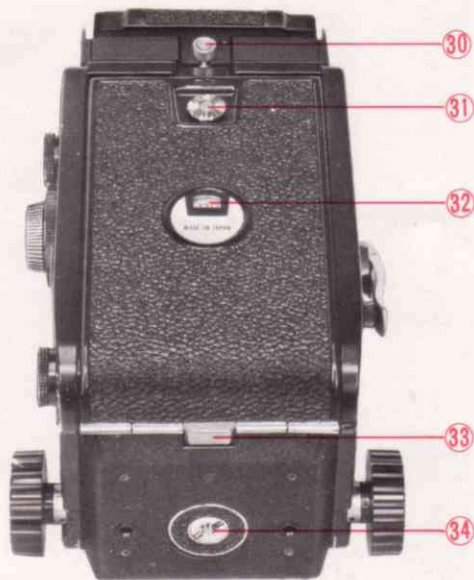

- | | |
|---|--|
| 14. Synchroflash M-X selector | 28. Distance scale revolving knob |
| 15. Shutter speed ring | 29. Spool change knob (lower) |
| 16. Aperture ring | 30. Focusing hood lock screw |
| 17. Shutter cocking lever | 31. Back cover catch button |
| 18. Aperture control knob | 32. Film indicating window (120/
220) |
| 19. Shutter release button (lower)
with cable release socket | 33. Back cover hinge release |
| 20. Lens catch bracket | 34. Tripod socket |
| 21. Accessory shoe | 35. Eye opening for sportsfinder |
| 22. Spool change knob (upper) | 36. Focusing screen frame catch |
| 23. ASA indication shifting lever | 37. Focusing screen frame guide pin |
| 24. Lens change knob | 38. Take-up spool chamber |
| 25. Parallax correcting dial | 39. Start mark |
| 26. Film type indication select lever | 40. Film chamber |
| 27. Distance scale window | 41. Film pressure plate |

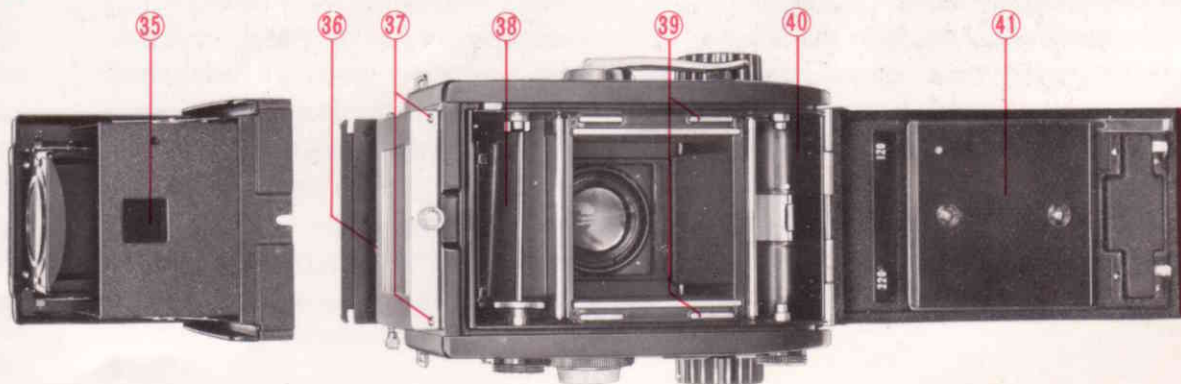

■ Opening and Closing the Back Cover

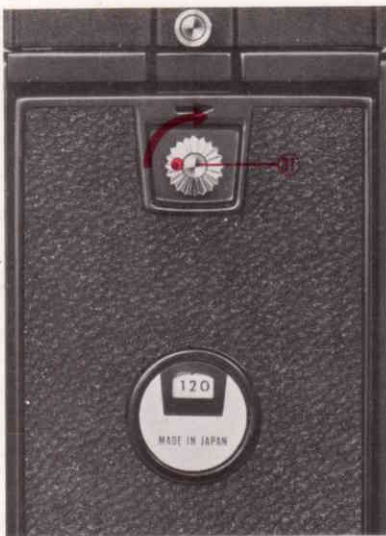

Twist the back cover catch button (31) until the red mark on the button faces upward. Then, by pressing the button in the direction indicated on the back cover, the back cover will open. The figure in the exposure counter automatically returns to "0" when the back cover opens.

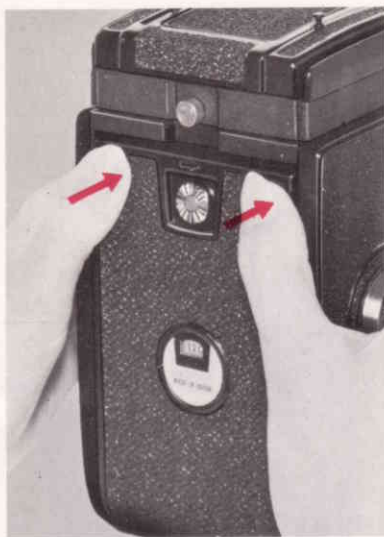

When closing the back cover, firmly press both sides of the back cover catch button, making sure that neither side of the back cover is open or loose. Unless the back cover is closed tightly, the automatic film stopper will not work. Also, if only one side of the back cover is pressed when closing, the automatic film stopper may not function.

When the back cover is closed, by twisting the back cover catch button counterclockwise until the red mark of the button is on the left side, the back cover can be locked. If the button is twisted and the red mark moved to the left side before closing, the back cover will automatically lock when closed.

■ Before Loading Film



This camera accepts either 120 or 220 roll film. It has an automatic film stopper and a double exposure prevention device. Take the following steps before loading a film:

1. By turning the multiple exposure selector (5), set the triangular mark toward the word "SINGLE."

This action locks the shutter release button until the film is wound, preventing accidental double exposures.

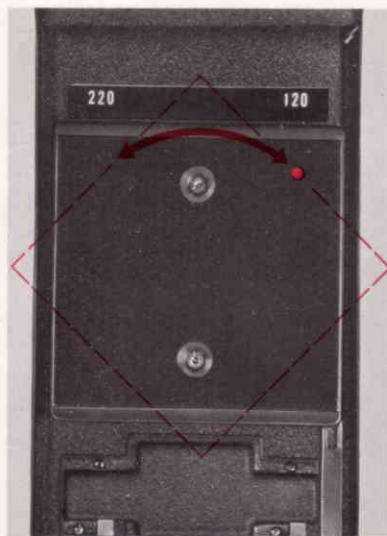

2. Adjust direction of the pressure plate according to the film used.

Open the back cover, twist the pressure plate (41) either to the right or left 90 degrees until the red mark on the pressure plate matches either 120 or 220.



Subsequently, when closing the back cover, the film stopper mechanism is automatically set to coincide with the film frame number.

The figure 120 or 220 will appear in the film indicating window (32), informing the user of the loaded film size when the back cover is closed.

■ Loading Film



1. Open the back cover and pull out the spool change knob (22), then insert an empty spool into the take-up spool chamber (38) so that it engages the winding axis. Release the spool change knob.

Pull out the spool change knob (29), and insert a roll of film in the film chamber (40).



PRECAUTIONS

By turning the spool change knobs (22) and (29) either to the right or left after pulling them outward, the knobs stay at their protruded positions. Turn the knobs backward to reinsert them.

If both spool change knobs are not returned to their original positions after loading a film, unbalanced film winding will result.

Should the spool change knob not return to its original position, move the spool slightly to the front and rear or up and down.

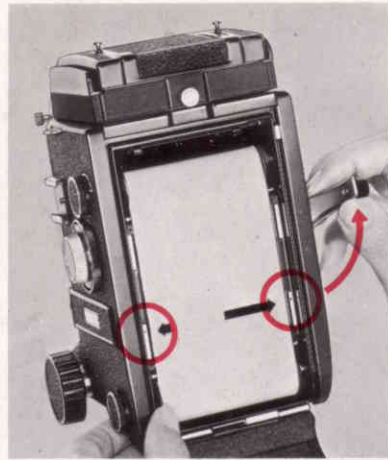

2. Pull out the leader paper of the film and guide it into the slit of the take-up spool, turn the film wind crank (6) clockwise until the start mark on the leader paper matches the start marks (39) on the camera.

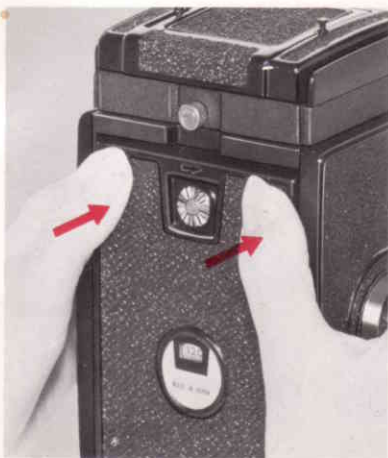

3. Close the back cover. When closing the back cover, firmly press both sides of the back cover catch button. Twist the button counter-clockwise, so that the back cover does not open unexpectedly.

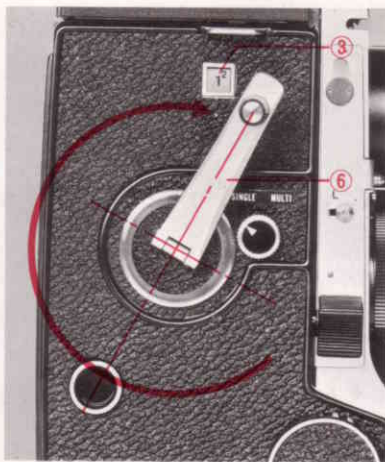

4. Turn the film wind crank (6) clockwise until it stops. Figure 1 appears on the exposure counter (3) at the position where the crank stops diagonally upward, and the shutter is automatically set. Now the camera is prepared for the first exposure.

The crank cannot be turned in reverse.

Turn the crank each time one picture is exposed. Regardless of the number of pictures taken, the crank always stops at a diagonally upward position. In this position, when folding the crank in the opposite direction, the crank can be recessed in the body.

■ Handling the Focusing Hood



Raising the Focusing Hood

By pulling up the rear of the finder frame (9), the focusing hood automatically springs up into position.

By pushing in the top of the sportsfinder flap (12) at the center of the finder frame, the magnifying glass swings up into position. While looking into the ground glass focusing screen in this position, turn the focusing knob (8) to focus. After focusing, push down the magnifying glass, and decide the photo composition by using the entire view on the focusing screen as a guide.



Using the Focusing Hood as a Sportsfinder

1. By pulling up the magnifying glass and pushing down the sportsfinder flap, and by attaching the latter to the catch at the bottom of the focusing hood, the hood can be used as a sportsfinder for the 80mm standard lens.

2. After pushing down the flap (12), also fold down the finder frame (10) to obtain the field of view for the 65 mm lens.



3. When using the 105 mm, 135mm, 180mm, or 250mm lens, attach the respective sportsfinder mask for the lens used on the finder mask stud (11), adjusting for the change in field of view.



4. To return the finder frame (10) to its original position, by pushing and releasing the left side plate of the hood with a finger tip (left side when the camera is held for photographing), the finder frame will automatically return to its position.



5. To return the sportsfinder flap, push the right side plate.

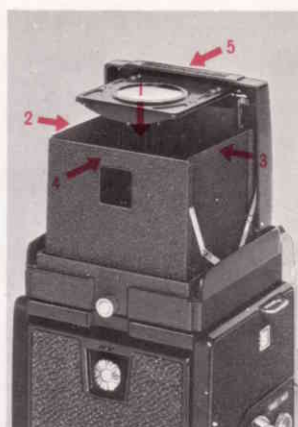

Folding the Focusing Hood

Return the sportsfinder flap, push down the magnifying glass, fold the side plates inward and the back plate downward, finally folding the finder frame (9).

■ Handling the Focusing Hood (cont.)

Changing the Focusing Hood



The focusing hood can be replaced with various finders available for this camera as accessories.

How to Remove the Focusing Hood

By turning the focusing hood lock screw (30) counterclockwise to loosen it, pull back the hood and move it upward; then the hood can be taken off.

How to Attach a Focusing Hood

Match the grooves on the hood's front both sides to the pins of the camera body, fit the groove on the hood's rear to the focusing hood lock screw, then fasten it.

Changing the Focusing Screen

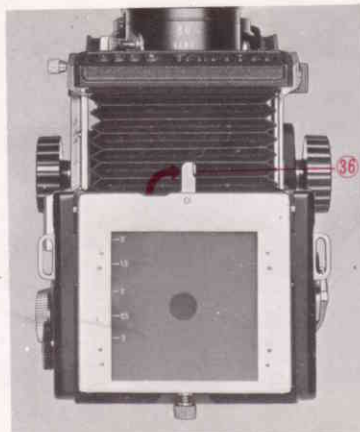

Various focusing screens inserted in convenient individual frames are interchangeable for this camera as accessories. They can be freely exchanged when desired.

Removing the focusing screen

Initially remove the focusing hood, then extend the bellows by turning the focusing knob. Release the frame catch (36) by turning it in the direction of the arrow, as shown in the photo. Next, by pulling back the focusing screen frame after raising its front portion upward, the focusing screen frame can be removed.

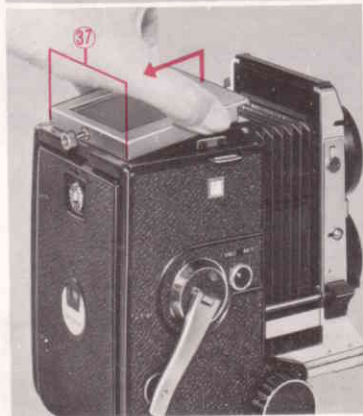

Installing the focusing screen

After positioning the two holes on the rear side of the focusing screen over the two guide pins (37) on the body, depress the front portion. Return the frame catch to its original position while depressing the front portion of the focusing screen frame.

■ Before Taking Pictures

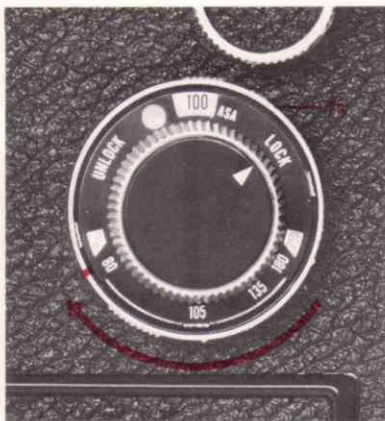

Setting the Parallax Correcting Dial

By turning the parallax correcting dial (25), set the dial index to the focal length of the lens used. Subsequently, while the lens is being extended, the pointer will appear on the upper, left portion of the focusing screen. The position of this pointer indicates parallax and the exposure factor.

Correcting parallax:

When the pointer appears on the focusing screen, the upper portion visible above the pointer will be cut off on the film. Be sure that the subject is satisfactorily appears under the lower portion of this pointer. When using the camera on a tripod, use the Paramender (parallax correcting device) to ensure that the camera photographs the same image viewed on the focusing screen through simple operations.

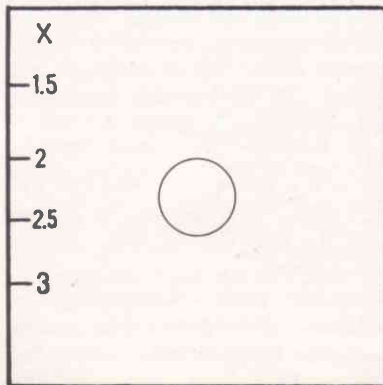

Compensating exposure:

As distance between the lens and film increases, image brightness on the film is reduced even though aperture size remains the same. Consequently, it is necessary to increase the exposure.

The figures on the focusing screen left side indicate the exposure factor. Compensate the exposure after reading the figure indicated by the pointer while focusing. For instance, assuming that the correct exposure value measured by an exposure meter is $1/125$ sec. at $f/11$, compensate the exposure as follows:

If the pointer indicates 2, $1/125$ sec., $f/8$
or $1/60$ sec., $f/11$

If the pointer indicates 3, $1/125$ sec., between $f/8$ and $f/5.6$
or $1/60$ sec., between $f/11$ and $f/8$

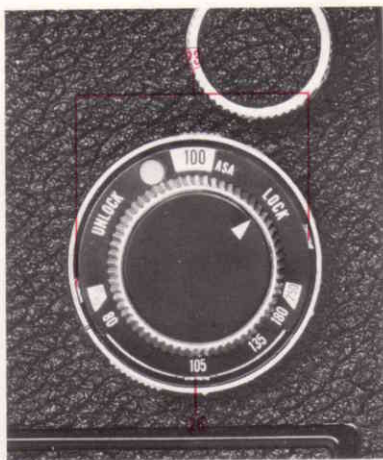

Indicating Film Speed and Type on Respective Windows

By turning the ASA indication shifting lever (23) while pushing it against the camera body, the film speed (ASA) will appear in the window. Set it to the speed of the loaded film.

By turning the film type indication select lever (26), three types of identifying marks will appear in the window. Use these marks as a film memory guide (black and white, daylight color, and tungsten type color).

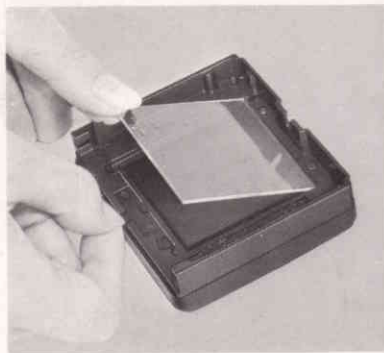

When using a 55mm or 65mm lens, set the dial (25) to 80 and attach the parallax correction plate for 55mm/65mm lenses to the focusing hood.

How to install the parallax correction plate:

Remove the focusing hood from the camera and turn it inside out. Also turn the correction plate inside out and insert its chamfered edge in the two catches on the hood, then fit the correction plate while pulling out the slide lock on the opposite side. When the slide lock is released, the plate is secured.

The figures visible on the left side of the correction plate after attaching the focusing hood to the camera reveal the exposure factor. Observe the line on the right for correcting parallax. When the pointer indicates 1.5, the upper portion of the first line will be cut off. In turn, this becomes a correcting scale when the exposure factor is 2, 2.5 and 3.

Distance Scale

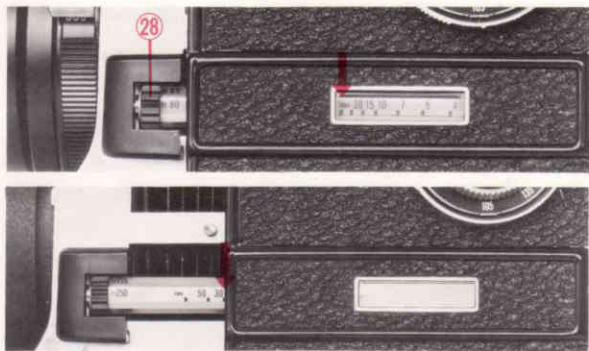

A distance scale is provided on the left side (viewing the camera held for photographing). By turning the knob (28), set the distance scale to coincide with the lens used, so that the scale faces horizontally.

Distance scales for 55mm, 65mm, and 80mm lenses are indicated in red. Read these scales at the index position in the window.

Distance scales for 105mm, 135mm, 180mm, and 250mm lenses are indicated in black. Read these scales at the front end of the camera body side plate.

Since the flange-focal length varies between the 105 mm F3.5DS or 105mm F3.5D lens and the ordinary 105mm F3.5 lens, a distance scale is especially provided.

A distance scale marked 105D.DS is used for 105mm DS and 105mmD lenses (There are two types, scaled in feet or meters.).

A distance scale marked 105 is used for ordinary 105 mm lens (There are two types, scaled in feet or meter.).

Distance graduations of lenses other than the 105mm lens are all the same.

Replacing the Distance Scale

To remove the distance scale, at first, fully extend the bellows by turning the focusing knob, then remove the scale end cover by sliding it to the front. Next, pull out the distance scale after detaching it from the bearing, by holding the distance scale revolving knob portion while pressing in the distance scale shaft with a pointed, fine wire.

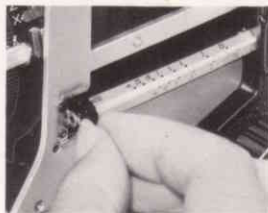
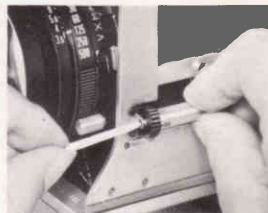
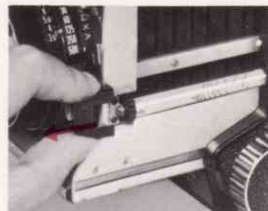

When installing the distance scale, insert the shaft tip opposite the revolving knob into the camera body bearing. In this case, insert the shaft tip while pressing the spring located near the bearing to the inner side, at the side of the scale. Next, fit the shaft to the bearing while pushing in the shaft tip with a finger nail; then install the cover as it originally was.

Taking Pictures



1. After focusing, turn the shutter speed ring (15) and set the shutter speed; then adjust the aperture of the lens by turning the aperture control knob (18). Now the camera is prepared for taking pictures.
2. Release the shutter by pressing the shutter release button (7) or (19). When a cable release is used, screw its tip into the cable release socket in the lower button (19).
3. After each exposure, wind the film by turning the film wind crank, then follow the same routine as mentioned above.

How to Remove Film

When all film frames have been exposed, the film winding stop mechanism is automatically released. Remove the film after winding the remaining leader paper on the film end.

Winding Up the Roll Film

To remove film before exposing the entire roll, or to wind up a short roll of film after exposure (6-exposure color films), turn the film wind crank while depressing the shutter button on the camera body after winding the exposed frame. In this manner, film can be completely wound without stopping.

Shutter Operations

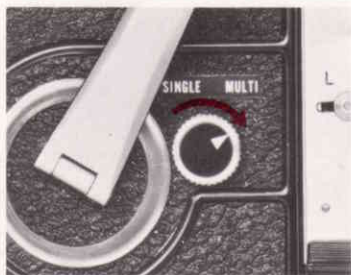
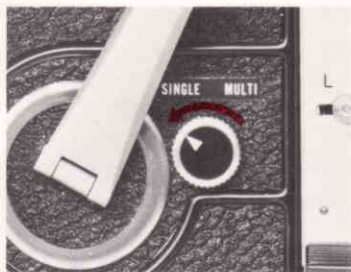

Using the Multiple Exposure Selector

When the multiple exposure selector triangular mark is set toward the word "SINGLE," double exposures are prevented. Once the shutter button has been depressed, it cannot be redepressed without first advancing the film. When the multiple exposure selector triangular mark is set toward the word "MULTI," the shutter button can be depressed repeatedly regardless of advancing film. This proves convenient in the following cases:

1. When multiple exposures are desired.
2. For operations without loaded film (such as shutter testing).
3. When photographing with the single-exposure attachment.

When photography is suspended by a missing chance to release the shutter in spite of deeply depressing the shutter button half way, it rarely happens that the shutter button cannot be depressed on the next attempt. In this case, by setting the mark on "MULTI," pictures can be taken without needlessly advancing the film.

Locking the Shutter Button

By shifting the lock button (4) toward the letter "L", the shutter button is locked. While suspending photography or the camera is stored in the case, even though the shutter has been cocked by film winding inadvertently releasing the shutter can be prevented.

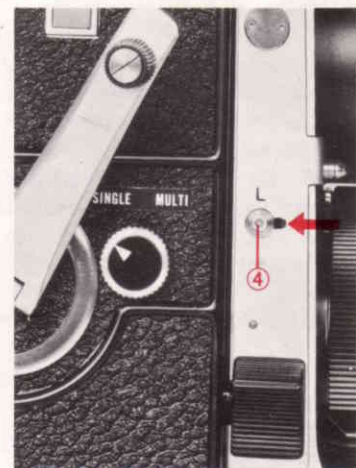

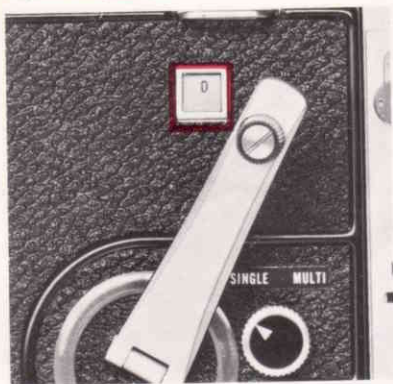

When No Film is Loaded in the Camera

Even when the film wind crank is turned, the number in the exposure counter remains at "0". In this case, if the multiple exposure button is set on "SINGLE," the shutter release button cannot be depressed. However, when a take-up spool is in the take-up spool chamber, although no film is loaded, the counter may be advanced (depending upon the type of spool). In this case, roller connected to a film will run idle, causing wear on the roller and proving undesirable to turn the film wind crank in this condition.

For certain lens-shutter assemblies, the release lever for the shutter itself can be depressed many times even though the shutter is not cocked, the same as the 80mm f/3.7 lens. (When the shutter is not cocked, the shutter blades do not open).

When using this type of lens shutter, if the shutter button is depressed without cocking the shutter, no picture will be recorded on the film. Concerning the unopened shutter blades, even though the shutter is cocked manually, the shutter button will not operate due to action of the double-exposure-preventing device. In this case, also, set the multiple exposure button triangular mark toward "MULTI" and depress the shutter button, or release the shutter by pushing the release lever on the lens-shutter assembly.



250mm f/6.3 and 80mm f/3.7 lenses:

Shutters of these lenses have no self-cocking system, requiring the shutter to be set manually after each film advance.

■ Photographing by Flash Unit



When photographing by flash, attach a flash gun to the accessory shoe (21) on the camera body and connect the cord to the flash synchro-terminal (13).

When M-class flash bulbs are used, set the synchroflash M-X selector (14) on M to synchronize flash at all shutter speeds.

When an electronic flash unit is used, set the synchroflash M-X selector on X to synchronize flash at all shutter speeds.

This synchroflash M-X selector can be changed even after cocking the shutter. When photographing without flash, keep the selector on X.

FLASH SYNCHRONIZATION TABLE

Contact	Bulb	Shutter Speed										
		B	1	$\frac{1}{2}$	$\frac{1}{4}$	$\frac{1}{8}$	$\frac{1}{15}$	$\frac{1}{30}$	$\frac{1}{60}$	$\frac{1}{125}$	$\frac{1}{250}$	$\frac{1}{500}$
M	M class	○	○	○	○	○	○	○	○	○	○	○
X	Electronic Flash	○	○	○	○	○	○	○	○	○	○	○
	F class	○	○	○	○	○	○	○	○	×	×	×
	M class	○	○	○	○	○	○	○	×	×	×	×

Combinations with the ○ mark synchronize.

Combinations with the × mark do not synchronize.

Changing Lenses

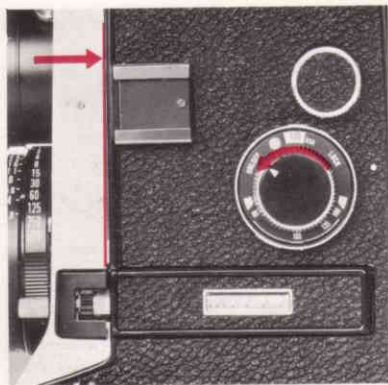

By turning the focusing knob, completely retract the bellows so that the lens mount portion contact to the body. Recess the film wind crank in the camera body.

Turn the lens change knob (24) so that the triangular mark points to the word "UNLOCK."



Tip the camera so that the lens faces upward, and while firmly grasping the lens barrel pinch the head of the lens catch bracket (20), press the head toward the camera body, push it down to release the lens catch, and remove the lens.

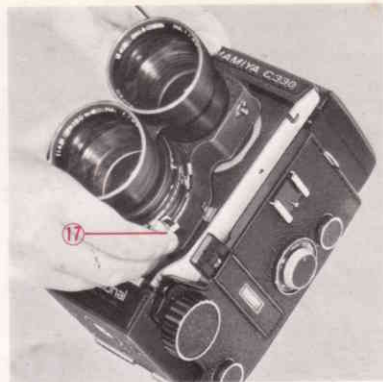

To attach another lens to the camera body, carefully position the lens so that the lens shutter cocking lever (17) connects with the cocking lever on the camera body. This operation is correctly performed by previously cocking the lens shutter with the fingers, first inserting the lens from the cocking lever side on the body. Clamp the lens catch (20) to its original position, and turn the lens change knob (24) clockwise to the "LOCK" position. With this operation, lens replacement is completed.



After changing a lens, set the parallax correcting dial (25) to the focal length value of the mounted lens. Regarding 55mm and 65mm lenses, set the parallax correcting dial to 80, then attach the parallax correction plate for 55mm/65mm lenses to the focusing hood. (Refer to p. 15 for handling method of the focusing hood).

Concerning the 250 mm lens, set the parallax correcting dial to 180.

PRECAUTIONS

1. If the film wind crank is not kept positioned diagonally upward, (the same angle as the crank housing position), the cocking lever (17) cannot be connected with the cocking lever on the camera body.
2. Regarding the cocking lever on the 180mm lens, an auxiliary lever for connection is provided on the side of the lens barrel. Since this lever is constantly pushed upward by a spring, when mounting the lens, hold the auxiliary lever downward with a finger tip to prevent obstructing installation.
3. When the lens change knob (24) is in the "UNLOCK" position, the portion to which the picture taking lens (lower lens) is attached is protected by a cover from the camera interior to shield the film from exposure to light, and a red warning signal is visible on the focusing screen surface.
Should this cover be pushed while removing the lens, light will strike the film. Never push it.
4. After changing a lens, turn the lens change knob (24) to the "LOCK" position; otherwise, the shutter release button cannot be depressed.

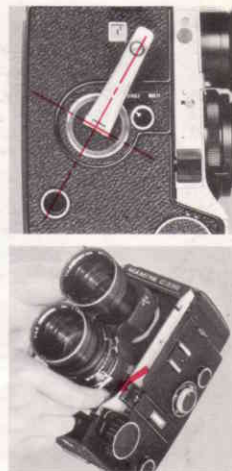

■ Changing the Back Cover

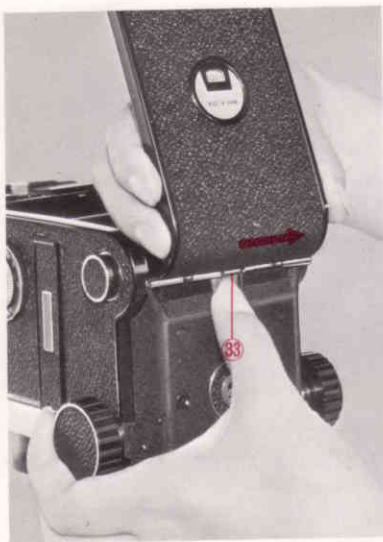

The back cover of this camera can be exchanged with the exclusive back cover for single exposure attachment. Release the back cover catch button and open the back cover halfway. In this condition, slide the back cover in the arrow direction (as shown in the picture) while depressing the back cover hinge release (33).

When the back cover is fully opened, the back cover also can be detached by sliding it horizontally while depressing the tip of the hinge release from the inner side of the back cover. When installing the back cover, press the hinge release with the hinge of the cover while inserting the hinged shaft of the back cover in the body receiver, sliding the back cover in the reverse direction from detaching it.

■ Tripod Socket

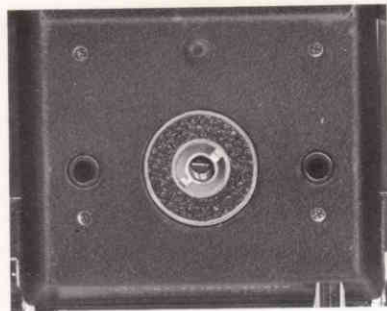

In addition to a tripod, a grip holder, pistol grip, paramender, and so forth can be attached to the tripod socket (34) on the camera base.

Those persons who own a tripod with a $3/8$ in. tripod screw can attach their tripod as follows. First, remove the securing screw located in the interior of the tripod socket with a driver, turning the screw counterclockwise. Next, fit a coin to the groove of the tripod socket and remove the tripod screw by turning it counterclockwise; thus the screw receptacle on the camera body will accept a $3/8$ in. screw.

■ Accessories

Filters

There are five different types of filters (Y2, YG, 02, UV, and SL) for each filter size described in the system chart on page 41.

- There are two different diameters for the 80mm f/2.8 and 105mm f/3.5 lenses. When you order filters for these lenses, always specify the diameter of your lens.
- When using a 49mm diameter filter, employ the 49mm filter for Mamiya C; otherwise attaching the lens hood might be impossible. When you order filters, always specify the MAMIYA C Professional type.
- To attach a filter to a lens of 49mm filter diameter, place your palm on the protective lens ring screwed into the front barrel of the lens, turn the ring counter-clockwise to remove it, and then screw in the filter. When a filter is not used, always replace the ring to protect the lens barrel.

Lens hoods

There are five different types of lens hoods available for interchangeable lenses.

1. Lens hood for 55mm lens (*)
 2. Lens hood for 65mm lens (*)
 3. Lens hood 42mm ϕ for 80mm f/2.8 (chrome type) and 105mm f/3.5 (chrome type) lenses
 4. Lens hood 48mm ϕ for 80mm f/2.8 (black type) 105mm f/3.5 D and 135mm f/4.5 lenses
 5. Lens hood for super 180mm, 180mm and 250mm lenses (*)
- Lens hoods marked with an asterisk (*) have a side plate which can be inclined. Attach the lens hood to the lens with this plate upward. When light reflected from the lens hood to the viewing lens becomes annoying while focusing, due to a certain light condition, incline the side plate to eliminate the annoying reflection.
 - All of these lens hoods are comparatively new type attached only to the taking lens. Old type lens hoods are also acceptable.

Lens cases

Seven types of hard leather cases are available for protecting the following interchangeable lenses: 55mm, 65mm, 80mm, 105mm, 135mm, 180mm, and 250mm.

Soft leather case

The soft leather case is widely applicable to protect interchangeable lenses for the Mamiya C Professional or to store accessories.

This case also can hold lenses for the Mamiya Press and Mamiya RB.

■ Accessories

Single Exposure Attachment

By using the single exposure attachment provided, single exposures can be made of dry plates (2 1/2×3 1/2 in., 6.5×9cm) or cut films (4 3/4×6 1/2 in. cut film divided into four 1/4 sizes or 2 1/2×3 1/2 in.) When using 4 3/4×6 1/2 in. cut film divided into four one-quarter sizes, use a J-type film sheath. When using 2 1/2×3 1/2 in. film, use a D-type film sheath.

Installing Method

Replace the camera back cover with the exclusive back cover for single exposure. Always remove the spool in the camera. Install a holder containing a dry plate or cut film on the exclusive back cover, closing the outer frame of the back cover to complete preparation.

PRECAUTION

Since the position of its focusing surface differs, the conventional single exposure attachment for the MAMIYA C series cannot be utilized on this camera.



Focusing Screen

The following types of focusing screen are available, replaceable according to the photographing purpose. A metal frame is provided for all focusing screens.

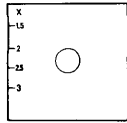
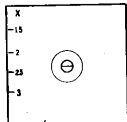
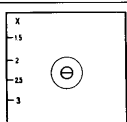
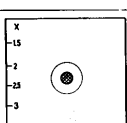
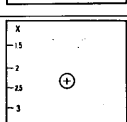
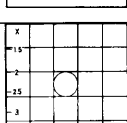
Designation	Features	Application
 <p>No. 1 Matte</p>	Matted entire surface; Fresnel lens (except center circular portion); with exposure factor scale.	For general photography Suitable for any lens
 <p>No. 2 Rangefinder Spot 4°</p>	Matted entire surface (except center small circular split prism portion); Fresnel lens (except center circular portion); with exposure factor scale.	For general photography Quick, accurate focusing is possible through the matted surface and the split prism.
 <p>No. 3 Rangefinder Spot 6°</p>	Matted entire surface (except center small circular split prism portion); with Fresnel lens (except center circular portion); with exposure factor scale.	For general photography Focusing precision by the split prism is sensitive compared with the No. 2 Rangefinder Spot 4°
 <p>No. 4 Microprism</p>	Matted entire surface (except center micropirism portion); with Fresnel lens (except center circular portion), and exposure factor scale.	For general photography Focusing is performed through the matted surface and the center microprism portion.
 <p>No. 5 Cross Hair</p>	Matted entire surface (except center circular portion); with exposure factor scale.	For special photography Suitable for close-up photography by largely extending the bellows; also for dim, distant views and astrophotography.
 <p>No. 6 Checker</p>	Matted entire surface; with Fresnel lens (except center circular portion); with sectional scale, and exposure factor scale.	Sectional graduations are added to the No. 1 Matte. Convenient in arranging composition.

Accessories

Grip holder (for Mamiya C)

The grip holder is a very convenient accessory for hand-holding the camera while taking pictures or for carrying the camera. Its accessory shoe is attached on the top of the grip.



Grip holder (for Mamiya C330 & RB)

The camera shutter can be released by triggering the shutter button of this grip. This grip can also be used for the Mamiya RB.



Pistol grip

This grip, which supports the camera from the bottom, has a trigger type shutter release button which many persons prefer when following sports action.



Magnifying Hood

This magnifying hood may be used instead of the focusing hood. By turning the knob on the side of this hood, either 3.5X or 6X magnification can be selected.



Porrofinder

By attaching this Porrofinder instead of the regular focusing hood, the camera can be held at eye level. The image in the finder is right side up and correct right to left . . . actual visual focusing.

Magnification of this finder approximately doubles the image on the ground glass focusing screen.



CdS Porrofinder

This is a Porrofinder with built-in CdS exposure meter. Match the index needles within the finder by turning the dial on the back of the finder, and read the dial scale. This device measures the amount of light traveling through the viewing lens, offering correct exposure setting even for amateurs.



Prism Finder

Through this prism finder, the image on the ground glass focusing screen appears exactly as the subject is seen. Really an indispensable accessory for eye level photo-journal photos or candid shots.

Magnification of this finder is approximately 2.5 times the image on the ground glass focusing screen, particularly bright and clear.



Eye Correction Lens

This lens, designed to correct visibility, is installed inside the eyepiece ring of the Porrofinder, CdS Porrofinder, or Prism Finder.

Nine types of lenses are provided from +2.5 to -2 diopter (each diopter is +2.5, +2.0, +1.5, +1.0, +0.5, -0.5, -1.0, -1.5, and -2.0).

When installing the lens on the finder, hold the milled portion of the eyepiece ring with the thumb and finger, and turn it counterclockwise to remove the ring. When the lens is a plus (convex) lens, position it with the flat surface outside, and when it is a minus (concave) lens, place the concave surface on the exterior, then screw the ring into its original position.

Accessories

Paramender model 2

This is a parallax-correcting instrument used between the camera base and a tripod. Keep the part attached to the camera base downward while focusing, then raise the camera position by turning the handle until it stops just before releasing the shutter. Thus, the taking lens is lifted to the position where the viewing lens was, and parallax is hereby automatically corrected.



Paramender model 3 with pan head

Model 3 Paramender supports the camera firmly with two side arms. This de luxe type Paramender also functions as the pan head.

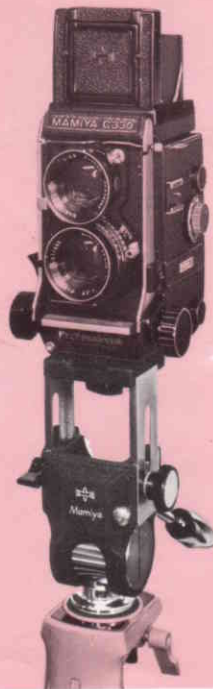

Magnifier

A very convenient accessory for accurate focusing, this magnifying glass, used by attaching it to the side plates of the focusing hood from above, magnifies the picture on the ground glass focusing screen 5.5 times. By turning the eye lens ring of the magnifier, visibility can be adjusted.



Tripod Adapter Type P

This adapter can be attached to either a U 1/4 inch or 3/8 inch tripod screw. Also this adapter permits coupling with the quick-shoe, enables rapid camera mounting on the tripod.



Focusing Knob Adapter

An adapter for attaching to the focusing knob to facilitate precise focusing.



Quick-shoe

The quick-shoe can be coupled with the tripod adapter type P, enabling the camera to be rapidly attached to the tripod.



Accessories

Flashgun Adapter

The flashgun adapter, designed for the Mamiya flashgun, is provided with an accessory shoe for accommodating other brands of clip-on type flash units.



Flashgun

Highly efficient, large BC type flashgun – usable with both a screw-base bulb and a bayonet type base bulb – supplies sufficient light for taking pictures under any condition.



Compartment Case

This compartment case is partitioned to store your Mamiya C camera mounted on the grip holder, with an interchangeable lens (except 250mm lens) and various accessories. Spare lenses can be stored separately therein.

Inner dimension :

Length:	1' 1 $\frac{1}{8}$ " (34.5 cm)
Width:	7 $\frac{1}{2}$ " (18 cm)
Depth:	5 $\frac{1}{8}$ " (15 cm)
Height of top cover:	2 $\frac{3}{4}$ " (7 cm)



■ Lens Specifications Table

Lens	Composition	Picture Angle	Minimum Aperture	Filter Diameter (mm)	Lens Hood Diameter (mm)	Close-Up Capabilities	
						Shortest Distance from Film to Subject	Subject Coverage
55mm f/4.5	9 element 7 group	70° 30'	f/22	46 ϕ	48 ϕ	9 1/2 in. (24.1cm)	2 17/32 × 2 17/32 in. (6.4 × 6.4cm)
65mm f/3.5	6 element 5 group	63°	f/32	49 ϕ	50 ϕ	10 11/16 in. (27.1cm)	2 21/32 × 2 21/32 in. (6.7 × 6.7cm)
80mm f/2.8	5 element 3 group	50° 40'	f/32	46 ϕ	48 ϕ	1ft. 1 15/16 in. (35.4cm)	3 25/64 × 3 25/64 in. (8.6 × 8.6cm)
105mm f/3.5D	5 element 3 group	41° 20'	f/32	46 ϕ	48 ϕ	1ft. 11in. (58.4cm)	7 1/4 × 7 1/4 in. (18.4 × 18.4cm)
135mm f/4.5	4 element 3 group	33°	f/45	46 ϕ	48 ϕ	2ft. 11 1/2 in. (90.2cm)	9 15/16 × 9 15/16 in. (25.2 × 25.2cm)
Super 180mm f/4.5	5 element 4 group	24° 30'	f/45	49 ϕ	50 ϕ	4ft. 2 3/4 in. (1m29cm)	10 53/64 × 10 53/64 in. (27.5 × 27.5cm)
250mm f/6.3	6 element 4 group	18°	f/64	49 ϕ	50 ϕ	6ft. 8 3/4 in. (2m05cm)	1ft. 1/4in. × 1ft. 1/4in. (31.1 × 31.1cm)

■ Angle of View Changes by Interchanging Lenses

All these pictures were taken from the same position, at an identical distance from the subject.

55mm



65mm



80mm



105mm



135mm



180mm



250mm



■ Depth of Field Table

55mm f/4.5

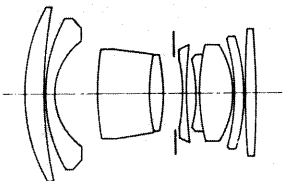

Aperture	Distance (in feet)										
	∞	30	15	7	5	3	2.5	2	1.5	1	9/2'
4.5	29' 1" ∞	14' 11" ∞	10' 30' 1'	5' 9"	4' 4 1/4" 5' 11"	2' 9 3/4" 3' 3 3/4"	2' 4 3/8" 2' 8 3/4"	1' 10 1/8" 2' 1 1/4"	1' 5 3/4" 1' 6 1/2"	11 3/4" 1' 1/4"	9 3/8" 9 3/8"
5.6	23' 2" ∞	13' 3" ∞	9' 3" 40' 8"	5' 6" 9' 8 1/2"	4' 2 1/2" 6' 2"	2' 8 1/2" 3' 4 3/4"	2' 4 1/4" 2' 9 1/2"	1' 10 5/8" 2' 1 1/2"	1' 5 3/4" 1' 6 3/4"	11 3/4" 1' 3/8"	9 3/8" 9 3/8"
8	16' 5" ∞	10' 9" ∞	8' 145'	5' 1" 11' 7"	3' 11 1/2" 6' 10"	2' 7 1/2" 3' 6 3/4"	2' 3 3/8" 2' 10 3/4"	1' 10 1/8" 2' 2 1/4"	1' 5 3/4" 1' 7"	11 3/4" 1' 1/4"	9 3/8" 9 3/8"
11	11' 8" ∞	8' 6" ∞	6' 9" ∞	4' 6 1/2" 16' 1"	3' 7 3/4" 8' 2"	2' 5 1/2" 3' 9 3/4"	2' 2 1/4" 3' 3/4"	1' 9 3/4" 2' 3 3/4"	1' 4 3/4" 1' 7 1/2"	11 3/4" 1' 3/8"	9 3/8" 9 3/8"
16	8' 4" ∞	6' 8" ∞	5' 6" ∞	3' 11 1/4" 35' 10"	3' 3 1/2" 11' 1"	2' 4 1/4" 4' 3 3/4"	2' 7/8" 3' 4 1/4"	1' 8 3/8" 2' 5"	1' 4 3/4" 1' 8 3/4"	11 3/4" 1' 5/8"	9 3/8" 9 3/8"
22	5' 11 1/2" ∞	5' 1" ∞	4' 5" ∞	3' 4 3/4" ∞	2' 10 3/4" 23' 8"	2' 1 1/4" 5' 1"	1' 11 1/8" 3' 10 3/4"	1' 7 3/4" 2' 7 3/4"	1' 3 3/4" 1' 9 3/4"	11 3/4" 1' 7/8"	9 3/8" 9 3/8"

Aperture	Distance (in meter)											
	∞	5	3	2	1.5	1.1	0.8	0.6	0.5	0.4	0.3	0.25
4.5	8.87 ∞	3.24 11.11	2.28 4.42	1.66 2.52	1.31 1.76	1.00 1.23	0.75 0.86	0.57 0.63	0.48 0.52	0.391 0.410	0.296 0.304	0.249 0.251
5.6	7.07 ∞	2.98 16.28	2.15 5.04	1.59 2.70	1.27 1.85	0.98 1.26	0.74 0.88	0.57 0.64	0.48 0.52	0.389 0.412	0.296 0.305	0.248 0.252
8	5.02 ∞	2.56 ∞	1.93 7.04	1.47 3.17	1.19 2.05	0.93 1.35	0.71 0.91	0.56 0.65	0.47 0.53	0.384 0.418	0.294 0.307	0.248 0.253
11	3.57 ∞	2.13 ∞	1.68 16.81	1.33 4.21	1.10 2.42	0.88 1.49	0.68 0.97	0.54 0.68	0.46 0.55	0.378 0.425	0.291 0.309	0.247 0.254
16	2.55 ∞	1.73 ∞	1.43 ∞	1.17 7.97	0.99 3.27	0.81 1.76	0.65 1.07	0.52 0.72	0.45 0.57	0.370 0.437	0.288 0.314	0.245 0.255
22	1.82 ∞	1.37 ∞	1.18 ∞	1.00 ∞	0.87 6.65	0.73 2.37	0.60 1.25	0.49 0.79	0.43 0.61	0.359 0.455	0.283 0.320	0.243 0.257

Depth of Field Table

65mm f/3.5

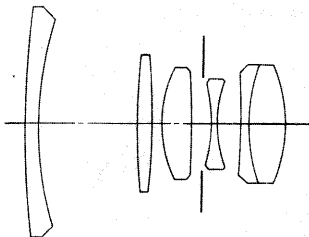

Aperture	Distance (in feet)										
	∞	30	15	7	5	3	2	1.75	1.5	1.25	1
3.5	50' 2 3/4" ∞	18' 11 3/4" 73' 1 3/4"	11' 8" 21' 1"	6' 2 1/2" 8' 3/4"	4' 7 1/4" 5' 5 3/4"	2' 10 1/2" 3' 1 3/4"	1' 11 1/4" 2' 1/2"	1' 8 3/4" 1' 9 3/4"	1' 5 3/4" 1' 6 3/4"	1' 2 3/4" 1' 3 3/4"	11 3/8" 1' 3/8"
4	43' 11 1/2" ∞	17' 11 3/4" 92' 1 3/4"	11' 3 3/4" 22' 4 1/2"	6' 1 1/2" 8' 2 3/4"	4' 6 1/2" 5' 6 3/4"	2' 10 1/4" 3' 2"	1' 11 1/4" 2' 3/4"	1' 8 1/4" 1' 9 3/4"	1' 5 1/4" 1' 6 1/4"	1' 2 1/4" 1' 3 1/4"	11 1/8" 1' 1/8"
5.6	31' 5 1/2" ∞	15' 6 3/4" 155' 9"	10' 3 3/4" 27' 11"	5' 9 3/4" 8' 9 3/4"	4' 4 3/4" 5' 9 3/4"	2' 9 3/4" 3' 3"	1' 11" 2' 1"	1' 8 1/4" 1' 9 3/4"	1' 5 1/4" 1' 6 1/4"	1' 2 1/4" 1' 3 1/4"	11 1/8" 1' 1/8"
8	22' 1" ∞	12' 10 1/2" ∞	9' 1" 44' 5 3/4"	5' 5 1/4" 9' 11"	4' 2" 6' 3"	2' 8 1/2" 3' 4 1/2"	1' 10 1/2" 2' 1 1/2"	1' 8" 1' 10 1/2"	1' 5 1/4" 1' 6 1/4"	1' 2 1/4" 1' 3 1/4"	11 3/8" 1' 3/8"
11	16' 1 1/2" ∞	10' 7 1/2" ∞	7' 11 1/4" 175' 8"	5' 3/4" 11' 9 3/4"	3' 11 1/4" 6' 11"	2' 7 1/2" 3' 6 1/4"	1' 10 1/4" 2' 2 1/2"	1' 7 3/4" 1' 10 1/2"	1' 5 1/4" 1' 7 1/2"	1' 2 1/4" 1' 3 1/4"	11 1/8" 1' 1/8"
16	11' 1 3/4" ∞	8' 3" ∞	6' 6 3/4" ∞	4' 5 1/2" 17' 2 1/4"	3' 7 3/4" 8' 5"	2' 5 3/4" 3' 10 1/4"	1' 9 3/4" 2' 3 3/4"	1' 7 3/4" 1' 11 1/2"	1' 4 3/4" 1' 7 3/4"	1' 2 1/4" 1' 3 1/4"	11 3/8" 1' 3/8"
22	8' 2" ∞	6' 6 3/4" ∞	5' 5 1/4" ∞	3' 11 1/4" 39' 3/4"	3' 3" 11' 5"	2' 4" 4' 3 3/4"	1' 8 3/4" 2' 5"	1' 6 3/4" 2' 5 1/2"	1' 4 3/4" 1' 8 3/4"	1' 1 3/4" 1' 4 3/4"	11 3/8" 1' 1/8"
32	5' 8 3/4" ∞	4' 10 3/4" ∞	4' 3" ∞	3' 3 3/4" ∞	2' 10" 29' 3/4"	2' 1 1/2" 5' 5 1/4"	1' 7 1/4" 2' 8 1/4"	1' 5 3/4" 2' 2 1/2"	1' 3 3/4" 1' 9 3/4"	1' 1 3/4" 1' 4 3/4"	11 3/8" 1' 1/8"

Aperture	Distance (in meter)											
	∞	5	3	2	1.2	1	0.8	0.65	0.6	0.5	0.4	0.3
3.5	15.31 ∞	3.81 7.32	2.54 3.68	1.79 2.27	1.12 1.29	0.95 1.06	0.77 0.83	0.63 0.67	0.585 0.616	0.490 0.510	0.395 0.405	0.298 0.302
4	13.40 ∞	3.68 7.84	2.48 3.80	1.76 2.31	1.12 1.30	0.94 1.06	0.77 0.84	0.63 0.67	0.582 0.619	0.489 0.512	0.394 0.406	0.298 0.302
5.6	9.59 ∞	3.33 10.16	2.32 4.26	1.68 2.47	1.09 1.34	0.92 1.09	0.75 0.85	0.62 0.68	0.576 0.627	0.485 0.517	0.392 0.409	0.297 0.303
8	6.73 ∞	2.92 18.35	2.12 5.21	1.58 2.75	1.04 1.42	0.89 1.14	0.73 0.88	0.61 0.70	0.566 0.639	0.478 0.524	0.388 0.413	0.296 0.304
11	4.91 ∞	2.53 7.25	1.91 3.21	1.46 3.21	1.00 1.52	0.86 1.20	0.71 0.92	0.59 0.72	0.554 0.655	0.471 0.534	0.384 0.418	0.294 0.306
16	3.40 ∞	2.07 ∞	1.64 20.27	1.31 4.30	0.93 1.73	0.81 1.33	0.68 0.98	0.57 0.75	0.536 0.684	0.459 0.551	0.378 0.426	0.292 0.309
22	2.49 ∞	1.71 ∞	1.41 ∞	1.16 8.48	0.85 2.09	0.76 1.52	0.64 1.07	0.55 0.80	0.516 0.723	0.446 0.573	0.370 0.437	0.289 0.313
32	1.73 ∞	1.32 ∞	1.14 ∞	0.98 ∞	0.76 3.21	0.68 2.00	0.59 1.28	0.51 0.91	0.486 0.801	0.425 0.616	0.358 0.457	0.284 0.319

80mm f/2.8

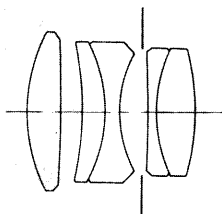

Aperture	Distance (in feet)								
	∞	30	15	10	7	5	4	3	1.5
2.8	102' 7" ∞	23' 4 1/4" 42' 1/4"	13' 2" 17' 5"	9' 2" 11'	6' 7 1/2" 7' 5 1/2"	4' 9 3/4" 5' 2 1/2"	3' 10 1/2" 4' 1 1/2"	2' 11 1/4" 3' 3/4"	1' 5 1/2" 1' 6 1/2"
4	71' 10 1/2" ∞	21' 4" 50' 9 3/4"	12' 6 1/4" 18' 8 3/4"	8' 10 1/2" 11' 5 3/4"	6' 5 1/4" 7' 8"	4' 8 3/4" 5' 3 3/4"	3' 10" 4' 2 1/4"	2' 11" 3' 1 1/4"	1' 5 3/2" 1' 6 3/2"
5.6	51' 5" ∞	19' 1 1/2" 70' 4"	11' 9" 20' 9 1/2"	8' 5 1/4" 12' 2 1/2"	6' 3" 7' 11 3/4"	4' 7 1/2" 5' 5 1/2"	3' 9 1/4" 4' 3 3/4"	2' 10 1/2" 3' 1 1/2"	1' 5 3/2" 1' 6 3/2"
8	36' 3/4" ∞	16' 7" 167' 5 3/4"	10' 9 1/4" 24' 11 1/2"	7' 11 1/2" 13' 5 3/4"	5' 11 3/4" 8' 5 3/4"	4' 5 3/4" 5' 8"	3' 8" 4' 4 3/4"	2' 10" 3' 2 1/4"	1' 5 3/2" 1' 6 3/2"
11	26' 3 1/2" ∞	14' 2 1/2" ∞	9' 8 3/4" 33' 3 3/4"	7' 5" 15' 6 1/2"	5' 8" 9' 2 1/2"	4' 3 3/4" 5' 11 3/4"	3' 6 3/4" 4' 6 3/4"	2' 9 1/4" 3' 3 3/4"	1' 5 3/2" 1' 6 3/2"
16	18' 1 3/4" ∞	11' 6" ∞	8' 5" 76' 3 3/4"	6' 7 1/2" 20' 10 1/4"	5' 2 1/2" 10' 9 1/2"	4' 3" 6' 6 3/4"	3' 4 3/4" 4' 10 1/2"	2' 8" 3' 5"	1' 5 1/2" 1' 6 3/2"
22	13' 3 3/4" ∞	9' 4 1/2" ∞	7' 3" ∞	5' 10 3/4" 35' 8"	4' 9 1/4" 13' 7"	3' 9 1/2" 7' 5 3/4"	3' 2 3/4" 5' 4"	2' 7" 3' 7 1/2"	1' 5 1/2" 1' 7"
32	9' 2 1/4" ∞	7' 2 1/4" ∞	5' 10 3/4" ∞	5" ∞	4' 2 1/4" 24' 2 3/4"	3' 5 1/4" 9' 7 3/4"	2' 11 1/2" 6' 3 3/4"	2' 5" 4'	1' 4 3/2" 1' 7 1/2"

Aperture	Distance (in meter)								
	∞	10	5	3	2	1.5	1.2	1	0.45
2.8	31.27 ∞	7.62 14.57	4.34 5.90	2.76 3.29	1.89 2.12	1.44 1.56	1.16 1.24	0.98 1.02	0.447 0.453
4	21.91 ∞	6.92 18.13	4.11 6.40	2.66 3.44	1.85 2.18	1.42 1.59	1.15 1.26	0.97 1.04	0.446 0.454
5.6	15.67 ∞	6.16 26.92	3.84 7.21	2.55 3.65	1.80 2.26	1.39 1.63	1.13 1.28	0.95 1.05	0.444 0.456
8	10.99 ∞	5.30 99.80	3.49 8.91	2.40 4.02	1.72 2.39	1.35 1.70	1.10 1.32	0.94 1.07	0.442 0.458
11	8.01 ∞	4.51 ∞	3.14 12.65	2.23 4.62	1.64 2.57	1.30 1.78	1.07 1.37	0.91 1.11	0.439 0.462
16	5.53 ∞	3.62 ∞	2.69 42.83	2.00 6.14	1.52 2.97	1.22 1.96	1.02 1.46	0.88 1.16	0.434 0.467
22	4.04 ∞	2.93 ∞	2.30 ∞	1.78 10.25	1.39 3.64	1.14 2.21	0.97 1.59	0.84 1.24	0.429 0.474
32	2.80 ∞	2.23 ∞	1.85 ∞	1.51 ∞	1.23 5.90	1.04 2.84	0.89 1.87	0.79 1.40	0.420 0.486

Depth of Field Table

105mm f/3.5 D

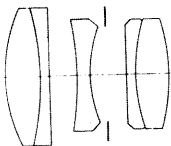

Aperture	Distance (in feet)								
	∞	30	15	10	7	5	4.5	4	3
3.5	131' 5¼"	24' 7"	13' 6¾"	9' 4¼"	6' 8¾"	4' 10¼"	4' 4¼"	3' 11"	2' 11½"
	∞	38' 6½"	16' 9½"	10' 8¾"	7' 4"	5' 2"	4' 7½"	4' 1"	3' ¾"
4	115' ½"	23' 11½"	13' 4½"	9' 3¼"	6' 7¾"	4' 10"	4' 4¼"	3' 10¾"	2' 11½"
	∞	40' 2"	17' 1"	10' 10¼"	7' 4½"	5' 2¼"	4' 7¾"	4' 1¼"	3' ¾"
5.6	82' 3¼"	22' 2¼"	12' 9¾"	9' ¼"	6' 6¾"	4' 9¼"	4' 3¾"	3' 10¼"	2' 11½"
	∞	46' 6¾"	18' 1¼"	11' 2¾"	7' 6¾"	5' 3"	4' 8½"	4' 1¾"	3' ¾"
8	57' 8¼"	19' 11¾"	12' 1"	8' 7¾"	6' 4"	4' 8¾"	4' 3"	3' 9¾"	2' 10¾"
	∞	60' 11¾"	19' 10½"	11' 10½"	7' 9¾"	5' 4½"	4' 9¾"	4' 2¾"	3' 1½"
11	42' ½"	17' 9¾"	11' 3"	8' 3"	6' 1½"	4' 6¾"	4' 2"	3' 8¾"	2' 10¾"
	∞	100' ½"	22' 7¾"	12' 9¾"	8' 2¼"	5' 6¾"	4' 11"	4' 3¾"	3' 1½"
16	28' 11½"	15"	10' 1½"	7' 7¾"	5' 9¾"	4' 4¾"	4' ¼"	3' 7¾"	2' 9¾"
	∞	∞	29' 7"	14' 7½"	8' 10½"	5' 9¾"	5' 1½"	4' 5½"	3' 2¼"
22	21' 2¼"	12' 8"	9' ½"	7' ¾"	5' 5½"	4' 2¾"	3' 10½"	3' 6"	2' 8¾"
	∞	∞	38' 6½"	17' 9"	9' 10½"	6' 2¼"	5' 5"	4' 8"	3' 3¾"
32	14' 8"	10' 1"	7' 8¾"	6' 2½"	4' 11¾"	3' 11¾"	3' 7¾"	3' 4"	2' 7¾"
	∞	∞	5180' 3¼"	27' 9¾"	12' 2¼"	6' 11¾"	5' 11¾"	4' ¾"	3' 5¾"

Aperture	Distance (in meter)									
	∞	10	5	3	2	1.5	1.3	1.2	1	0.65
3.5	40.06	8.05	4.48	2.81	1.92	1.46	1.27	1.17	0.98	0.645
	∞	13.21	5.67	3.22	2.09	1.55	1.33	1.23	1.02	0.655
4	35.07	7.84	4.41	2.79	1.91	1.45	1.26	1.17	0.98	0.644
	∞	13.85	4.78	3.25	2.10	1.55	1.34	1.23	1.02	0.656
5.6	25.08	7.21	4.21	2.71	1.87	1.43	1.25	1.16	0.97	0.642
	∞	16.38	6.16	3.36	2.15	1.58	1.35	1.24	1.03	0.659
8	17.58	6.45	3.95	2.60	1.83	1.41	1.23	1.14	0.96	0.638
	∞	22.59	6.85	3.55	2.21	1.61	1.38	1.26	1.04	0.663
11	12.82	5.70	3.66	2.48	1.77	1.37	1.21	1.12	0.95	0.634
	∞	43.09	7.96	3.81	2.31	1.66	1.41	1.29	1.06	0.667
16	8.84	4.77	3.27	2.30	1.68	1.32	1.17	1.09	0.93	0.627
	∞	∞	10.92	4.35	2.48	1.74	1.47	1.34	1.09	0.676
22	6.46	4.00	2.90	2.12	1.59	1.27	1.13	1.07	0.90	0.618
	∞	∞	19.91	5.26	2.74	1.85	1.54	1.40	1.12	0.686
32	4.47	3.16	2.44	1.87	1.45	1.19	1.07	1.00	0.87	0.605
	∞	∞	∞	8.08	3.30	2.08	1.69	1.51	1.19	0.704

135mm f/4.5

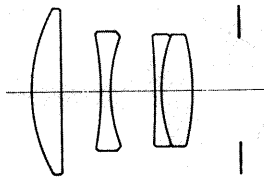

Aperture	Distance (in feet)								
	∞	30	15	10	7	6	4	3.5	3
4.5	159' 3½" ∞	25' 4¾" 36' 8"	13' 9½" 16' 5¾"	9' 5¾" 10' 7"	6' 9" 7' 3¾"	5' 10" 6' 2¾"	3' 11¼" 4' ¾"	3' 5¾" 3' 6¾"	2' 11¼" 3' ½"
5.6	128' ¾" ∞	24' 5¾" 38' 9¾"	13' 6½" 16' 10"	9' 4¼" 10' 9"	6' 8¼" 7' 4"	5' 9½" 6' 2¾"	3' 11" 4' 1"	3' 5¼" 3' 6¾"	2' 11½" 3' ½"
8	89' 8¾" ∞	22' 8½" 44' 4¼"	13' 17' 9"	9' 1¼" 11' 1¼"	6' 7" 7' 5¼"	5' 8¼" 6' 4"	3' 10½" 4' 1½"	3' 5" 3' 7"	2' 11¼" 3' ¾"
11	65' 4" ∞	20' 9¾" 54' 1¼"	12' 4½" 19' 1"	8' 9¾" 11' 9"	6' 5¼" 7' 8¼"	5' 7" 6' 5¼"	3' 10" 4' 2¼"	3' 4¾" 3' 7½"	2' 11" 3' 1"
16	45' ¼" ∞	18' 3½" 85' 6¾"	11' 5¾" 21' 9½"	8' 4¼" 12' 5¾"	6' 2½" 8' ¾"	5' 5" 6' 8¾"	3' 9¼" 4' 3¼"	3' 4" 3' 8¼"	2' 10¾" 3' 1½"
22	32' 10" ∞	15' 11¾" 286' 2¾"	10' 6¾" 26' 3½"	7' 10½" 13' 9¼"	5' 11¼" 8' 6¾"	5' 2¾" 7' ¾"	3' 8¼" 4' 4¾"	3' 3¼" 3' 9¼"	2' 10¼" 3' 2"
32	22' 8" ∞	13' 2¼" ∞	9' 3¾" 40' 2¾"	7' 2¼" 16' 8"	5' 6¾" 9' 6"	4' 11¼" 7' 8"	3' 6¾" 4' 7"	3' 2¼" 3' 10¾"	2' 9¼" 3' 3¾"
45	16' 2½" ∞	10' 9½" ∞	8' 1" 132' 8"	6' 5¾" 23' ½"	5' 1¼" 11' 2"	4' 7¾" 8' 8¼"	3' 5" 4' 10½"	3' ¾" 4' 3¾"	2' 8¾" 3' 4¾"

Aperture	Distance (in meter)								
	∞	10	5	3	2	1.75	1.2	1.0	0.95
4.5	48.55 ∞	8.34 12.49	4.56 5.53	2.85 3.17	1.93 2.07	1.70 1.80	1.18 1.22	0.99 1.01	0.94 0.96
5.6	39.03 ∞	8.02 13.30	4.47 5.68	2.81 3.22	1.92 2.09	1.69 1.81	1.17 1.23	0.98 1.02	0.94 0.96
8	27.35 ∞	7.39 15.51	4.27 6.03	2.74 3.32	1.89 2.13	1.67 1.84	1.16 1.24	0.98 1.02	0.93 0.97
11	19.92 ∞	6.74 19.56	4.05 6.54	2.65 3.46	1.85 2.18	1.64 1.88	1.15 1.25	0.97 1.03	0.92 0.98
16	13.72 ∞	5.87 34.79	3.74 7.61	2.52 3.73	1.79 2.28	1.59 1.95	1.13 1.28	0.96 1.05	0.91 0.99
22	10.01 ∞	5.09 566.22	3.41 9.49	2.37 4.10	1.72 2.40	1.54 2.04	1.11 1.31	0.94 1.07	0.90 1.01
32	6.91 ∞	4.17 ∞	2.99 16.18	2.17 4.94	1.62 2.65	1.46 2.21	1.07 1.37	0.92 1.10	0.88 1.04
45	4.94 ∞	3.39 ∞	2.58 217.48	1.95 6.75	1.50 3.05	1.37 2.47	1.03 1.46	0.89 1.15	0.85 1.08

Depth of Field Table

**Super
180mm f/4.5**

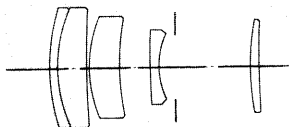

Aperture	Distance (in feet)										
	∞	60	30	15	12	10	8	7	6	5	4.5
4.5	299' ∞	50' 2" 74' 8"	27' 4 1/2" 33' 2 1/4"	14' 4 1/4" 15' 8 1/2"	11' 7" 12' 5 1/4"	9' 8 3/4" 10' 3 3/4"	7' 10" 8' 2 1/4"	6' 10 1/2" 7' 1 1/2"	5' 11" 6' 1"	4' 11 1/4" 5' 3/4"	4' 5 1/2" 4' 6 1/2"
5.6	240' ∞	48' 3" 79' 5"	26' 9 3/4" 34' 3/4"	14' 2 1/2" 15' 10 3/4"	11' 6" 12' 6 1/2"	9' 8" 10' 4 1/2"	7' 9 1/2" 8' 2 3/4"	6' 10" 7' 2"	5' 10 3/4" 6' 1 1/4"	4' 11 1/4" 5' 1"	4' 5 1/4" 4' 6 3/4"
8	168' ∞	44' 6" 92' 3"	25' 7 3/4" 36' 2"	13' 10 1/2" 16' 3 3/4"	11' 3 1/2" 12' 9 3/4"	9' 6 1/4" 10' 6 1/2"	7' 8 1/2" 8' 3 3/4"	6' 9 1/4" 7' 2 1/4"	5' 10 1/4" 6' 2"	4' 10 3/4" 5' 1 1/4"	4' 5' 4' 7"
11	122' ∞	40' 7" 115' 7"	24' 4" 39' 2 1/4"	13' 6" 16' 10 1/2"	11' 1/2" 13' 1 1/2"	9' 4 1/4" 10' 9"	7' 7 1/4" 8' 5 1/2"	6' 1/2" 7' 4"	5' 9 1/2" 6' 2 3/4"	4' 10 1/4" 5' 1 3/4"	4' 4 3/4" 4' 7 1/4"
16	84' 2" ∞	35' 5" 200'	22' 4 3/4" 45' 6 1/2"	12' 11" 17' 10 3/4"	10' 8" 13' 8 3/4"	9' 1" 11' 1 1/2"	7' 5" 8' 8"	6' 6 3/4" 7' 6"	5' 8 3/4" 6' 4"	4' 9 3/4" 5' 2 1/2"	4' 4 3/4" 4' 8 1/4"
22	61' 3" ∞	30' 8" 166 4'	20' 5 1/2" 56' 7"	12' 3 3/4" 19' 3 3/4"	10' 3" 14' 6 3/4"	8' 9 3/4" 11' 7 1/2"	7' 2 3/4" 8' 11 1/2"	6' 5" 7' 8 3/4"	5' 7" 6' 5 3/4"	4' 8 3/4" 5' 3 1/2"	4' 3 3/4" 4' 8 3/4"
32	42' 3" ∞	25' 2" ∞	17' 10 3/4" 95' 2"	11' 4 1/4" 22' 2 1/2"	9' 7 3/4" 16' 1/2"	8' 3 3/4" 12' 6 3/4"	6' 11 1/4" 9' 5 3/4"	6' 2 3/4" 8' 3/4"	5' 5" 6' 8 3/4"	4' 7 1/2" 5' 5 1/2"	4' 2 3/4" 4' 10"
45	30' 1" ∞	20' 4" ∞	15' 4 3/4" 87 4'	10' 4 1/4" 27' 8"	8' 10 3/4" 18' 7 1/2"	7' 9 1/2" 14' 1/2"	6' 7" 10' 3"	5' 11" 8' 7 3/4"	5' 2 3/4" 7' 3/4"	4' 5 3/4" 5' 8"	4' 1 1/4" 5'

Aperture	Distance (in meter)											
	∞	20	10	7	5	4	3	2.5	2	1.7	1.5	1.3
4.5	91.00 ∞	16.46 25.49	9.05 11.18	6.53 7.94	4.76 5.26	3.85 4.16	2.92 3.09	2.45 2.56	1.97 2.03	1.68 1.72	1.48 1.52	1.29 1.31
5.6	73.14 ∞	15.78 27.32	8.84 11.51	6.42 7.69	4.71 5.33	3.81 4.20	2.90 3.11	2.43 2.57	1.96 2.04	1.67 1.73	1.48 1.52	1.29 1.31
8	51.22 ∞	14.47 32.42	8.43 12.30	6.21 8.03	4.59 5.49	3.74 4.30	2.86 3.16	2.40 2.60	1.94 2.06	1.66 1.74	1.47 1.53	1.28 1.32
11	37.27 ∞	13.12 42.28	7.96 13.34	5.95 8.50	4.46 5.70	3.65 4.42	2.81 3.22	2.37 2.65	1.92 2.09	1.65 1.76	1.46 1.54	1.27 1.33
16	25.65 ∞	11.35 85.96	7.29 16.00	5.58 9.42	4.25 6.09	3.51 4.65	2.73 3.33	2.32 2.72	1.89 2.13	1.62 1.79	1.44 1.56	1.26 1.34
22	18.68 ∞	9.77 20.67	6.62 20.67	5.18 10.84	4.02 6.63	3.36 4.95	2.64 3.48	2.25 2.81	1.85 2.18	1.59 1.82	1.42 1.59	1.25 1.36
32	12.87 ∞	7.94 ∞	5.74 40.37	4.64 14.46	3.69 7.79	3.14 5.55	2.50 3.75	2.16 2.98	1.79 2.28	1.55 1.88	1.39 1.63	1.22 1.39
45	9.17 ∞	6.39 ∞	4.90 ∞	4.08 25.69	4.08 10.10	3.34 6.60	2.88 4.18	2.35 3.23	2.04 2.41	1.71 1.97	1.50 1.69	1.35 1.43

250mm f/6.3

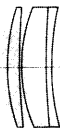

Aperture	Distance (in feet)										
	∞	200	100	50	30	20	15	12	10	8	7
6.3	412'	135'	81'	44' 11"	28' 2"	19' 2"	14' 7"	11' 9"	9' 10"	7' 11"	6' 11½"
	∞	385'	131'	56' 5"	32' 1"	20' 10"	15' 5"	12' 3"	10' 2"	8' 1"	7' ½"
8	325'	125'	77'	43' 8"	27' 8"	19'	14' 5"	11' 8"	9' 9½"	7' 10½"	6' 11"
	∞	513'	143'	58' 6"	32' 8"	21' 1"	15' 7"	12' 4"	10' 2"	8' 1½"	7' 1"
11	230'	108'	70' 4"	41' 6"	26' 10"	18' 7"	14' 3"	11' 6"	9' 8½"	7' 10"	6' 10½"
	∞	1474'	174'	62' 11"	34'	21' 7"	15' 10"	12' 6"	10' 3"	8' 2"	7' 1½"
16	163'	90' 7"	62' 9"	38' 10"	25' 9"	18' 1"	14'	11' 3"	9' 7"	7' 9"	6' 10"
	∞	∞	252'	70' 6"	36'	22' 4"	16' 2"	12' 8"	10' 5"	8' 3"	7' 2"
22	116'	74'	54' 5"	35' 7"	24' 4"	17' 5"	13' 7"	11' 2"	9' 5"	7' 8"	6' 9"
	∞	∞	688'	85' 2"	39' 3"	23' 6"	16' 9"	13'	10' 8"	8' 4½"	7' 2½"
32	82' 1"	58' 10"	45' 11"	31' 10"	22' 7"	16' 7"	13' 1"	10' 10"	9' 2½"	7' 6½"	6' 8"
	∞	∞	∞	121'	45' 2"	25' 4"	17' 7"	13' 7"	10' 11"	8' 6"	7' 4"
45	58' 5"	45' 9"	37' 7"	27' 9"	20' 6"	15' 6"	12' 5"	10' 5"	8' 11½"	7' 4½"	6' 6½"
	∞	∞	∞	303'	57' 6"	28' 7"	19'	14' 3"	11' 4"	8' 9"	7' 6"
64	41' 8"	34' 11"	30' 1"	23' 6"	18' 3"	14' 3"	11' 8"	9' 10½"	8' 6½"	7' 1½"	6' 4½"
	∞	∞	∞	∞	94' 4"	34' 11"	21' 5"	15' 6"	12' 1"	9' 1½"	7' 9"

Aperture	Distance (in meter)										
	∞	50	30	20	15	10	7	5	4	3	2.5
6.3	125.6	35.97	24.37	17.37	13.49	9.33	6.68	4.84	3.91	2.95	2.47
	∞	82.30	39.08	23.59	16.90	10.78	7.36	5.17	4.10	3.05	2.53
8	99.02	33.44	23.20	16.78	13.14	9.16	6.60	4.80	3.88	2.94	2.46
	∞	99.75	42.57	24.80	17.50	11.01	7.46	5.21	4.13	3.06	2.54
11	70.12	29.43	21.22	15.73	12.50	8.86	6.45	4.73	3.83	2.92	2.45
	∞	170.3	51.56	27.55	18.80	11.49	7.67	5.31	4.18	3.09	2.56
16	49.69	25.17	18.94	14.46	11.70	8.46	6.24	4.62	3.77	2.88	2.42
	∞	∞	73.65	32.70	21.02	12.26	7.98	5.45	4.27	3.13	2.58
22	35.24	20.91	16.45	12.99	10.73	7.96	5.98	4.49	3.68	2.84	2.39
	∞	∞	188.4	44.55	25.26	13.54	8.48	5.66	4.39	3.19	2.62
32	25.03	16.90	13.89	11.36	9.61	7.35	5.64	4.31	3.57	2.77	2.35
	∞	∞	∞	92.02	3.55	15.91	9.31	5.99	4.57	3.28	2.67
45	17.81	13.32	11.41	9.67	8.39	6.63	5.23	4.08	3.42	2.69	2.30
	∞	∞	∞	∞	83.74	21.20	10.82	6.54	4.86	3.41	2.75
64	12.70	10.29	9.13	8.00	7.13	5.84	4.74	3.79	3.23	2.58	2.23
	∞	∞	∞	∞	∞	40.55	14.09	7.54	5.36	3.62	2.87

www.bukus.us

System Chart for Mamiya C330

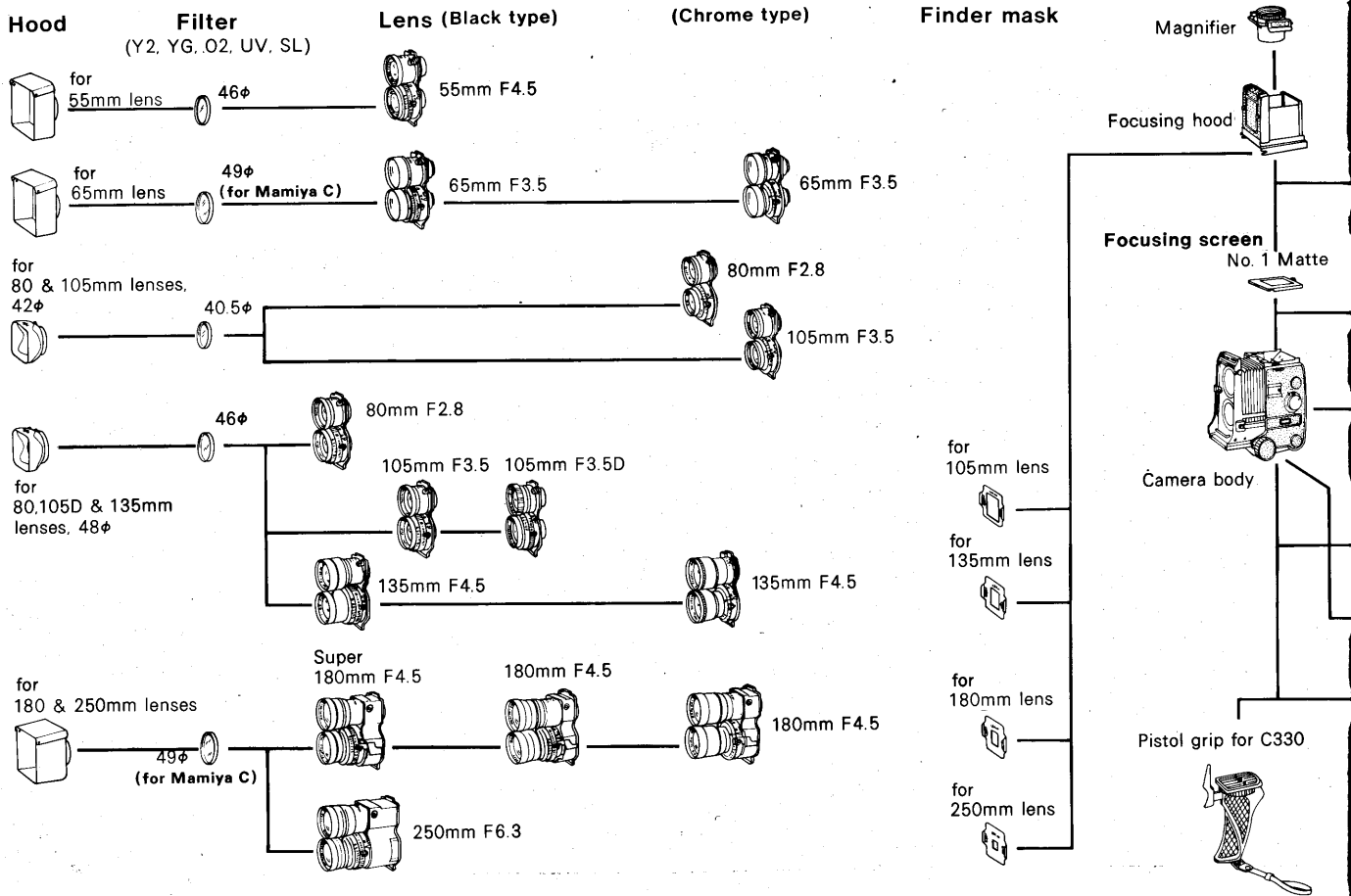

Magnifying hood



Porrofinder



CdS porrofinder



Prism finder



No. 2 Rangefinder spot 4



No. 3 Rangefinder spot 6



No. 4 Microprism



No. 5 Cross hair



No. 6 Checker



Back cover (standard)



Single exposure back



Cut film/plate holder model 2



Film sheath type J (for one-quarter size of 4 3/4 x 6 1/2 in. film)



Film sheath type D (for 2 1/2 x 3 1/2 in. 6.5 x 9cm cut film)



Tripod adapter type P



Quick-shoe



Focusing knob adapter



Grip holder for C330 and RB



Grip holder



Paramender Model 2



Paramender model 3 with pan head

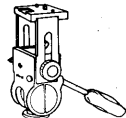

Flashgun Adapter

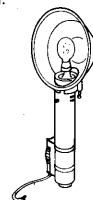

Flashgun

Strap



Case

Lens case

for 55mm Lens

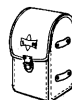

for 65mm lens



for 80mm lens

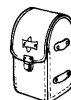

for 105mm lens



for 135mm lens



for 180mm lens



for 250mm lens



Camera leather case

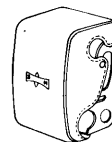

Soft leather case



Compartment case (for Mamiya C)

