

7909-0256Y1

# Instructions for Use

*3.4.5.05*

**GOSSEN**

# PROFISIX

## Contents

## Page

The PROFI SYSTEM	2
Before you start measuring	4
Set the film speed	4
Test zero position	4
Test the battery	5
Light measurement	6
Standard setting	6
Extended measurement	8
Modification of standard exposure	9
Extension factors	10
Exposure value modification	11
Modification of exposure times	12
Reading the scales	13
Extreme film sensitivities	14
Reflected – incident light measurement	15
Measuring circle of the PROFISIX	18
DIN/ASA values	20
Optimal exposure	21
Lighting – creativity	24
Measuring contrast	25
Zone system	26
Spectral sensitivity	27
Reciprocity effect	28
Specifications	32
The PROFISIX principle	34
Light intensity and luminance	35
The universal PROFI-SYSTEM with its attachments	37

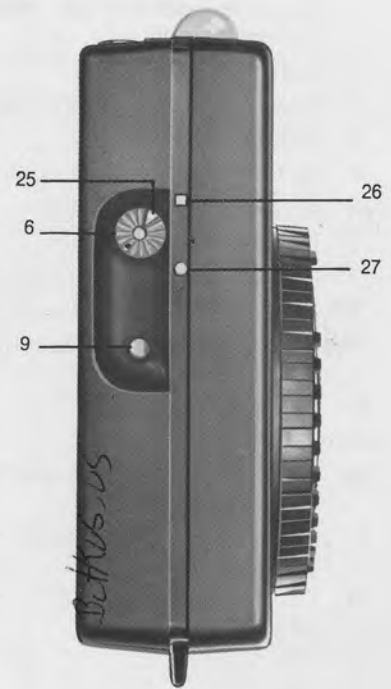

THE PROF. SYSTEM

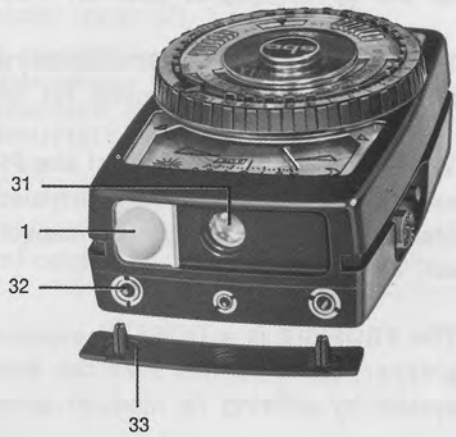

- |    |  |    |   |
|----|--|----|---|
| 1  | Spherical diffuser (for incident light measurement)  | 17 | Exposure Time Scale                                     |
| 2  | Indicator scale  | 18 | Aperture Scale (f-stops)                                |
| 3  | Zero scale adjustment line   | 19 | Cine Scale (frames per second)                          |
| 4  | Indicator needle   | 20 | Ribbed film speed setting disk                          |
| 5  | Rotation direction indicators  | 21 | Index for DIN/ASA setting                               |
| 6  | Measuring button (red)   | 22 | Exposure Value (EV) scale                               |
| 7* | Red triangles  | 23 | Setting ring for modified settings                      |
| 8* | Red arrow for flash readings  | 24 | Computer ring for setting indicator needle              |
| 9  | Button for battery test (green)  | 25 | White selector index for measurement duration           |
| 10 | White index line for extension factor setting  | 26 | Square setting mark for single measurement with storage |
| 11 | Extension factors  | 27 | Round setting mark for extended measurement cycle       |
| 12 | Eyelet for neckstrap   | 28 | Zero scale adjustment screw                             |
| 13 | EV (Exposure Value) modification scale (+ and -)   | 29 | Lux and Footcandle scale equivalents                    |
| 14 | Reading dot for cinematographers ( $1/50$ sec)   | 30 | Battery chamber   |
| 15 | White index line for EV modification setting   | 31 | measuring aperture                                      |
| 16 | Sliding black cover for red signal   | 32 | Outlets for connection of accessories                   |
|    |  | 33 | Protective cover for accessory outlets                  |
|    |  | 34 | Division for zone system                                |

\*) used only for measurements with PROFI-flash attachment (page 35)

## **The PROFI SYSTEM**

**The PROFISIX** is a top quality hand-held exposure meter, precise and reliable, with all the advantages of such an instrument.

**The PROFISIX** is a System Exposure Meter which, by means of various attachments, becomes a specialized meter for the most diverse applications of photography.

**The PROFISIX** is the heart of the PROFI SYSTEM. Through many years of practical experience and the most modern electronic technology the idea of a System Exposure Meter has ripened to a concept that offers greater measuring capabilities with still easier operation.

**The PROFISIX** is a GOSSEN exposure meter for the demanding professional photographer; yet it permits even the advanced amateur to devise his individualized own system by utilizing its modular accessories.

The silicon photo diode (silicon blue cell) of the PROFISIX achieves an instant measuring response — even at extremely low light levels. Its superior filtration results in a spectral sensitivity of outstanding character (page 27).

The accessories complement the PROFISIX for readings with smaller measuring angles, for spot-, flash-, and color temperature measurements, for use in the darkroom and in photomicrography, for footcandle measurements as well as densitometric readings. When accessories are attached to the PROFISIX, its electronic circuitry is automatically modified so that you can take scale readings without applying correction factors.

Please acquaint yourself with this fine instrument by reading this instruction booklet; it gives many valuable suggestions to assure you of getting consistently good results.

## Before you start measuring



### Set the Film Speed

Turn the film speed setting disk (20) by its ribs until the DIN/ASA index number of your film is lined up with the white triangle (21) above the DIN/ASA scale window. You will find a detailed DIN/ASA table on page 20.

Make sure the black cover (16) conceals the red signal; the white index line (15) must be at the red "0", and the opposite white index line (10) at "1" (Standard Setting). You can rotate the inner setting ring (23) by its raised cleats or by the black cover (16) to adjust the setting (see page 9).

### Test Zero Position

With the (switched off) meter in horizontal position, the indicator needle (4) should cover the short green line (3) as you look straight down. If necessary, adjust the indicator needle to the zero line by turning the zero adjustment screw (28) on the underside of the PROFISIX. The

PROFISIX is switched off if the measuring button (6) was not depressed and if the storage time (see page 7) has expired. (To be perfectly certain, you may also remove the batteries.)

It is sufficient to make this test at prolonged intervals.

### Test the Battery

The PROFISIX operates on a 9V battery; IEC 6 F 22. It is supplied with an Alkaline battery which is preferable because of its superior technical characteristics. You will find a listing of suitable batteries on page 29.

It is advisable to check the condition of the battery from time to time: After depressing the red measuring button (6), hold down the green battery test button (9). The indicator needle (4) should now come to rest in the green area marked "BATT". Otherwise, the battery must be replaced.

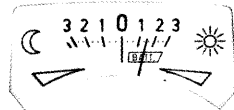

### Replace the Battery

To replace the battery, remove the cover of the battery chamber (30) on the underside of the PROFISIX by sliding it off in the direction of the arrows.

After inserting the fresh battery, make the test described above.

## Measurement

The two methods of measuring — reflected or incident light measurement — are described on pages 15 to 17. A hand held exposure meter like the PROFISIX is particularly well suited to the alternate application of either measuring method.

As the basic component of the PROFI-SYSTEM, furthermore, the PROFISIX provides the capability of programming for Extension Factors and Exposure Compensation Factors to give you direct read-outs without further calculations on your part (see page 8).

The normal half-minute measuring cycle of the PROFISIX can be overridden for extended measuring times with the red measuring button (6) (see page 8).

### Standard Setting

Measuring with the Standard Setting means that the red signal field is concealed by the black cover (16) and the white selector index (25) on the measuring button (6) is set at the square setting mark (26).



6

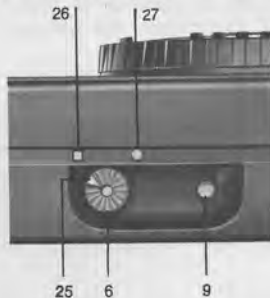

After the spherical diffuser (1) has been set for the desired measuring method, depress the measuring button (6). The PROFISIX measures as long as this button is held down. When you release the button (6), the value measured at that moment will be automatically stored in the electronic memory of your PROFISIX for half a minute.

You then rotate the computer ring (24) until the indicator needle (4) points exactly at the "0" (3) on the indicator scale (2). The direction signals (5) tell you in which direction the computer ring (24) must be rotated.

After you have set the needle at "0", your PROFISIX gives you complete exposure information in combinations of f-stops and exposure times (17 and 18), or (for motion picture cameras) f-stops for a specific operating speed in frames per second (18 and 19) (see also page 13).

At the end of the storage cycle the PROFISIX switches itself off automatically and the indicator needle (4) returns to the green zero line (3). Your measured reading remains set on the scales as long as you do not move the computer ring (24).

If you want to make a new measurement before the one-minute cycle is ended, simply depress the red measuring button (6); this clears the electronic memory and the new measurement is stored when you release the measuring button.

## Extended Measurement

You can override the electronic storage to make measurements which require more measuring time (for example: extensive contrast measurements). For extended measuring, depress the red measuring button (6) and lock it in place by turning it so that the white selector index (25) is set at the round setting mark (27). Your PROFISIX now indicates the consecutive values of various measurements without storage, and the meter does not switch off automatically. Naturally, this also puts a heavier load on the battery.

To end the extensive measuring mode, depress the measuring button (6) and turn it to the left so that its white index (25) is set at the square setting mark (26) again. The value measured at the moment of releasing the button will be stored for approximately half a minute, after which the PROFISIX switches itself off.

**Please don't forget — after completing extensive measurement — to turn the white index of the measuring button to the square setting mark (26) so that the PROFISIX switches itself off after a minute.**

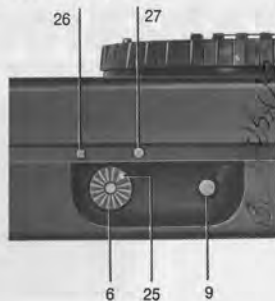

## Modification of Standard Exposure

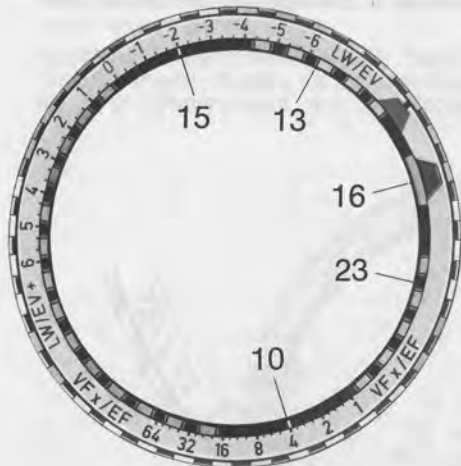

Specific modification of the standard exposure may be desirable or necessary for a number of different reasons, e.g. when using filters (filter factors or f-stop factors may be given), when using cameras with bellow extension, using extension rings, working with Macro lenses, or to compensate for reciprocity failure (see page 28) or when using the zone system (page 24).

You can set the applicable exposure value differences accurately on the outer scales (11) and (13): While holding the computer ring (24) rotate the inner setting ring (23) until one of the two white index lines (10) or (15) is set to the desired value. With such a setting the red signal under the cover (16) becomes visible to indicate, at a glance, that an extension factor or exposure value modification has been set on the scales.

## Extension Factors

The scale for extension factors (11) is logarithmic. Intermediate factors indicated by scale lines are listed in the illustration.

Example: You want to use a filter marked "4x". Set the white index line (10) of scale (11) to "4", as shown in the illustration on page 9. The filter factor will now be considered automatically in your measurements with the PROFISIX.



## Exposure Value Modification

You can set an exposure value modification with the white index line (15) on the green scale (13).

Example: If the filter is marked “-2EV” you set the white index line (15) of the green scale (13) to “-2”. This factor will now be considered automatically.



## Modification of Exposure Times

In the event that exposure time tolerances of your camera, or the sensitivity of your film (page 23) require shorter exposure, you can also set the applicable values on the green scale (13), by increasing the exposure value.

Example: You have determined that, for optimal results,  $\frac{2}{3}$  less exposure is required. Set the white index line (15) at "+ $\frac{2}{3}$ " (higher exposure value). This factor is then automatically considered when you read the exposure scales



## Reading the scales



'2, '4, '8 are fractions of seconds.

Un-marked numerals 1, 2, 4 are full seconds.

1<sup>m</sup>, 2<sup>m</sup>, 4<sup>m</sup> etc. are minutes.

1<sup>h</sup>, 2<sup>h</sup>, etc. are hours.

The un-numbered white dot between '30 and '60 is the reading point for cinematographers ( $1/50$  sec).



CINE frames per second  
(intermediate values)

**CINE f.p.s. and corresponding exposure times.**

**Note:** On some motion picture cameras, the exposure time at 18 f.p.s. is not  $1/36$  second.

**Please check instructions for your camera!**

## Extreme Film Sensitivities

When using exceptionally "fast" or "slow" films, the computer may, in extreme cases, show scale position as illustrated here. In these cases, exposure times are shown opposite small and large f-stops.

Here only the exposure times indicated in the upper half of the computer ring apply.



## Reflected Light Measurement – Incident Light Measurement

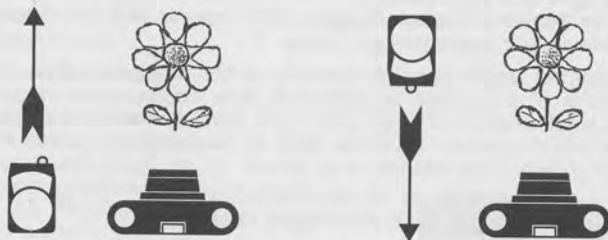

**Reflected Light Measurement.** Move the spherical diffuser (1) all the way to the right until it clicks into place. Point the PROFISIX toward the subject, as indicated by the arrow in the illustration. The measuring angle is  $30^{\circ}$ .

**Incident Light Measurement.** Move the spherical diffuser (1) so that it clicks into place centered over the round window. Point the PROFISIX from the subject toward the camera, as indicated by the arrow in the illustration. The measuring angle limitation is eliminated.

In **reflected light measurement** (from camera toward subject), the PROFISIX measures the light reflected by objects within a  $30^\circ$  angle (see also page 18 "Measuring circle of the PROFISIX"). The resultant reading depends on the intensity of the illumination and on the reflecting properties of the scene. Thus, under identical illumination, the indicator needle will be deflected less by dark objects than by bright ones. The PROFISIX adds the light and dark portions and indicates an average value. Therefore, if either dark or light areas predominate, better results will be obtained with the method of incident light measurement (page 17).

The small  $30^\circ$  measuring angle permits carefully aimed measurements. You can "sample" various parts of the scene to determine how contrasty or balanced the subject is in its overall brightness. For gray card measurements, too, the small measuring angle is advantageous. To make such a measurement, place the gray card in the area of greatest importance in a scene.

You can reduce the measuring angle of the PROFISIX to  $10^\circ$ ,  $5^\circ$  or  $1^\circ$  with the PROFI-spot, to  $15^\circ$  or  $7.5^\circ$  with the TELE (see pages 19 and 41).

In **incident light measurement** (from subject toward camera) the PROFISIX measures all the light falling on that part of the subject which faces the camera. The resulting measurement is primarily determined by the illumination while the reflecting properties of the scene can have only a minor influence on the measuring result. The method of incident light measurement is generally preferable, and you can prove with your PROFISIX that this method leads more assuredly to good exposures under difficult conditions – such as contrasty subjects – than reflected light measurement.

With inaccessible subjects, take the incident light measurement at a **substitute spot which receives the same illumination** as the subject. Instead of pointing the PROFISIX toward the camera, point it parallel to an imaginary line from subject to camera. This convenient method of incident light measurement at a substitute spot is also recommended for regular outdoor scenes. You merely do “about face” at the camera position with your PROFISIX and measure the light opposite the direction of the camera.

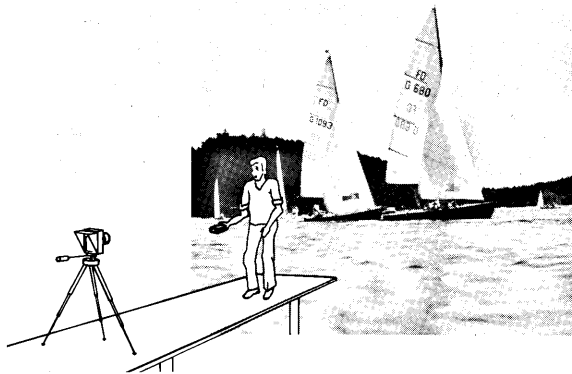

## Measuring Angle of the PROFISIX

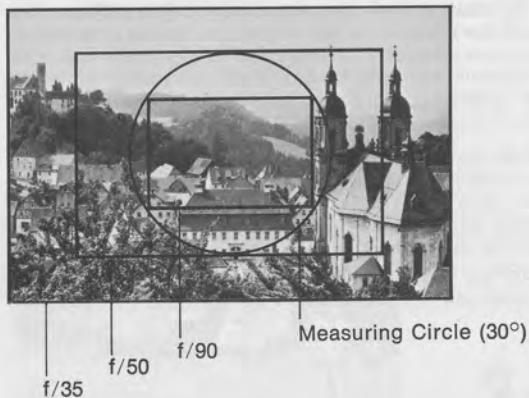

Size 24 x 36 mm

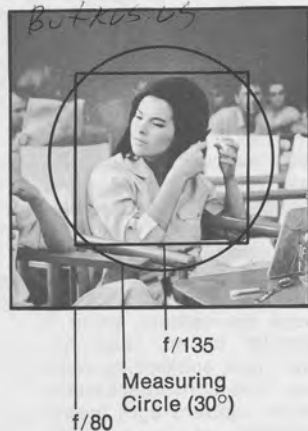

Size 6 x 6 cm

The acceptance angle of the PROFISIX can be reduced with the attachments PROFI-spot and TELE (page 41).

You can estimate the size of the measuring angle by comparison with the viewfinder or groundglass image. The illustrations show the relation for the sizes 24 x 36 mm and for 6 x 6 cm as well as 4.5 x 6 cm, with lenses of various focal lengths, when reflected light measurements are made from the camera position.

The measuring circle of the PROFISIX corresponds to the generally accepted 30° measuring angle. You can reduce this already small angle with the PROFI-spot attachment even further to 10°, 5° or 1° (page 41) or the TELE-attachment to 15° or 7,5° and, incidentally, adapt it to the angles of your tele lenses. For the size 24 x 36 mm, the three measuring angles of 10°, 5° and 1° of the PROFI-spot, for example, correspond to focal lengths of 150 mm, 300 mm and more than 1000 mm.

These small measuring angles also enable you to make **spot readings**; by measuring the lightest and darkest portions of the subject you can determine contrast range.

In **close-up measurements** the PROFISIX concentrates on the most important parts of a scene. The smaller angles make such measurements more convenient and more precise.

## DIN/ASA Values

DIN	ASA	DIN	ASA	DIN	ASA
0	<b>0,8</b>	18	<b>50</b>	36	<b>3200</b>
1	1,0	19	64	37	4000
2	1,2	20	80	38	5000
3	<b>1,6</b>	21	<b>100</b>	39	<b>6400</b>
4	2,0	22	125	40	8000
5	2,5	23	160	41	10000
6	<b>3,2</b>	24	<b>200</b>	42	<b>12500</b>
7	4,0	25	250	43	16000
8	5,0	26	320	44	20000
9	<b>6</b>	27	<b>400</b>	45	<b>25000</b>
10	8	28	500	46	32000
11	10	29	650	47	40000
12	<b>12</b>	30	<b>800</b>	48	<b>50000</b>
13	16	31	1000	49	64000
14	20	32	1250	50	80000
15	<b>25</b>	33	<b>1600</b>	51	<b>100000</b>
16	32	34	2000		
17	40	35	2500		

The DIN/ASA scales of the PROFISIX show only the values listed here in **bold type\***; intermediate ( $1/3$  step) values are indicated by short lines on the scales.

Doubling or halving an ASA value is the equivalent of one step, i.e. the same as changing the exposure value (light value) by 1, or changing the DIN number by 3.

\*) For space reasons, values starting with ASA 1600 are shown in "kilo"- (1000) ASA. Example: 1.6 k = 1,600 ASA.

## Optimal Exposure

Normally, optimal exposure requires that the brightest portions of a color transparency (color slide) and the darkest portions of a color- or black-and-white print, should still show adequate detail. Personal taste, artistic creativity and other considerations may, of course, change such basic rules. However, the following general recommendations may be noted:

In **reversal color** (transparency) film the lighter portions of a scene usually determine the exposure. Please keep this in mind and, preferable, use somewhat shorter rather than overexposure. Colors will be more brilliant and saturated.

For color- or black-and-white **negative Films**, however, the shadow portions must be given special consideration. Use longer rather than underexposure.

### Night Pictures

To preserve the night effect of darkness with little detail, you should actually use less exposure than the PROFISIX indicates so that the result does not look like a daylight scene. However, the "reciprocity effect" often produces the same results as shorter exposures, but there are no definite rules about it. To gain experience, start out with night exposures indicated by your PROFISIX.

The **reciprocity effect** is fully explained on page 28.

### Snow

In a snow-covered landscape, a reflected light measurement will almost always indicate too short an exposure; because of the snow's high reflectance, important parts of the scene (people, houses, or trees in the foreground) would be underexposed. Therefore, exposure modification of 1 to 1½ steps longer exposure is advisable.

It would be simpler to use the incident light measurement method because it indicates correct exposure directly. If you want to get special effects – for instance an emphasis on the subtle shadows in the snow – modify the reading to  $1/2$ –1 step shorter exposure.

Your PROFISIX makes such modifications easy for you (page 11).

Your PROFISIX enables you to measure any subject or scene accurately. Remember, however, that extreme contrasts may exceed the contrast range of your film.

### **The Influence of "Tolerances"**

The PROFISIX gives you exact exposure information. However, if your results are not perfectly satisfying, remember that all sorts of tolerances may influence the outcome of your photographs. For example

- the "true" sensitivity of your film may differ somewhat from the one indicated on the package;

- the "true" shutter speeds of your camera may differ somewhat from the values shown on the shutter speed dial;

- the "true" apertures of the lens may differ somewhat from those engraved on the f-stop scale of the lens;

- the film processing may not always be identical.

We have already mentioned the purely subjective considerations and matters of taste which enter into any assessment of picture quality.

But, you can adapt your PROFISIX to the characteristics of your camera, your favorite film, your type of processing, your projector!

Here is how to do it: Use a reversal color (slide) film; select several "normal" scenes; take careful reflected and incident light measurements. Then make two series of 5 exposures of each of the selected scenes — one series based on the reflected light, the other on the incident light reading. In addition to an exposure made at the exposure indicated by your PROFISIX, make one exposure each at a full step and one-half step more and less exposure than indicated. Light conditions during the test series should remain constant. Make complete notes of the readings and any special conditions. Finally, when you have your finished transparencies, select the ones which, in your judgement, are "perfect" and check them against your notes on exposure. Should you find that you prefer transparencies made with altered exposures, you can readily adapt your PROFISIX to the appropriate setting by adjusting the ring (23) for the modified setting (see page 11).



## **Lighting – Creativity**

Light creates photographs. While you can hardly influence lighting conditions outdoors, you can achieve outstanding pictures indoors by your own creative use of lighting. Remember, however, that film has only a limited contrast range. For black-and-white film, the contrast ratio should not exceed 5 or 6 steps; for color films, 3 steps at the most. Color films for TV transmission or exposures on sheet film for reproduction in the graphic arts require even narrower limits – preferably not more than 2 steps. Take an incident light measurement of the key light, and then of the – weaker – general light. In this case you only have to watch the needle deflection (4) on the scale (2).

If you want to achieve soft lighting with little or no contrast – as in high key subjects – arrange your lights so that you get identical meter readings at different areas of the subject and background (if any). All measurements should be taken in the incident light mode.

## Measuring Contrast

### Scene brightness range

The PROFISIX is ideally suited for this type of measurement because of its null meter design and a scale range over six f/stops which are subdivided in 1/3 f-stops. Contrasts can be measured quickly and without any problem at all. Without further adjustment of the calculator you just watch the needle movement when taking readings from highlight to shadow areas and read the variance of these areas in f/stops on the scale. Furthermore the ratio of different brightnesses when compared with each other or when compared with a chosen reference point will be indicated directly. Also the contrasts in lighting being of particular importance for the creative composition of the picture can easily be determined.

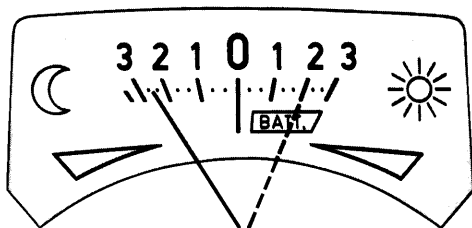

## Zone System

There are times when the lighting range cannot be brought within the acceptance limits of the film and paper contrast ranges. When these situations arise, the zone system can be used. In doing so, detail can be recorded which would otherwise be lost. A complete discussion of this technique is far beyond this instruction booklet.

The PROFISIX is well suited for using the zone system because of its measuring principle. For this purpose, the computer ring (24) of the PROFISIX shows the figures I to IX (34). Based on the important parts of your subject ~~zone V~~ when the central diode is on, the range from high-light to shadows in the scene are measured. Their variance from the middle zone determines the amount of exposure correction and processing modification that is needed.

Depending on the nature of the contrast range and also in case of extreme contrast the standard exposure is not to be applied, but a modified exposure must be used according to the contrast range (sometimes 1 to 2 stops) in order to receive proper exposure for the most important highlight and shadow parts. This may entail that some detail in the less important areas will be lost.

5 \_\_\_\_\_ (zone V when the needle is on zero) \_\_\_\_\_

## Spectral Sensitivity of the PROFISIX

The PROFISIX utilizes special filters in front of the light sensor to provide a relative spectral sensitivity that closely matches the spectral sensitivity distribution of films, for optimum compatibility.

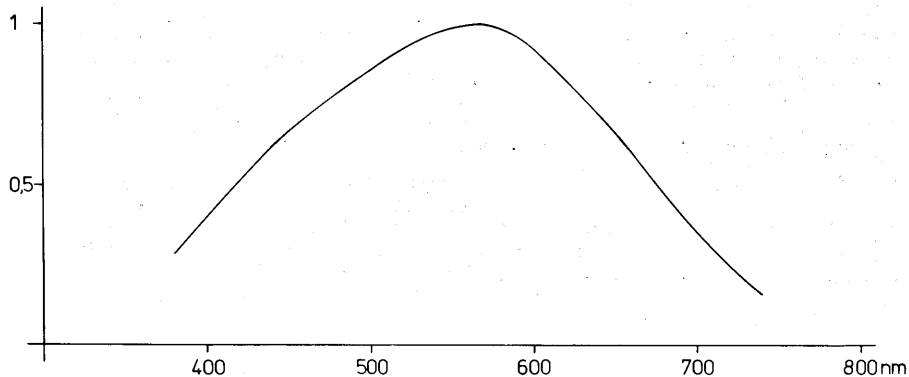

Average relative spectral sensibility of silicon blue cells  
according to manufacturers' indications

## **Reciprocity Effect**

Photography under poor light conditions may require exceptionally long exposure times. In such circumstances, films of all types and makes are subject to a phenomenon called "reciprocity effect": Measured exposure times must be increased to avoid underexposure. Films of various types and makes react differently to such longer exposures; therefore the reciprocity effect was not considered in the computer scales of the PROFISIX. On the other hand, once you know the necessary exposure modification factor for a given film type, you can easily set it on your PROFISIX when you encounter extra long exposure times (see page 11).

Some color films come provided with special data sheets containing instructions for very long exposures. Some information of that type is being reprinted on the following pages. However, most recent data are to be obtained, in any case, from the film manufacturers.

The reciprocity effect may also cause shifts in the color balance which can be compensated by using correction filters.

With the permission of the makers, we are reprinting their indications concerning the reciprocity effect in some of their film types.

For Agfacolor Professional Film 80 S and Agfacolor Negative Film CNS 2 and Pocket Special:

Increasing the exposure time  
for long exposures

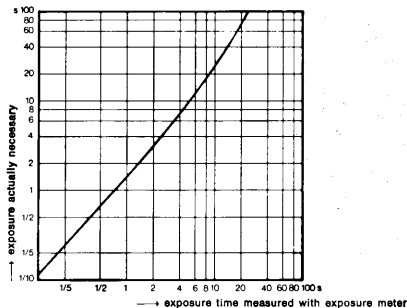

Neutral adjustment for  $1/125$  second. No visible deviations in the adjustment from  $1/1000$  second to full seconds

Recommendations for correcting the reciprocity effect

Film type	Exposure time measured (seconds)					
	1/1000	1/125	1/15	1	10	100
Kodacolor II *	—	—	—	1/2	1 1/2	2
	—	—	—	—	10 Y	10 Y
Kodak Vericolor II Prof. Type S	—	—	—	not recommended		
	—	—	—			
Kodak Vericolor II Prof. Type L	not recommended		See Film data sheet with exposure indications from 1/50 sec. to 60 seconds exposure time			
Kodachrome 25 Daylight	—	—	—	1	1 1/2	2 1/2
	05 C	—	—	05 R	10 R	10 M
Kodachrome 64 Daylight	—	—	—	1 1/3	1 2/3	not recommended
	05 C	—	—	05 R	10 R	
Kodachrome II Type A (artificial light)	—	—	1/3	2/3	1 1/3	not recommended
	—	—	—	05 Y	10 Y	

Upper line: correcting exposure by opening by . . . f/stops  
 Lower line: color correction = CC Filter

Film type	Exposure times measured (seconds)					
	1/1000	1/125	1/15	1	10	100
Kodak Ektachrome 50 Type B (artificial light)	—	—	—	—	1/2	1 1/2
	10 C	10 C	—	—	—	—
Kodak Ektachrome 64	—	—	—	1/2	1 1/3	not recommended
	—	—	—	—	10 B	
Kodak Ektachrome 200 (daylight)	1/2	—	—	1/2	not recommended	
	—	—	—	10 R		
Kodak Ektachrome 160 (artificial light)	—	—	—	1/2	1	not recommended
	—	—	—	10 R	15 R	

The above indications for the various film types are average values. They apply only when the film is exposed to the light the film is laid out for and processed in the chemicals stipulated for that type. Please consider these indications to be recommendations only, they are subject to changes due to normal manufacturing variations and film storage conditions after the film leaves the factory.

\*) at 1/25 000 s open 1/2 stop and CC 10 B filter  
at 1/50 000 s open 1 stop and CC 20 B filter

The f-stop values indicated for correction include the extension factors due to using the recommended filters.

## Specifications

Measuring range	for reflected light — 0.002 fL to 4,000 fL 0.007 cd/m <sup>2</sup> to 14,000 cd/m <sup>2</sup> for incident light — 0.016 fc to 32,000 fc 0.17 lx to 350,000 lx
Exposure times	1/4000 second to 8 hours
Lens apertures	f/0.7 to f/128
Cine speeds	4.5 to 144 frames per second
Film sensitivities	0 DIN to 51 DIN; ASA 0.8 to ASA 100,000
Light sensor	lag-free silicon photo diode (silicon blue cell = sbc)
Measuring methods	reflected and incident light measurement
Measuring angles	for reflected light 30° for incident light 180°
Measurement hold (storage)	approx. 30 seconds; thereafter automatic switch-off

Battery type

Battery check

Mechanical zero adjustment

Temperature compensated

Stabilized current

Battery 9 V IEC 6 F 22 or IEC 6 LF 22 \*)

\*) This international norm codes correspond to the following batteries for example:

Mallory MN 1606 (Alkali)

Mallory M 1604

Daimon No. 332

Daimon No. 333

Varta Super 438

Novel 006 P (T)

Novel 006

Maxell S-006 P (G)

or to the rechargeable  
battery Varta 4022 IEC 6 LF 22 E BI  
9 V Alkaline.

## The PROFISIX principle

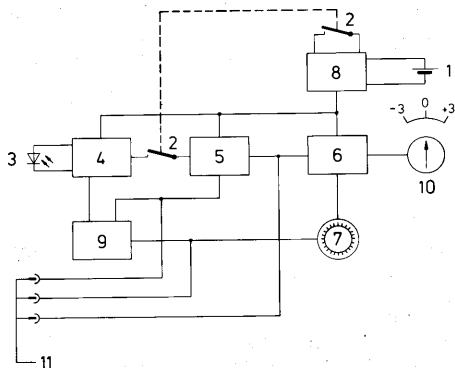

- 1 Battery
- 2 On-off switch
- 3 Silicon photo diode (sbc)
- 4 Output current measurement and logarithmic conversion
- 5 Sample-and-hold circuit (storage)
- 6 Differential amplifier
- 7 Computer ring
- 8 Automatic switch-off
- 9 Reference voltage
- 10 Measuring movement
- 11 Outlets for attachments

The PROFISIX employs a silicon photo diode (sbc = silicon blue cell) as its light sensitive element. Its output current is measured logarithmically in block (4). (The more light falls on the diode (3), the greater is the output current.) The resulting measurement is stored in block (5) for approximately half a minute, after which the automatic switch-off (8) erases it. From block (9) a reference voltage reaches the

differential amplifier (6) via a precision potentiometer which is connected to the computer ring (7). The measured value from block (5) is also available at the differential amplifier. The difference between the two values is transferred to the measuring movement (10) and causes a needle deflection on the meter face. By turning the computer ring (7) the indicator needle can be exactly moved to "0".

## **Light Intensity and Luminance**

### **Light Intensity in Lux and Footcandles**

Light intensities can be measured only by means of a flat interception screen, while exposure meters are primarily designed to achieve collection of the photographically effective illumination. Photographic subjects are usually three-dimensional, and they receive illumination from many different directions (sun, sky, reflections from buildings, trees, ground etc.). Therefore, for incident light measurement the spherical diffuser is slid in front of the cell window.

Nevertheless exposure meters can be useful for the determination of approximate light intensities. The table (29) on the back of the PROFISIX shows the approximate value of light intensity in Lux (lx) or Footcandles (fc) corresponding to the exposure values (Light values) (22) obtained by the incident light measuring method, with the film speed set at 18 DIN/ASA 50.

For more accurate light intensity measurements with the PROFISIX, use the studio attachment PROFI-lux (page 38).

## Luminance In Candela per Square Meter or Footlamberts

Reflected light measurement indicates the light reflected by the subject, i.e. luminances. The measured value indicates how much light the area ( $m^2$ ) radiates. The unit value is "candela per square meter" ( $cd/m^2$ ). (Formerly the unit value "apostilb" (asb) was used).

For comparison purposes between the two measuring methods: The measured values for reflected light measurement (gray card 17 to 18%) expressed in  $cd/m^2$ , are approximately  $1/24$  the Lux values obtained in incident light measurement. The values are also given in Footcandles (fc) and Footlamberts (fL).

### Examples:

Exposure value (EV) at 18 DIN	- 3	- 2	- 1
lx (incident light measurement)	0.7	1.4	2.8
fc (incident light measurement)	0.064	0.125	0.25
$cd/m^2$ (reflected light measurement)	0.028	0.055	0.11
fL (reflected light measurement)	0.08	0.016	0.032

Scientifically accurate measurements can be made only with footcandle (lux) meters such as the PANLUX electronic or MAVOLUX electronic. For luminance measurements both instruments are complemented with luminance attachments.

*www.btk.us*

## The universal PROFI-SYSTEM

By means of its attachments, the capabilities of the PROFISIX can be expanded for use in the most diverse special fields of photography.

Yet, with all its versatility, the PROFI-SYSTEM is easy to use: By plugging in the attachments, the electronic circuitry of the PROFISIX is automatically adjusted to compensate for any necessary correction values of the attachments.

On the following pages you will find:

PROFI-lux	for measuring illumination or luminance
PROFI-select	
TTL	for measuring in the film plane
PROFI-flash	for flash exposure measurements
PROFI-color	for measuring color temperature and determining conversion filters
PROFI-flex	for measurements on the groundglass, on small objects, at otherwise inaccessible areas
PROFI-micro	for exposure measurements in photomicrography
PROFI-spot	for reduction of the measuring angle to $10^\circ$ , $5^\circ$ or $1^\circ$
TELE	for variable angles of $15^\circ$ and $7,5^\circ$
LAB	for measurements in the darkroom
REPRO	for exposure determination in copy work

## PROFI-lux



Studio attachment with 360° swivel head; for incident light measurement (sphere) and for measuring light intensities in lux or footcandles (flat diffusing disk).

## PROFI-select TTL



For measuring as well as continuous light as flash in the film plane of view cameras.

Each accessory is supplied with complete instructions for its specific applications.

## PROFI-flash



For measuring the flash of all types of electronic flash units.

## PROFI-color



By means of this attachment, the color temperature of light can be measured and, at the same time, the necessary conversion filter determined.

Each accessory is supplied with complete instructions for its specific applications.

## PROFI-flex

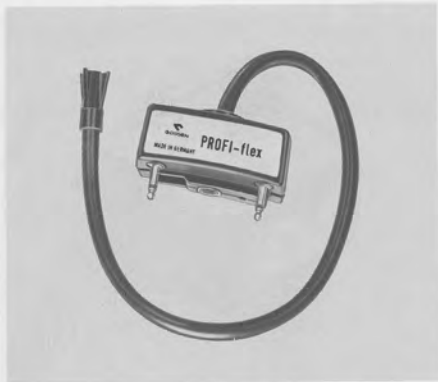

Attachment with fibre optics probe for exposure measurements on the ground-glass, on small objects, at otherwise inaccessible locations.

## PROFI-micro



For photomicrography measurements on the microscope.

Each accessory is supplied with complete instructions for its specific applications.

## PROFI-spot

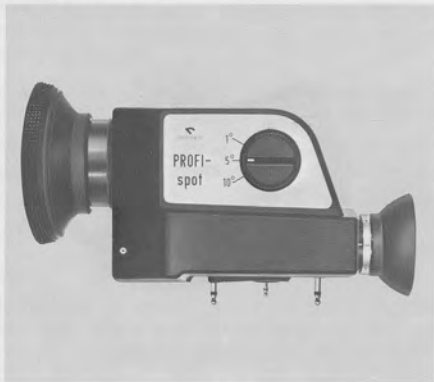

This attachment converts the PROFISIX into a spot meter with measuring angles of 1°, 5° and 10°.

## TELE



With the attachment TELE the PROFISIX takes readings of 15° and 7,5° measuring angles.

Each accessory is supplied with complete instructions for its specific applications.

LAB



For measuring contrast range and exposure in enlarging.

REPRO



For determination of exposures for reproduction (copy) work.

Each accessory is supplied with complete instructions for its specific applications.

## Using LUNASIX 3 Attachments

Your PROFISIX is designed also to accept attachments made for the LUNASIX 3. Naturally, automatic compensation for any correction values (as provided with the PROFISIX attachments) is not possible. Furthermore, operation is, in some instances, more involved.

If you use LUNASIX 3 attachments with your PROFISIX, you operate basically as you would with the LUNASIX 3, but the following should be noted:

Wherever scale values are given in the instruction folders for LUNASIX 3 attachments, corresponding exposure values (LW/EV) can be used and set.

Example: PROFISIX exposure value (LW/EV) equals LUNASIX 3 scale "-6"

In the instructions for the LUNASIX 3 LAB attachment, a scale value of "5" is indicated. On the PROFISIX this corresponds to an exposure value (LW/EV) of "-1".

If the **red** or **green** index of the LUNASIX 3 is mentioned, this can be considered with the PROFISIX by moving the EV modification scale (13) for the **red** index to "(+) 1, and for the **green** index to "(+) 3".

Example: You are using the TELE attachment of the LUNASIX 3 on your PROFISIX, set for the 7.5° measuring angle; you would have to set the scale value on the LUNASIX 3 to the **green** index. To consider the correction value on the PROFISIX, set the **white** index (15) at "(+) 3" on the EV modification scale (13).

If repair or adjustment should ever become necessary, send your PROFISIX, carefully packed, to:

GOSSEN GMBH  
Servicestelle B  
Nägelsbachstrasse 25  
D-8520 Erlangen

or to the GOSSEN agency in your own country.

To expedite handling please send your PROFISIX **only** — **without case and neck strap or other accessories.**