



CHINON

CE-4

**Compact 35mm
Electronic
SLR Camera**



INSTRUCTION MANUAL



ENGLISH

CONTENTS:

NOMENCLATURE.....	2		
SPECIFICATIONS.....	4	CONVENIENT FEATURES OF	
		CHINON CE-4	
YOUR CHINON CE-4		Interchangeable lens system	17
Basic procedure of using		Depth of field preview.....	19
Chinon CE-4	6	Built-in self-timer	21
Installing batteries	7	Manual exposure	22
Battery test.....	8	Multiple exposure	24
Film loading	9	Exposure memory	25
Frame counter.....	10	Exposure compensation.....	26
Film advancement.....	11	Chinon dedicated flash system ..	27
ASA setting.....	11	Power winder	30
Focusing.....	12	Infrared photography	33
Automatic exposure	13		
Shutter release and		CAMERA CARE	33
release lock.....	15		
Unloading exposed film	16	ACCESSORIES	34

CHINON
CE-4
Compact
35mm
Electronic
SLR Camera



NOMENCLATURE

(Please refer to figures A & B in accompanying illustrated guide.)

1. Film rewind knob and back opening knob
2. Film speed dial (ASA) Exposure compensation dial
3. ASA dial lock button
4. Accessory shoe (Hot shoe)
5. Shutter speed dial
6. Shutter release button
7. Film advance lever
8. Multiple exposure lever
9. Frame counter
10. Shoulder strap eyelet
11. Depth of field lever
12. Self-timer dial with LED
13. Lens lock release lever
14. Focusing ring
15. Depth of field scale
16. Aperture ring

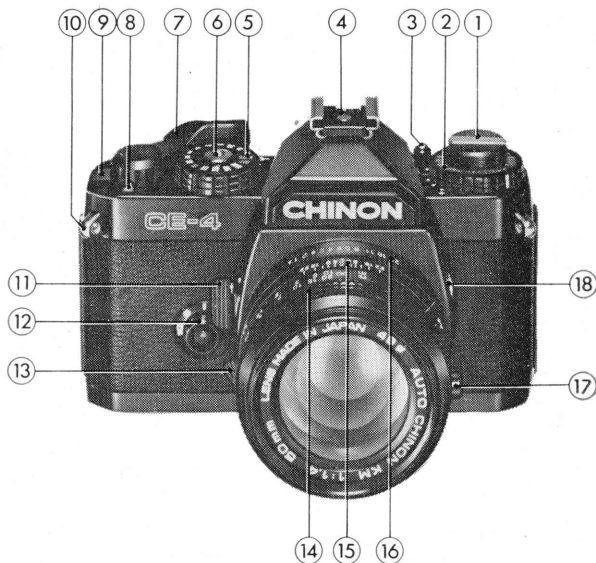

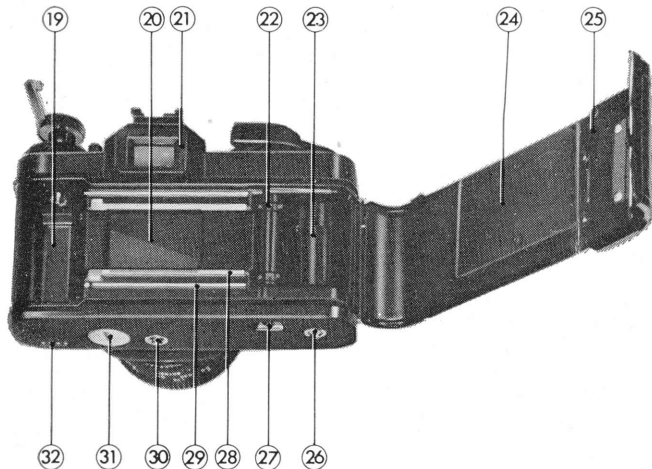

- 17. Exposure memory button
- 18. X sync socket
- 19. Film chamber
- 20. Metal focal plane shutter
- 21. Viewfinder eyepiece
- 22. Sprocket teeth
- 23. Take-up spool
- 24. Film pressure plate
- 25. Camera back
- 26. Power winder coupler
- 27. Rewind button
- 28. Film rail
- 29. Film guide rail
- 30. Tripod socket
- 31. Battery chamber cover
- 32. Power winder electrical contacts



This manual is for reference and historical purposes, all rights reserved.

This page is copyright© by M. Butkus, NJ.

This page may not be sold or distributed without the expressed permission of the producer

I have no connection with any camera company

On-line camera manual library

This is the full text and images from the manual. This may take 3 full minutes for the PDF file to download.

If you find this manual useful, how about a donation of \$3 to: M. Butkus, 29 Lake Ave., High Bridge, NJ 08829-1701 and send your e-mail address so I can thank you. Most other places would charge you \$7.50 for a electronic copy or \$18.00 for a hard to read Xerox copy.

This will allow me to continue to buy new manuals and pay their shipping costs.

It'll make you feel better, won't it?

**If you use Pay Pal or wish to use your credit card,
click on the secure site on my main page.**

Donate: www.PayPal.me/butkus

venmo: @mike-butkus-camera Ph. 2083

SPECIFICATIONS

SPECIFICATIONS OF CHINON CE-4

Type: 35mm automatic SLR (Single Lens Reflex) compact camera with aperture priority exposure system (AE).

Picture Format: 24 X 36mm

Film Loading: Easy film loading by multi-slot take up spool.

Lens Mount: Chinon Bayonet Mount.

Standard Lenses: Chinon 50mm F/1.4, 50mm F/1.7, 45mm F/2.8 (All stop down to F/22).

Mirror: Large Quick return, shockless system.

Shutter: Seiko MFC electromagnetic metal focal plane shutter with downward vertical path; stepless speeds from 8 to 1/1000 sec. on automatic; 13 speeds from 4 to 1/1000 sec. on manual; "B". Both automatic and manual speeds electronically controlled.

Shutter Release: Two stage electromagnetic type with safety lock and provision for cable release.

Viewfinder: Fixed eye-level pentaprism, central split image with microprism collar and ground glass, 16 LED's indicate shutter speeds and over/under exposure. Over exposure LED blinks and under exposure LED will glow when exposure is -2EV and will flash at -2EV or lower.

Viewfinder Magnification: 0.87 X with 50mm lens set at infinity.

Viewfinder Visibility: 92%.

Depth of Field Preview: By depressing depth of field lever.

Exposure Meter: TTL, Center weighted full aperture system employing two silicon blue photo cells located on each side of viewfinder. Brightness of exposure LED's vary depending upon brightness of viewfinder.

Exposure Preview: By depressing shutter release half way metering system is activated.

Manual Exposure System: Complete manual override capability, match LED system.

Memory Lock: Built-in exposure memory lock system.

Exposure Compensation: Built-in $\pm 1EV$ in one third stop increments.

Exposure Range: EV-2(F/1.4 @ 8 sec.) to EV+19(F/22 @ 1/1000) ASA 100 50mm F/1.4 lens.

ASA Range: 25-3200 (DIN 15-36) with safety lock.

Film Advance: Single stroke in an arc of 130° with 25° stand off, motorized film advance with CHINON POWER WINDER (PW-530).

Multiple Exposure: Built-in switch which disengages film advance and frame counter. Automatically resets to normal position after each film advancement. UNLIMITED.

Film Counter: Automatically indicates number of exposures and resets to "S" when camera back is opened. Does not advance during multiple exposure.

Self-Timer: Electronically controlled at 5 or 10 seconds with flashing red LED indicator. Two seconds before exposure flashing frequency of red LED increases. Self-timer can be cancelled even after system has been activated.

Film Rewind: By depressing the rewind button and cranking the rewind lever. Rewind button automatically resets when the film advance lever is turned.

Accessory Shoe: Hot shoe type with X sync. and contact for Chinon dedicated flash.

Synchronization: "X" strobe sync. at 1/60 sec.

Flash System: Chinon dedicated flash or most conventional flashes.

Power Source: Three 1.5V Alkaline batteries (LR44, A76) or three 1.5V silver oxide batteries (SR44, S76, G-13).

Battery Test: Built-in with LED indicator.

Body Finish: Black.

Accessories: Chinon Power Winder (PW-530), Deluxe carrying case, Chinon Super Multi-coated lenses, Power Winder remote control, angle finders and many more.

Body Dimensions: 135.5 X 85 X 50.5mm
5.33 (W) X 3.34 (H) X 1.99 (D)".

Body Weight: 485 grams (17.10 oz.).

Basic Procedure



THE BATTERIES

CE-4

BATTERY INSTALLATION

Installing Batteries

Using a coin, unlock the battery chamber cover by turning it counter-clockwise. Place three 1.5V Alkaline batteries (LR44, A76) or three 1.5V silver oxide batteries (SR44, S76, G-13) in the battery chamber with the negative (–) side facing downwards (Fig. 1). Carefully insert the batteries into the camera body. Replace and tighten the cover securely by turning it clockwise (Fig. 2).

NOTE: CLEAN THE BATTERIES WITH A DRY CLOTH OR PAPER BEFORE INSERTING AND THEREAFTER AT REGULAR INTERVALS. MAKE SURE THAT THE BATTERIES ARE INSERTED CORRECTLY, i.e., CHECK POLARITY. THE SHUTTER WILL OPERATE ONLY WHEN BATTERIES ARE CORRECTLY INSTALLED AND NOT EXHAUSTED.



TESTING THE BATTERIES

BATTERY TESTING

Testing the Batteries

Set the shutter speed selector to "AUTO" (Fig. 3), and while looking at the shutter speed indicator scale in the viewfinder, slightly depress the shutter release button. If the batteries are in good condition (battery potential is high enough), at least one of the indicator LEDs will light up. If a LED fails to illuminate, the batteries are too weak and need to be replaced, they are incorrectly inserted, or the shutter speed selector is set to "OFF" or "B".

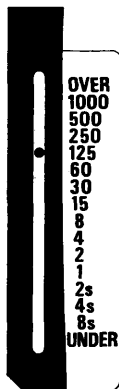

LOADING THE CAMERA

CE-4

FILM LOADING

Your Chinon CE-4 can be used with any kind of 35mm film.

Film Loading

Pull out the film rewind knob until the camera back pops open (Fig. 4). Then drop a film cartridge into the film chamber with its protruding end facing the bottom of the camera (Fig. 5). Push in the film rewind knob and slightly turn the knob in either direction until it catches the film cartridge spool. Insert the trimmed end of the film into a slot of the multi-slotted take-up spool. Turn the shutter speed selector to any setting except "AUTO" or "OFF" and advance the film while holding the film lightly down on to the transport sprockets.

Release the shutter if necessary and advance the film until the sprockets engage with the upper and lower perforations of the film (Fig. 6). Then close the camera back firmly until it locks with a click.

Now turn the film rewind knob gently until all the slack is taken up and the rewind knob stops. Do not force or further rewind the film. Advance the film and release the shutter three times (Fig. 7). **The rewind knob should rotate counterclockwise as the film is advanced** and the "1" marking should appear in the frame



LOADING THE CAMERA (Cont.) / FRAME COUNTER

counter window (Fig. 8).

Turn the shutter speed selector to the "AUTO" position (Fig. 9). A convenient memo holder is provided on the back of your camera. Whenever you load new film, just cut off the top of the film box and put it in the memo holder as a reminder.

Frame Counter

Your Chinon CE-4 is equipped with a frame counter which displays the number of exposures made and resets automatically upon opening the camera back. At the very beginning the counter shows "S" indicating the start of the picture taking process. When a film is loaded according to the procedure previously described, the counter displays "1" indicating that the camera is ready for the first exposure. Every time the film advance lever is turned the counter will proceed one stop forward. The numbers 24 and 36 are colored in orange to warn the end of commonly available films (Fig. 10).

FILM ADVANCE / ASA SETTING**GE-4****Film Advancement**

When the film end is reached the film advance lever may stop before the lever is fully turned. Do not force the lever. Stop winding at once and rewind the film. Refer to "Unloading Exposed Film."

ASA	DIN	ASA	DIN
25	— 15	400	— 27
50	— 18	800	— 30
100	— 21	1600	— 33
200	— 24	3200	— 36

ASA Setting

The ASA dial located on top of the camera is coupled directly to the internal exposure control circuitry and the correct exposure factor for the film is automatically set by aligning the ASA number of the film you are using with the index mark on the camera body (Fig. 11). The ASA number of the film is printed on the film box or in the instruction sheet packed with the film. Turn the ASA dial and align the appropriate ASA number with the green index mark. Be sure to check the ASA number whenever you put new film into the camera.



FOCUSING

Your Chinon CE-4 has three built-in focusing aids.

At the center of the viewfinder is the split image with microprism collar which is then surrounded by ground glass. When the camera is in focus, the image on these focusing aids becomes sharpest. While observing the subject through the viewfinder, turn the lens focus ring until the upper and lower split images match up to form a uniform image (Fig. 12). This split image focusing is particularly helpful when the subject is dominated by vertical lines. The microprism is also very helpful. When it is out of focus, the image on the microprism will be composed of a collection of asterisks (Fig. 13). These sparkling

asterisks will disappear when the focus is properly set. You can double check the focus setting by the image on the ground glass.

You can also focus indirectly. Actually measure or estimate the distance to the subject and set the lens focus ring to the appropriate setting (Fig. 14).

AUTOMATIC EXPOSURE

CE-4

Automatic Exposure

Your Chinon CE-4 features TTL, center weighted full aperture light measuring automatic exposure control. As long as the shutter speed selector is set to "AUTO" you don't have to worry about the exposure factor (Fig. 15). The sensitive and accurate internal circuitry will compute the correct exposure for the photographic condition and control the shutter speeds steplessly from an 8 sec. time exposure to a fast 1/1000 sec.

When the shutter release button is depressed half way, the exposure control circuit is energized and will be in the monitoring stage (Fig. 16). You can see the computerized shutter

speed displayed in the viewfinder by a red LED (Fig. 17). If the lens F stop or the aperture size is too large for the lighting condition, the over exposure indicator at the top of the scale will flash (Fig. 18). When this happens, stop down the lens diaphragm by turning the lens F stop ring or use a film with a lower ASA number. Another alternative is to use a ND (neutral density) filter in front of the lens. They are available as accessories from your local dealer. If the displayed speed is 1/30 or slower, use of a tripod is recommended. Or you can increase the shutter speed by opening the lens diaphragm. Use of a flash unit is also suggested. (Refer to "Chinon Dedicated Flash System").



AUTOMATIC EXPOSURE (Cont.) / F-STOP

the computed shutter speed is even longer than 8 sec. (semi-darkness condition), the under exposure indicator at the bottom of the scale will light up and flash when the available light is less than -2EV (Fig. 19).

F Stop Selection:

The following may be used as a guide to determine the lens F stop when you are using the camera in the automatic mode.

Sunny day outside F/8 -F/11
Cloudy day outside F/4 -F/5.6
Inside (without flash) . . . F/1.4 -F/2.8

SHUTTER RELEASE / RELEASE LOCK

CE-4

Shutter Release and Release Lock

Your Chinon CE-4 features a two stage electromagnetic shutter release with safety lock. When the shutter release button is depressed half way, the electronic circuit starts functioning. When the button is fully depressed, it will trigger the shutter. Always hold the camera steady and gently depress the shutter release button to make an exposure.

The position marked "OFF" on the shutter speed selector is the shutter release safety lock position. When this is aligned with the index mark, the batteries are disconnected from the circuit and exposure cannot be made (Fig. 20). This position is also used when the camera is not to be used for a long time.



UNLOADING THE CAMERA

Unloading Exposed Film

When the film in the camera is fully exposed, the film advance lever will stop. Do not attempt to force the lever any further, but rewind the film and replace with a new one.

Push in the rewind lock release button at the bottom of the camera (Fig. 21). Unfold the rewind crank of the rewind knob (Fig. 22). Turn the rewind crank clockwise. You will feel friction as the film is rewound. Suddenly, when the film is rewound completely, the friction decreases and the rewind crank will turn with ease. Then pull out the rewind knob to open the camera back (Fig. 23).

When the camera back is opened, the frame counter will automatically re-

set to "S". The rewind lock release button on the bottom of the camera will pop out upon the next advancement of the film advance lever.

Your exposed film should be processed without delay.

CONVENIENT FEATURES / CHANGING THE LENS

CE-4

CONVENIENT FEATURES OF YOUR CHINON CE-4

Interchangeable Lenses

Your Chinon CE-4 is equipped with a Chinon bayonet mount which accepts all interchangeable lenses with the bayonet mount. To remove the lens from the camera body, depress and hold the lens lock release lever on the camera body (Fig. 24), turn the lens counterclockwise as far as it will go, and lift it up from the body (Fig. 25).

NOTE: DO NOT REMOVE OR REPLACE THE LENS WHILE THE CAMERA IS FUNCTIONING.



CHANGING THE LENS (Cont.)

To attach the lens, match the red dot on the camera body with the red dot on the lens (Fig. 26). Then insert the

lens into the camera body and turn it clockwise until the lens locks with a click.

28mm

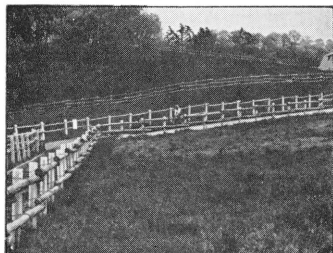
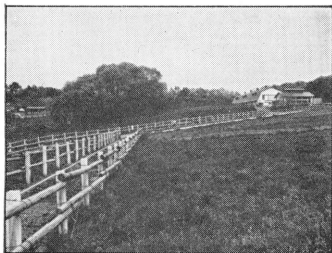

50mm

135mm

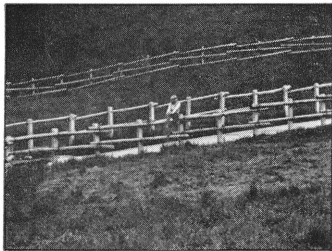

300mm

DEPTH OF FIELD

Depth of Field

Depth of field designates the nearest and furthest limits of the area that will be sharp in the picture in front of and beyond the subject. Depth of field is controlled by the f/stop. The larger the lens opening (f/stop), the shallower is the depth of field. The smaller the lens opening, the greater the depth of field will become (Fig. 27 and 28).

Visible Check in the Viewfinder:

Set the lens at a selected lens opening on the f/stop ring. Depress the depth of field lever and observe the subject through the viewfinder. This will enable you to preview the area of sharpness in the picture before shooting.

Depth of Field Scale:

The depth of field scale indicates (after focusing) the approximate area that will be sharp in the picture. Locate on the depth of field scale the corresponding pair of f/stop figures. The distance between these two f/stop figures on the focusing ring will be the area of sharpness in your picture (Fig. 29).

NOTE · DO NOT DEPRESS THE SHUTTER RELEASE BUTTON WHILE DEPRESSING THE DEPTH OF FIELD LEVER.

Advanced Technique



THE SELF-TIMER

CE-4

SELF TIMER

Your Chinon CE-4 is equipped with a two stage electronic self timer with a red LED indicator.

The built-in self timer electronically delays the shutter release for 5 or 10 seconds. First select the desired delay by rotating the self timer control (Fig. 30). The camera should be mounted on a firm support during self timer operation. Now to activate the system simply depress the shutter release button.

Note : If the self timer is to be used with the camera set at "AUTO" then the camera eyepiece must be covered with eyepiece cover supplied as an optional accessory. This precaution eliminates extraneous light from influencing the meter system.

You will notice the red self timer LED blinking and two seconds before the shutter releases the flashing frequency will increase giving you or your audience time to smile. The self timer may also be utilized for releasing the shutter at low shutter speeds when a cable release is not available. If you decided not to use the self-timer or to change the delay time, you can cancel or reset the timer even after the function is initiated. Just return the dial to normal position for cancellation and reset the delay time again.

NOTE: CHANGE OF DELAY TIME CAN ONLY BE MADE AFTER CANCELLATION.



MANUAL EXPOSURE

By moving the shutter speed dial off the "AUTO" setting manual shutter speeds can be set. There are two methods of selecting the correct exposure.

1. Set the required shutter speed on the dial. While depressing the shutter release button until the meter activates, observe the flashing LED in the viewfinder. Rotate the lens aperture ring until the second LED aligns with the flashing shutter speed LED on the scale in the viewfinder (Fig. 31).
2. Set the required aperture on the lens. Depress the shutter release button until the meter activates and observe which shutter speed

is indicated in the viewfinder by an LED. You will also observe a flashing LED in the viewfinder. By adjusting the shutter speed until both LED's are coincident, correct exposure will result. If for special purposes it is necessary to either under or over expose the photograph, you can do so by rotating the lens aperture ring to bring the red exposure LED above the flashing shutter speed LED, this will result in over exposure. Conversely, if the red LED exposure indicator is adjusted to a position below the flashing red exposure LED under exposure will result.

MANUAL EXPOSURE (Cont.)

CE-4

The Manual Shutter speeds can be used for:

1. A particular shutter speed that is required and beyond the coupling range of the meter e.g. 4 sec. exposure at 3200 ASA.
2. Exposure compensation.
3. "B" ("Time" exposures longer than that possible in the auto mode).
4. Flash synchronization (1/60).



MULTIPLE EXPOSURE

MULTIPLE EXPOSURES

Another attractive feature of your Chinon CE-4 is the built-in unlimited multiple exposure provision. The multiple exposure lever is located in front of the film advance lever. When you activate the film advance lever simply press and hold the multiple exposure lever to the left. This lever should be held throughout the film advancement. By doing so the film advance mechanism and the film counter will be disengaged. Only the shutter will be charged when the film advance lever is activated. Therefore, the film will not advance and you can make unlimited multiple exposures on any single frame.

NOTE: YOU CAN MAKE MULTIPLE EXPOSURES AS MANY TIMES AS YOU WISH. HOWEVER, EACH TIME THE MULTIPLE EXPOSURE LEVER MUST BE HELD BEFORE AND THROUGHOUT THE FILM ADVANCEMENT.

THE EXPOSURE MEMORY

CE-4

EXPOSURE MEMORY

Under normal circumstances your Chinon CE-4 camera will produce perfectly exposed photographs, due to the integrated automatic exposure circuit. However, some lighting conditions might occur that could misguide the system, such as subjects with a very high contrast or strongly back-lit scenes. In such cases the exposure memory feature should be used.

1. Focus the Subject. Make sure that the shutter speed dial is set to the "AUTO" position.
2. Depress the shutter release button half way and measure the light on the main part of the subject you want to shoot excluding all unnecessary light from the side

or background (Fig. 34, 35, 36). Then press the exposure memory button which will instantly memorize the light value on the subject (Fig. 37 and 38).

3. Holding the exposure memory button depressed, compose the subject in the viewfinder as you desire (Fig. 39). Then press the shutter release button all the way to take the photograph.

The shutter speed indicator (LED) in the viewfinder will flash signaling while holding the exposure memory button depressed.



EXPOSURE COMPENSATION

EXPOSURE COMPENSATION

Your Chinon CE-4 camera incorporates an exposure compensation dial which can be utilized for special purposes such as bracketing exposures, compensation for back-lit or spot-lit situations. If you would prefer darker or lighter pictures than those obtained by the automatic exposure, this feature is very helpful. You can change the exposure factor up to one full stop either plus or minus in 1/3 EV increments. Depress the ASA lock button and turn the ASA selector dial to the desired position (Fig. 40).

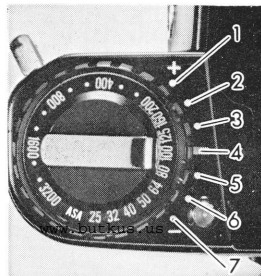

- (1) — 1EV over
- (2) — 2/3EV over
- (3) — 1/3EV over
- (4) — Normal exposure
- (5) — 1/3EV under
- (6) — 2/3EV under
- (7) — 1EV under

NOTE: AFTER EXPOSURES HAVE BEEN MADE, BE SURE TO RETURN THE DIAL TO THE NORMAL EXPOSURE POSITION.

THE FLASH SYSTEM

CE-4

CHINON DEDICATED FLASH SYSTEM

Specially designed and developed automatic flash units are available for your Chinon CE-4 as accessories. This highly advanced dedicated flash system permits carefree flash photography. You no longer have to alter the shutter speed dial from the auto position since the flash is integrated electronically with the camera body. Set the f/stop indicated on the exposure calculator dial of your Chinon flash to the corresponding aperture ring on the lens. A few seconds after your Chinon flash is turned to the

on position the flash-ready light will illuminate. Your Chinon CE-4 has a special viewfinder ready-light system which is electronically coupled to the auto flash. When the flash has reached adequate power the viewfinder 1/60 sec. shutter speed indicator (LED) will flash signaling the camera and flash are ready to operate (Fig. 41). After the picture has been taken and before the flash has recycled, the camera will automatically switch to the automatic mode until the strobe has once again recycled.

In this case, your flash must be set to the "AUTO" position.



THE FLASH SYSTEM (Cont.)

Other electronic flash units can be utilized with your Chinon CE-4 camera. However, if they do not incorporate a built-in hot-shoe, a P.C. cord must be connected to the "X" synchronization terminal on your CE-4 for proper flash synchronization. Also the shutter speed dial must be set to the 1/60 sec. flash synchronization position (Fig. 42 and 43).

NOTE: WHEN "FP" OR "M" TYPE FLASH BULBS ARE USED, THE SHUTTER SPEED MUST BE SET TO 1/15 sec. USE OF A TRIPOD FOR LOW SHUTTER SPEED PHOTOGRAPHY IS ALWAYS RECOMMENDED.

Always refer to the instructions enclosed with your electronic flash for additional operating instructions.



AUTO S-280 (Guide No. 28 :
M-ASA 100)



AUTO S-240 (Guide No. 24 :
M-ASA 100)



AUTO S-180
(Guide No. 18 :
M-ASA 100)

Chinon Power Winder

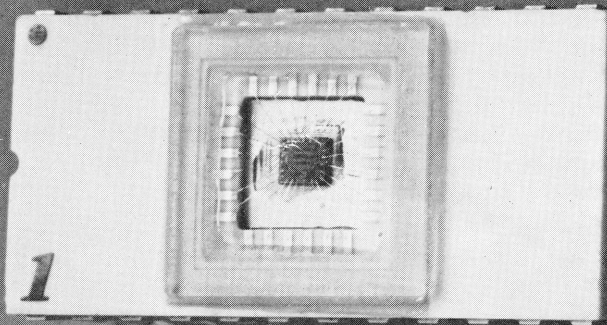



POWER WINDER

CHINON POWER WINDER (PW-530)

Your Chinon CE-4 compact single lens reflex camera can also be used with the new Chinon Power Winder when motorized photography is desired. This sophisticated accessory enhances the versatility of your new camera and opens up new horizons for creative photography (Fig. 44).

The Power Winder, designed with latest electronic technology, employs a special computer "memory" chip which monitors key functions essential to motorized photography (Fig. 45).

Single Frame Mode:

The Power Winder has a built-in shutter release button which can be conveniently used to trip the camera's shutter mechanism (Fig. 46). However, should you desire, the camera's shutter release can also be employed to take the picture. The Power Winder can also be coupled with an accessory remote control device (Fig. 47).

POWER WINDER (Cont.)

GE-4

Continuous Mode:

Outstanding "hi-speed" effects such as subjects moving or changing expressions can be caught on film. Couple this feature with the unique pre-set counter and electronic interval timer features and you can do almost anything photographically with your new Chinon camera (Fig. 48).

Pre-Set Counter:

The special "memory" chip monitors a preselected amount of exposure - up to 24 frames - at a set of a dial (Fig. 49).



POWER WINDER (Cont.)

Interval Timer:

Time lapse photography at your fingertips. By means of a built-in "unique" memory chip it is now possible to make exposure up to 30 seconds apart (Fig. 50).

It is possible to photograph just the same as in normal photography even when your Power Winder is attached to your new Chinon camera.

1. The C/S dial of the Power Winder should be turned to the off position so that frames are not accidentally exposed when the winder is installed to the camera body.
2. Insert the guide pin of the winder into the pin receptacle located on the bottom of the camera and

rotate the winder attachment screw clockwise until the winder is securely fastened to the camera body (Fig. 51).

NOTE: PLEASE MAKE SURE YOU READ THE INSTRUCTIONS PACKAGED WITH YOUR POWER WINDER FOR MORE OPERATING DETAILS AND OPERATING TECHNIQUES.

NOTE :

If you use Chinon Wireless Controller which is available as an optional accessory, you can control this Power Winder remotely at a distance of approx. 40 meters (13.12 Ft.).

Infra-red Photography

Your CE-4 camera will accept infra-red film.

To use Infra-red film an extra focusing adjustment must be made. After focusing note the figure that is adjacent to the red diamond on the distance scale (Fig. 52) then move that figure over to the infra-red mark engraved on the lens. This adjustment is only required for black and white infra-red film. When using color infra-red film, focus in the normal way.

NOTE: READ THE INSTRUCTIONS PACKED WITH THE INFRA-RED FILM FOR FURTHER INFORMATION.

Care of the Camera

Your Chinon CE-4 single lens reflex camera is a precision instrument. Used with care, it will provide years of service. Protect your camera from dirt, rain, dampness, and excessive heat. Avoid touching the lens. To clean the lens wipe it gently with a soft lintless cloth or lens tissue. Do not use eyeglass tissues as they might damage the lens coating.



ACCESSORIES

OPTIONAL ACCESSORIES FOR CHINON CE-4

*Standard Lenses

- 45mm f/2.8
- 50mm f/1.7
- f/1.7 multicoated
- 50mm f/1.4
- f/1.4 multicoated

*Wide-angle Lenses

- 28mm f/2.8 multicoated
- 35mm f/2.8 multicoated

*Telephoto Lenses

- 135mm f/2.8 multicoated
- 200mm f/3.3 multicoated

*Zoom Lenses

- 80-200mm f/3.8 multicoated MACRO
- 35-100mm f/3.5-4.3 multicoated MACRO

*Accessories

- Chinon Power Winder (PW-530)
- Chinon Auto S-180 flash
- Chinon Auto S-240 flash
- Chinon Auto S-280 flash

- Synchro-eye for flash (Slave Unit)
- Wireless Remote Control set for power winder
- Delux Carrying Case
- Neck Strap
- Filter (Skylite, UV, Y2, ND4X, PL)
- Pubber Eyepiece
- Eyepiece Adaptor (-3, +1, +3)
- Angle Finder
- 2 clips lens cap
- 1.5V Alkaline Battery (3 pcs. in one set)
- Rubber Lens hood
- Auto Extension Ring
- Bellows
- Mini Copy Stand
- Table Tripod
- Cable Release (13 inch)
- Remote Control Unit
- Spare ring for Mini Copy Stand
- Lens Mount Cap
- Body Cap



CHINON INTERNATIONAL CORP.

TOKYO, JAPAN

Printed in Japan
Imprimé au Japon