

This manual is for reference and historical purposes, all rights reserved.

This page is copyright© by M. Butkus, NJ.

This page may not be sold or distributed without the expressed permission of the producer

I have no connection with any camera company

On-line camera manual library

This is the full text and images from the manual. This may take 3 full minutes for the PDF file to download.

If you find this manual useful, how about a donation of \$3 to: M. Butkus, 29 Lake Ave., High Bridge, NJ 08829-1701 and send your e-mail address so I can thank you. Most other places would charge you \$7.50 for a electronic copy or \$18.00 for a hard to read Xerox copy.

This will allow me to continue to buy new manuals and pay their shipping costs.

It'll make you feel better, won't it?

**If you use Pay Pal or wish to use your credit card,
click on the secure site on my main page.**



GX680III / GX680IIIS Professional Professional

**OWNER'S MANUAL
BEDIENUNGSANLEITUNG
MODE D'EMPLOI
MANUAL DE INSTRUCCIONES**



Corresponding to the bar code system
Enspricht dem Strichcodesystem
Correspond au système de code à barres
Correspondiente al sistema de códigos de barras

OWNER'S MANUAL

This manual will show you how to use your camera correctly. Please follow the instructions carefully. Model GX680 III S is smaller than GX680 III, and only difference is that GX680 III S has no camera movement function while GX680 III has. In other words, both models can be used in the same manner except for the camera movements. Thus, we have made this Owner's Manual applicable to both models.

English (Pages 11~28)

See illustrations while you read this manual.

BEDIENUNGSANLEITUNG

Diese Anleitung enthält alles, was Sie über die Bedienung und Pflege Ihrer FUJI GX680 III Professional wissen müssen. Lesen Sie die Anleitung bitte aufmerksam durch.

Das Modell GX680 III S ist etwas kleiner als das Modell GX680 III. Außer ihrer Baugröße besteht der einzige Unterschied zwischen den beiden Modellen darin, daß die GX680 III S nicht über die Kameraverstellungs-Funktion der GX680 III verfügt. Mit Ausnahme des Kapitels "KAMERAVERSTELLUNGEN" gilt diese Anleitung daher gleichermaßen für beide Modelle.

Deutsch (Seite 29~48)

Orientieren Sie sich beim Durchlesen dieser Anleitung bitte an den Abbildungen.

MODE D'EMPLOI

Cette brochure est destinée à vous documenter sur l'utilisation correcte et l'entretien de votre appareil. Veuillez lire attentivement ces explications. Le modèle GX680 III S est plus petit que le GX680 III; la seule différence entre eux, c'est que le GX680 III S n'a pas la fonction de mouvements de l'appareil qu'offre le GX680 III. Autrement dit, à l'exception des mouvements de l'appareil, les deux modèles sont identiques et c'est pourquoi ce Mode d'emploi peut s'appliquer aux deux modèles.

Français (Pages 49~67)

Se reporter aux illustrations en lisant le mode d'emploi.

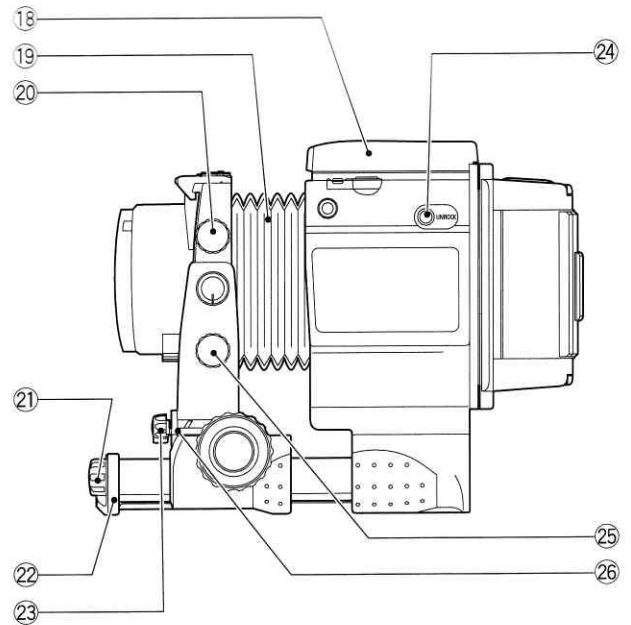
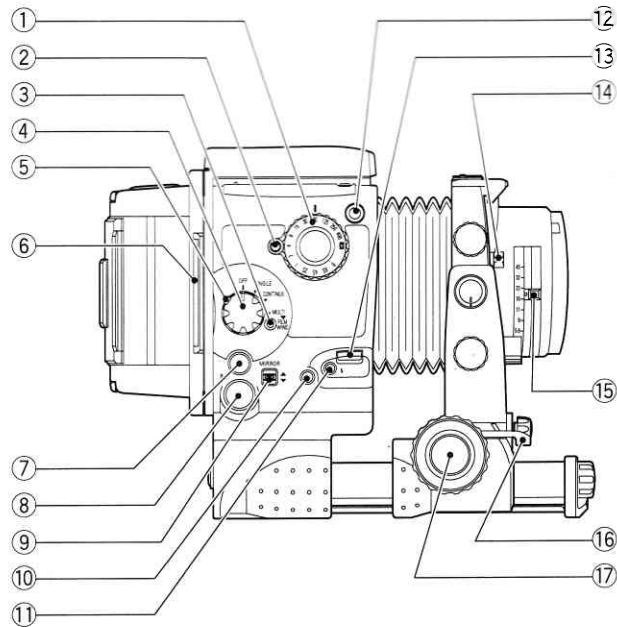
MANUAL DE INSTRUCCIONES

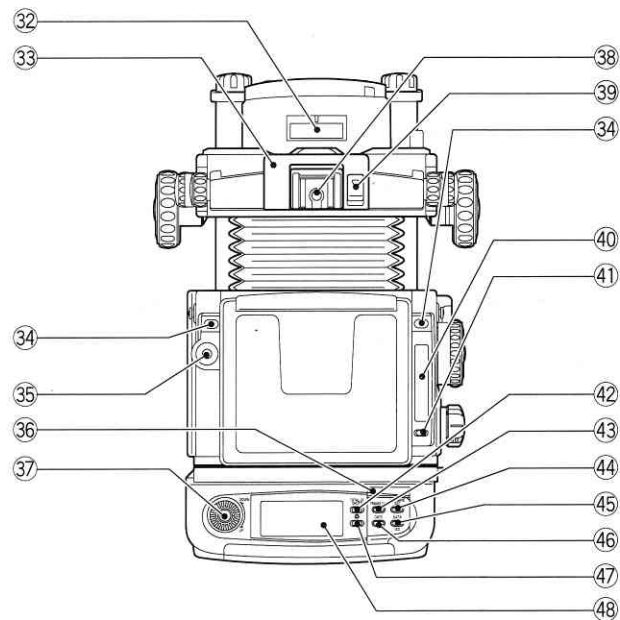
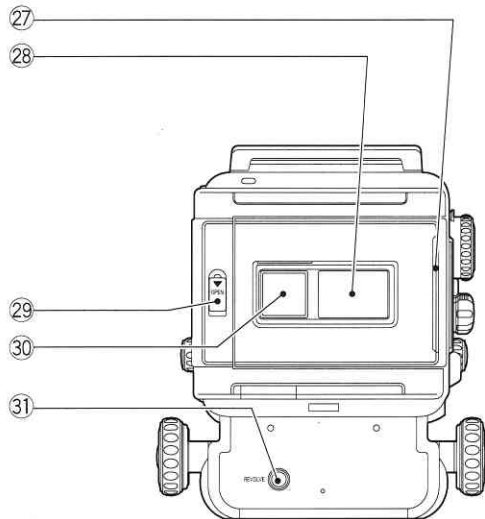
Este manual le indicará cómo emplear correctamente la cámara. Siga con atención las instrucciones. El modelo GX680 III S es más pequeño que el GX680 III, y la única diferencia es que el modelo GX680 III S no tiene la función de movimiento de la cámara que se incorpora en el modelo GX680 III. En otras palabras, ambos modelos pueden utilizarse del mismo modo excepto lo relacionado con los movimientos de la cámara. Por lo tanto, hemos preparado este manual de instrucciones para que sea aplicable a ambos modelos.

Español (Páginas 68~87)

Consulte las ilustraciones mientras lee este manual.

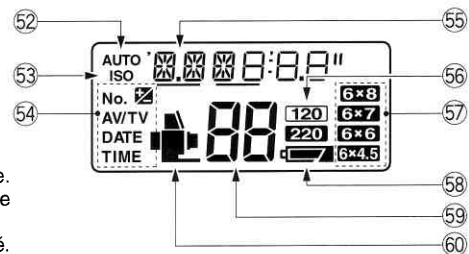
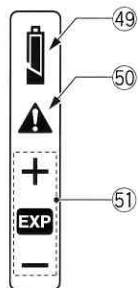
NAMES OF PARTS / BEZEICHNUNG DER TEILE / NOMENCLATURE / NOMENCLATURA





Camera Body Liquid Crystal Display (LCD)
Kameragehäuse-Flüssigkristallanzeige (LCD)
Affichage à cristaux liquides (LCD) du boîtier de l'appareil
Visualizador de cristal líquido (LCD) de la caja de la cámara

Film Holder III N Liquid Crystal Display (LCD)
Flüssigkristallanzeige (LCD) des Filmhalters Typ III N
Affichage à cristaux liquides (LCD) de porte-film III N
Visualizador de cristal líquido (LCD) del portapelicula III N



*The diagram shows all crystal displays in the "on" state.
 *Zur Erleichterung der Übersicht zeigt die Abbildung alle Anzeigen im eingeschalteten Zustand.
 *Le dessin présente tous éléments de l'affichage à l'état allumé.
 *El diagrama muestra todas las visualizaciones del LCD en el estado "activado".

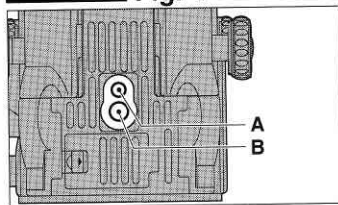
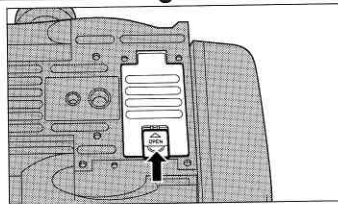
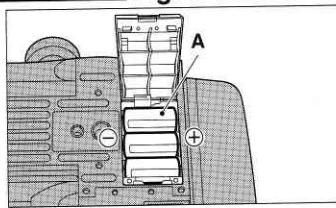
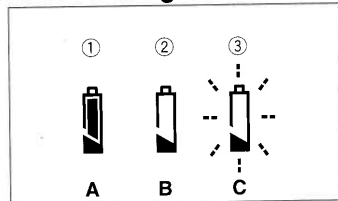
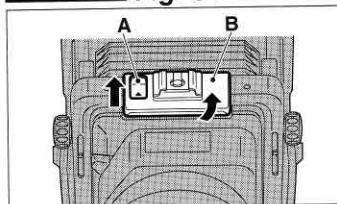
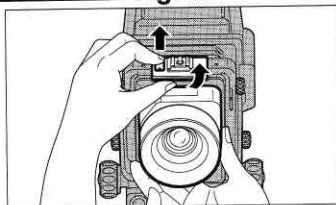
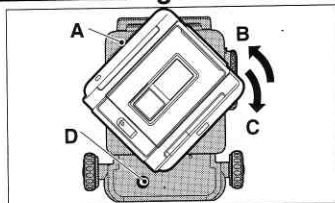
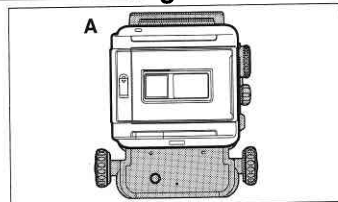
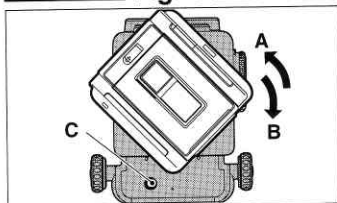
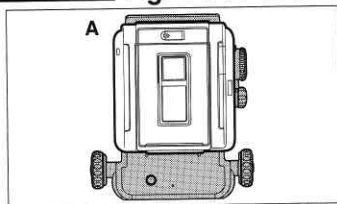
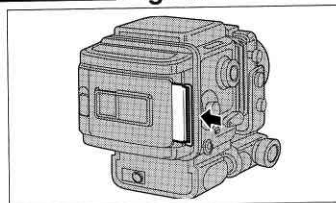
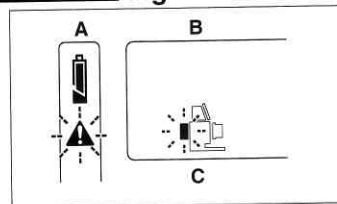
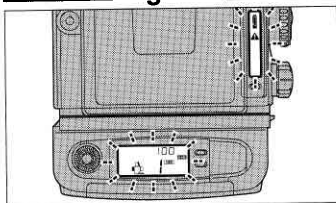
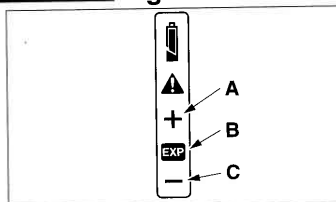
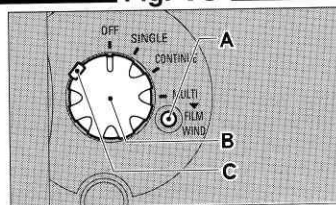
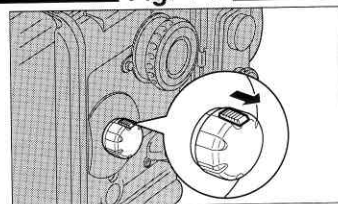
Fig. 1**Fig. 2****Fig. 3****Fig. 4****Fig. 5****Fig. 6****Fig. 7****Fig. 8****Fig. 9****Fig. 10****Fig. 11****Fig. 12****Fig. 13****Fig. 14****Fig. 15****Fig. 16**

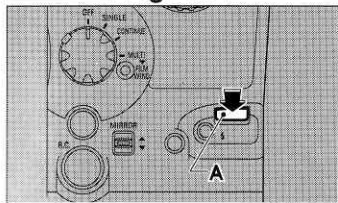
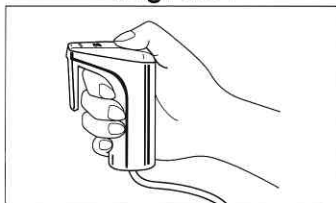
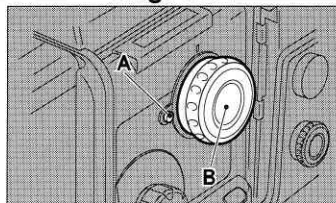
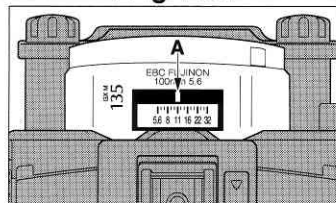
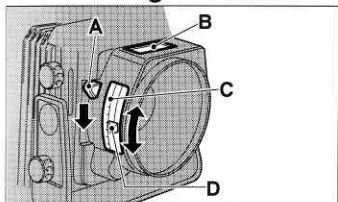
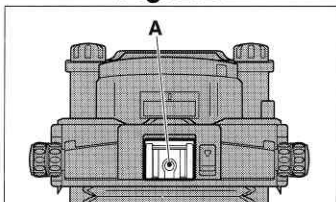
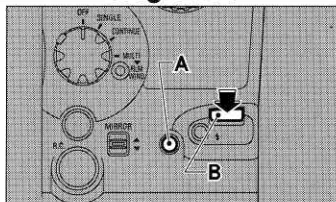
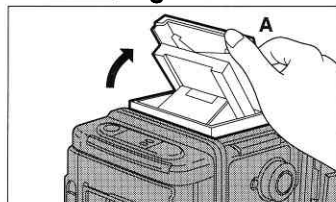
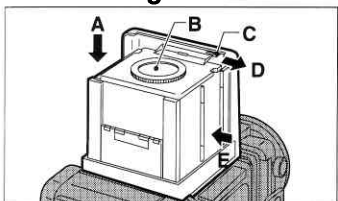
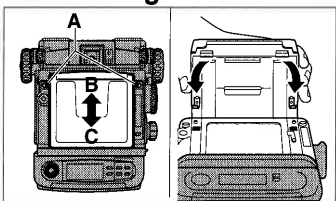
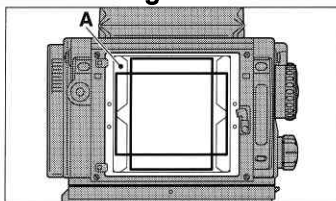
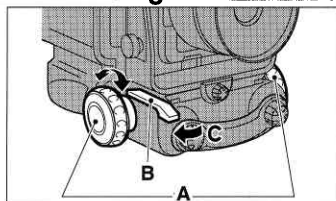
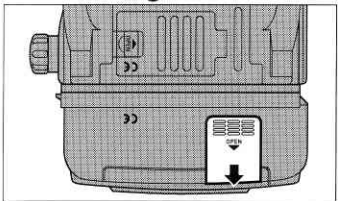
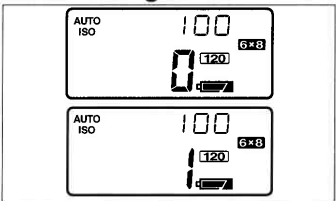
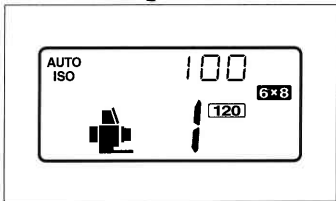
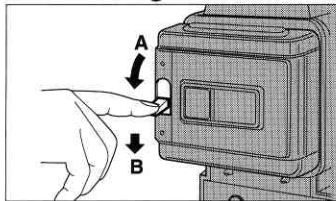
Fig. 17**Fig. 18****Fig. 19****Fig. 20****Fig. 21****Fig. 22****Fig. 23****Fig. 24****Fig. 25****Fig. 26****Fig. 27****Fig. 28****Fig. 29****Fig. 30****Fig. 31****Fig. 32**

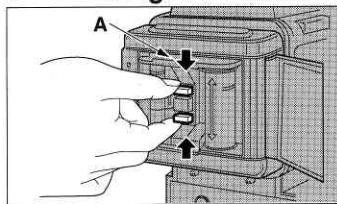
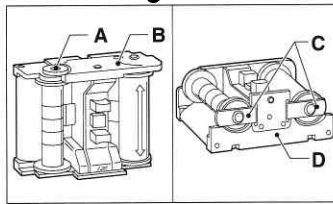
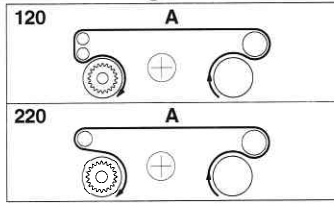
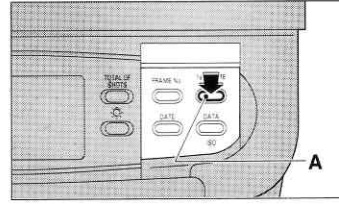
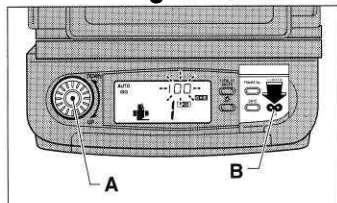
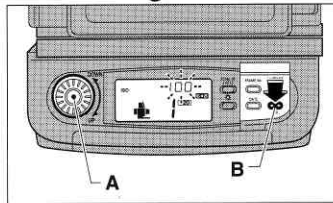
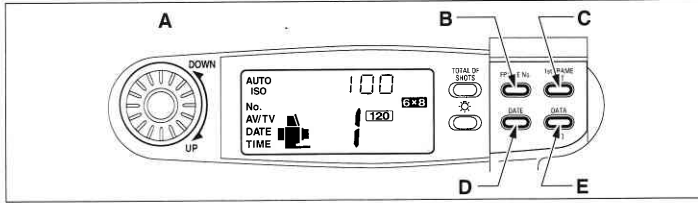
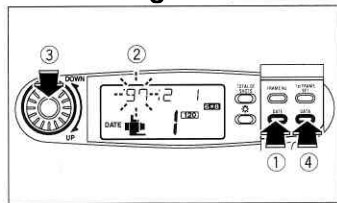
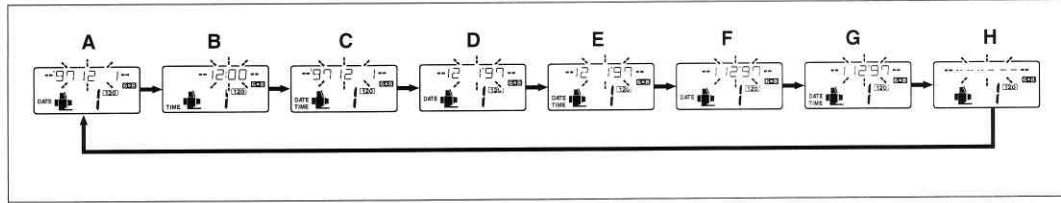
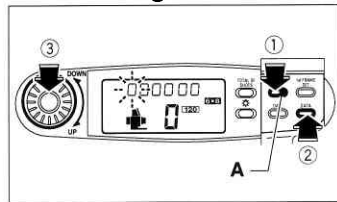
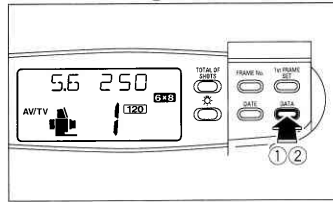
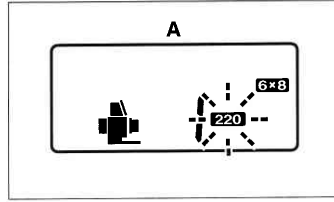
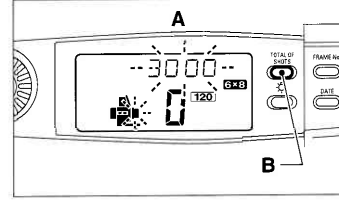
Fig. 33**Fig. 34****Fig. 35****Fig. 36****Fig. 37****Fig. 38****Fig. 39****Fig. 40****Fig. 41****Fig. 42****Fig. 43****Fig. 44****Fig. 45**

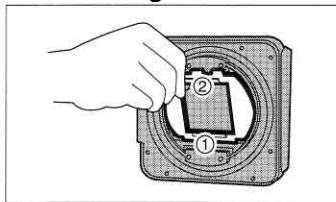
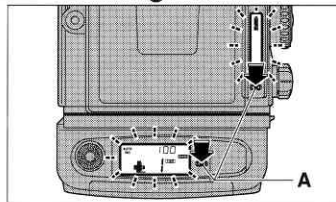
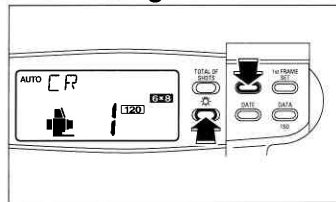
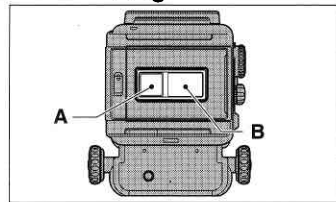
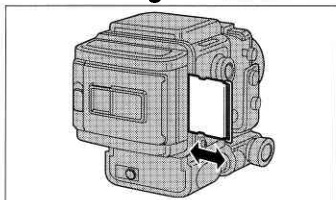
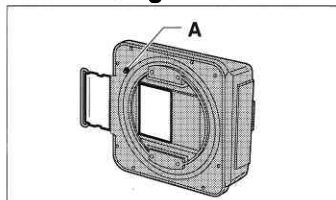
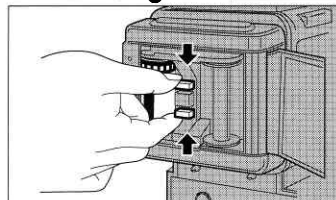
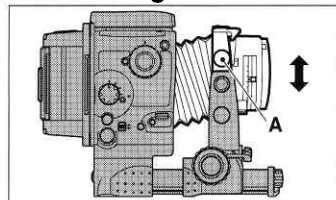
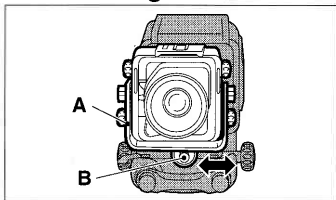
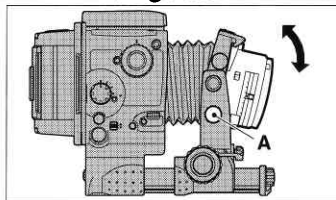
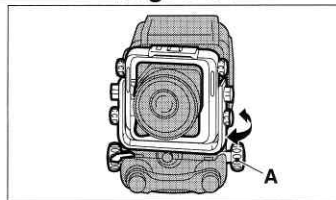
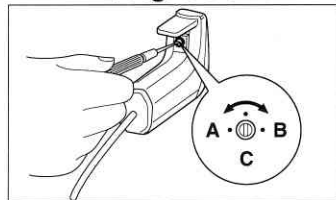
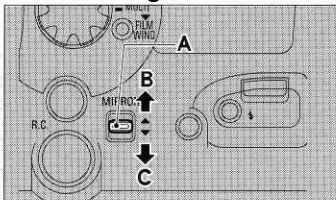
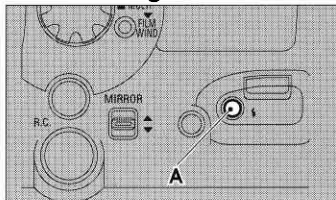
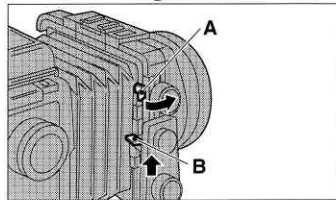
Fig. 46**Fig. 47****Fig. 48****Fig. 49****Fig. 50****Fig. 51****Fig. 52****Fig. 53****Fig. 54****Fig. 55****Fig. 56****Fig. 57****Fig. 58****Fig. 59****Fig. 60****Fig. 61**

Fig. 62

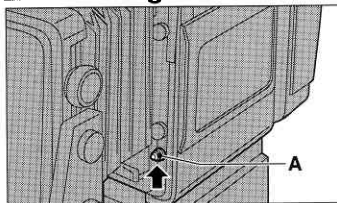


Fig. 63

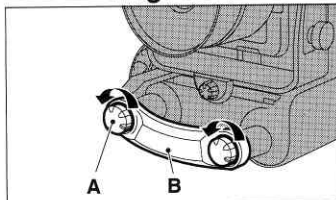


Fig. 64

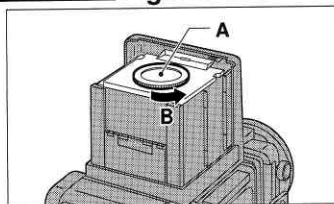


Fig. 65

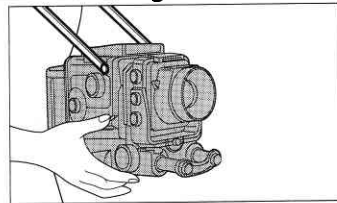


Fig. 66

