

 FUJIFILM

# GA645Z *i* Professional



Corresponding to the bar code system  
Entspricht dem Strichcodesystem  
Correspond au système de code à barres  
Correspondiente al sistema de códigos de barras  
對應於條形碼方式

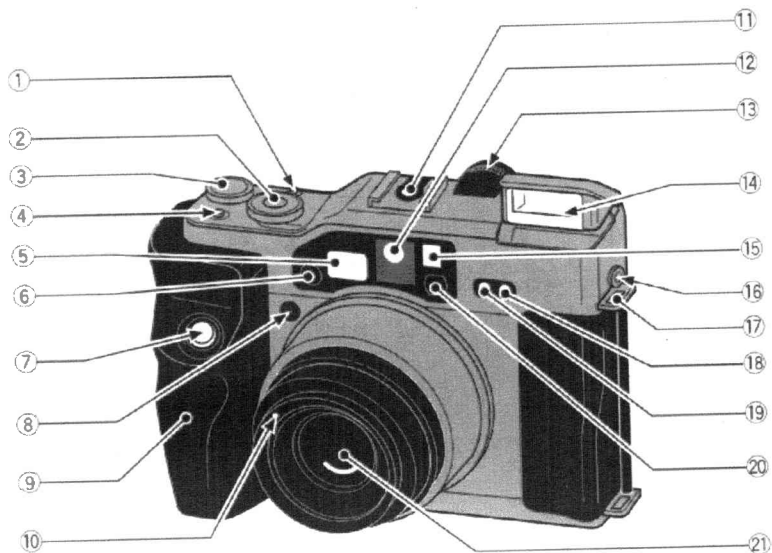
**OWNER'S MANUAL  
BEDIENUNGSANLEITUNG  
MODE D'EMPLOI  
MANUAL DE INSTRUCCIONES  
使用說明書**

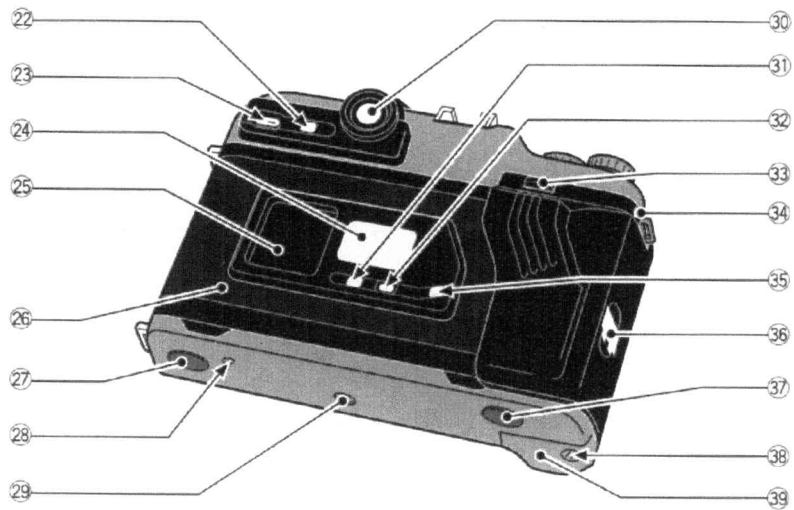
---

**English (Pages 12-31)**

See illustrations while you read this manual.

NAMES OF PARTS / BEZEICHNUNG DER TEILE / NOMENCLATURE / NOMENCLATURA / 部件名稱





**Liquid-crystal Display**  
**Flüssigkristallanzeige**  
**Affichage à cristaux liquides**  
**Visualización de cristal líquido**  
**液晶顯示屏**

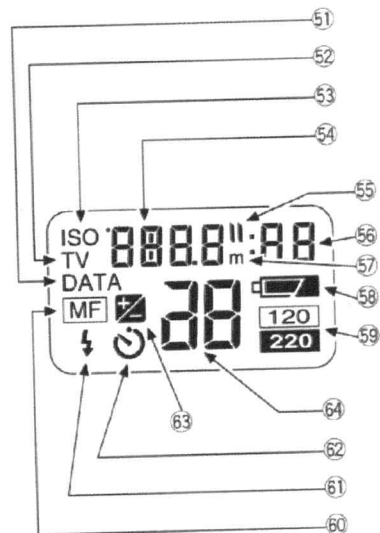
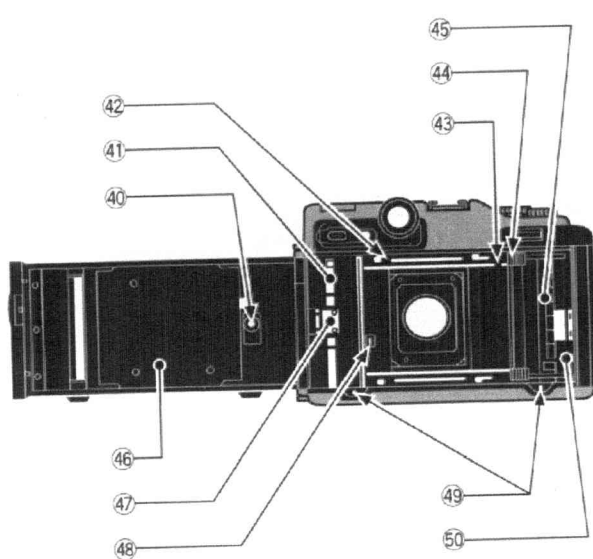


Fig. 1

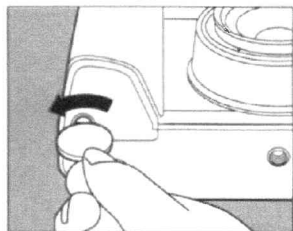


Fig. 2

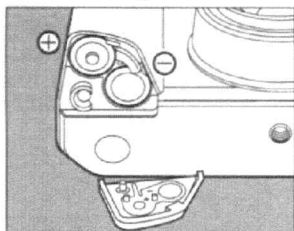


Fig. 3

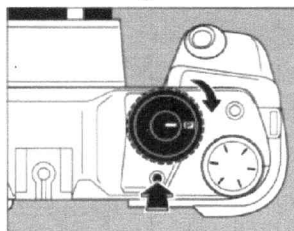


Fig. 4

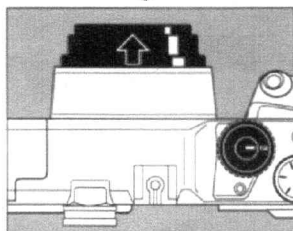


Fig. 5

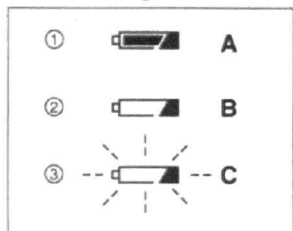


Fig. 6

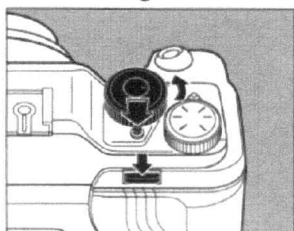


Fig. 7

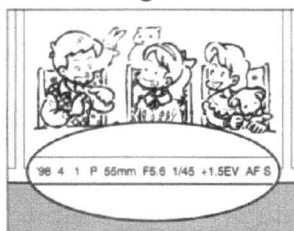


Fig. 8

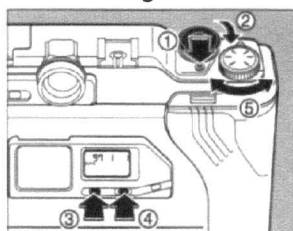


Fig. 9

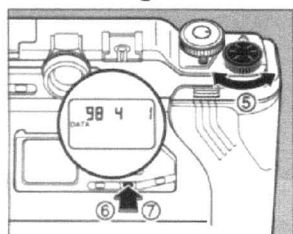


Fig. 10

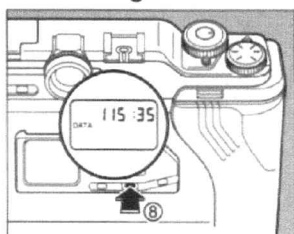


Fig. 11

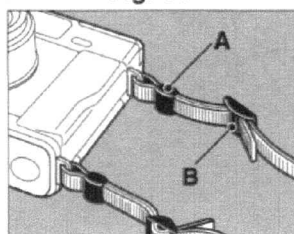


Fig. 12

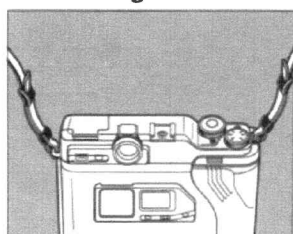


Fig. 13

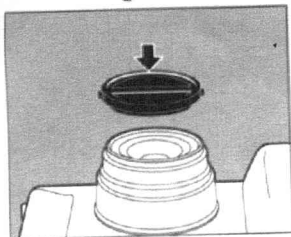


Fig. 14

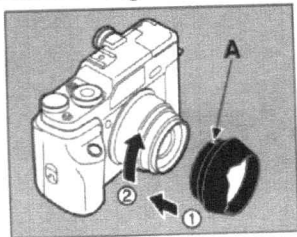


Fig. 15

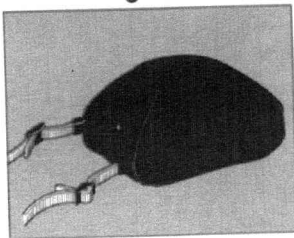


Fig. 16

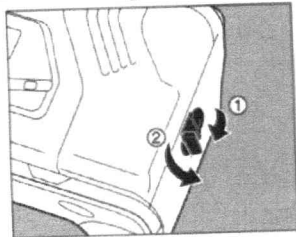


Fig. 17

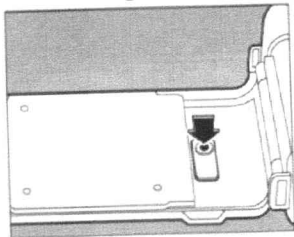


Fig. 18

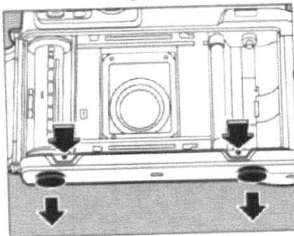


Fig. 19

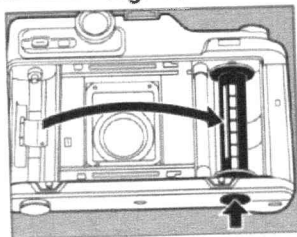


Fig. 20

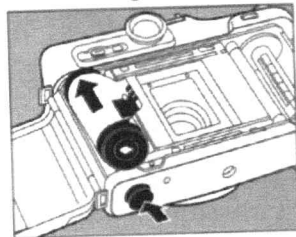


Fig. 21

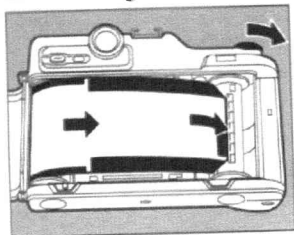


Fig. 22

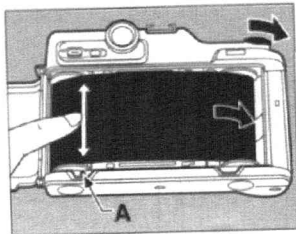


Fig. 23

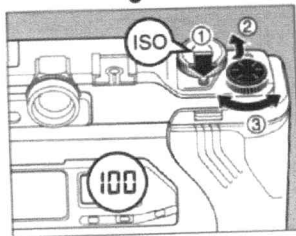


Fig. 24

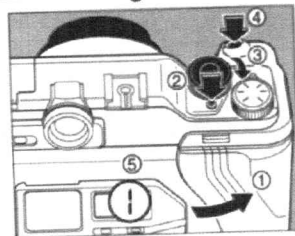


Fig. 25

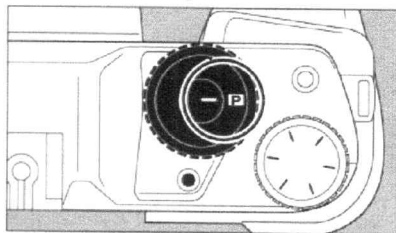


Fig. 26

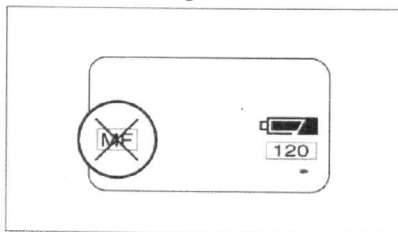


Fig. 27

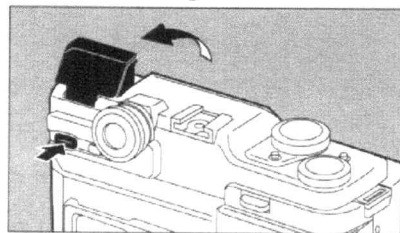


Fig. 28

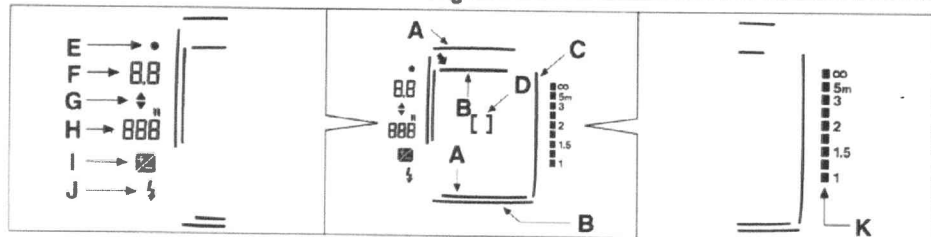


Fig. 29

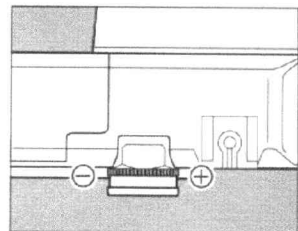


Fig. 30



Fig. 31

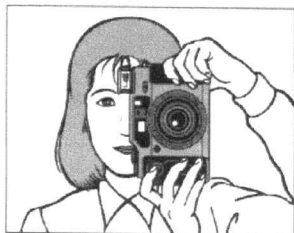


Fig. 32

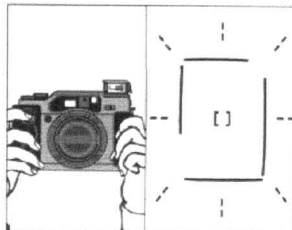


Fig. 33

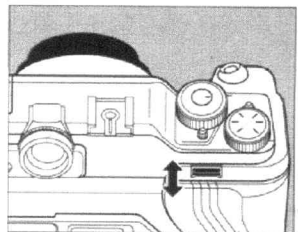


Fig. 34

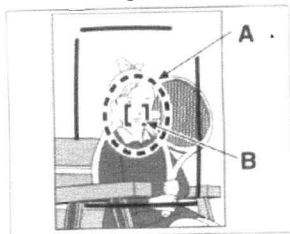


Fig. 35

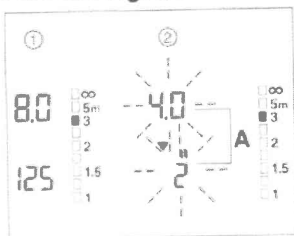


Fig. 36

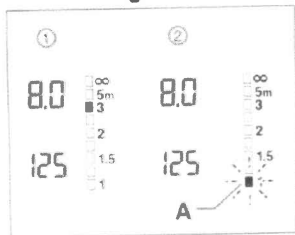


Fig. 37

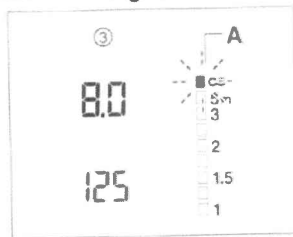


Fig. 38

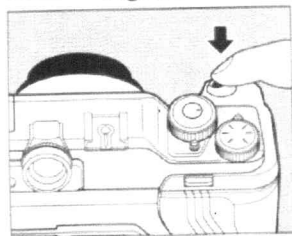


Fig. 39

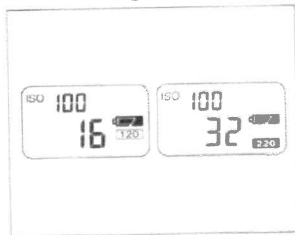


Fig. 40

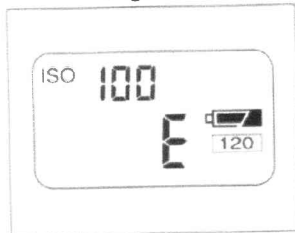


Fig. 41

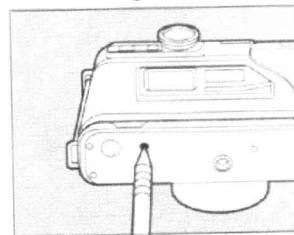


Fig. 42

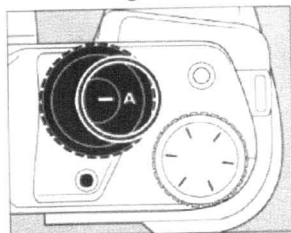


Fig. 43

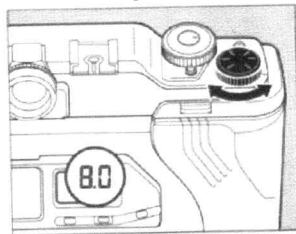


Fig. 44

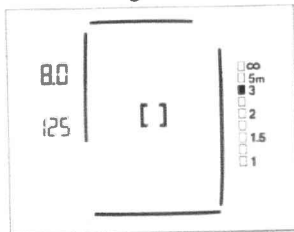
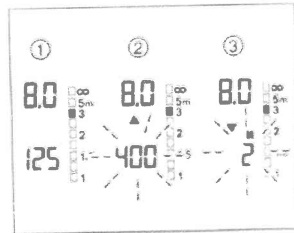


Fig. 45



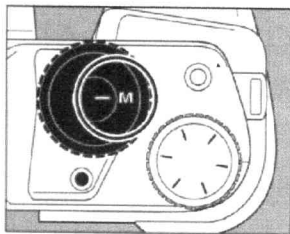
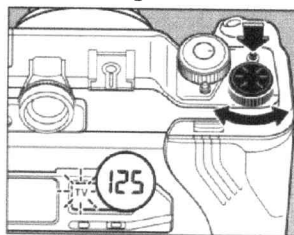
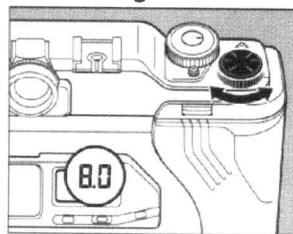
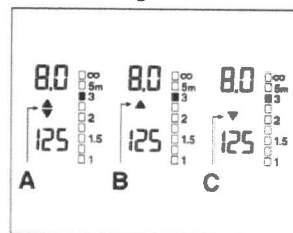
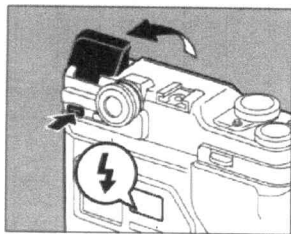
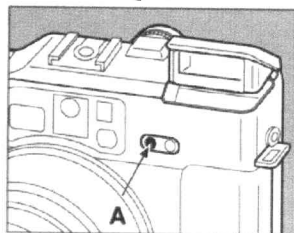
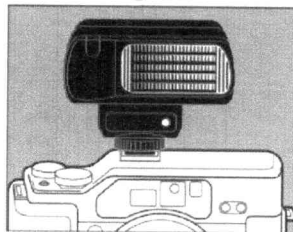
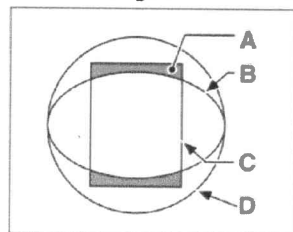
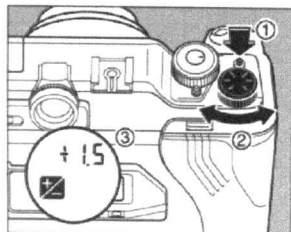
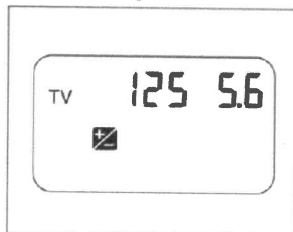
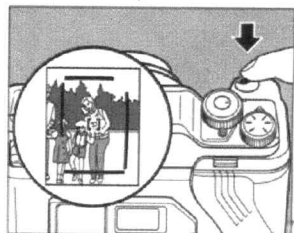
**Fig. 46****Fig. 47****Fig. 48****Fig. 49****Fig. 50****Fig. 51****Fig. 52****Fig. 53****Fig. 54****Fig. 55****Fig. 56****Fig. 57**

Fig. 58

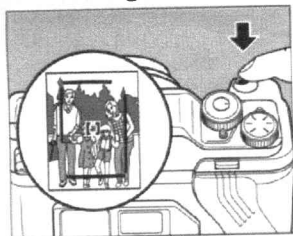


Fig. 59

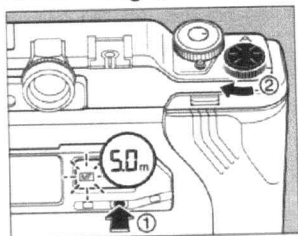


Fig. 60

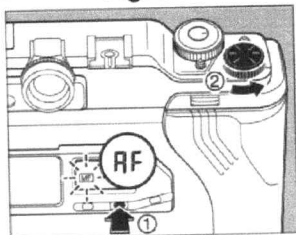


Fig. 61

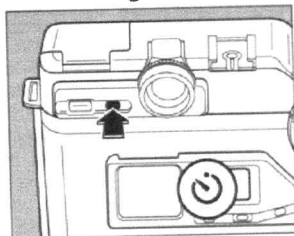


Fig. 62

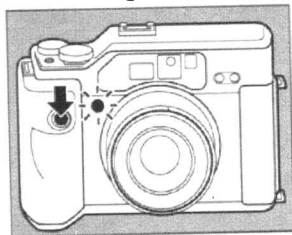


Fig. 63

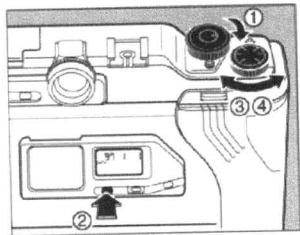


Fig. 64

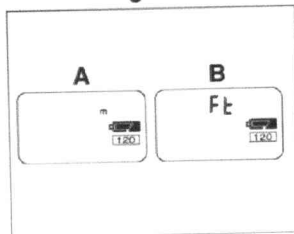


Fig. 65

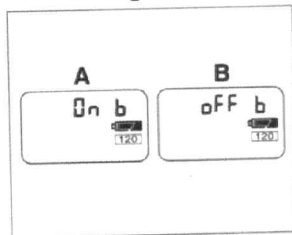
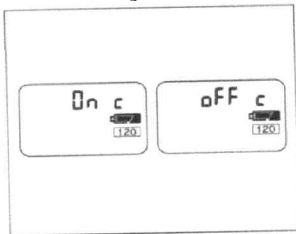
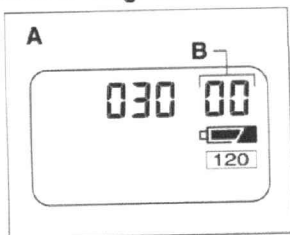


Fig. 66

Fig. 67



This manual will show you how to use your camera correctly.  
Please follow the instructions carefully.

## CONTENTS

Names of parts	12
Description of the functions of parts	13
Camera care and cautions	14
Special features	15
Specifications	16
I. Readyng the camera	17
Loading the batteries	17
Display and printing of data	18
Attaching the accessories	19
Loading the film	20
II. Basic procedures	22
Taking automatic-mode (autofocus/programmed auto exposure/automatic flash) pictures	22
Unloading the film	24
III. Advanced techniques	24
Aperture-priority auto exposure	24
Manual exposure	25
Using the built-in flash	26
Using an external flash	28
Exposure compensation	28
Using the focus lock	28
Manual focusing	29
Using the self-timer	29
IV. Extra functions	30
V. A word on the camera's autofocus system	31
Reference data	31

## NAMES OF PARTS

- ① Dial Lock Release
- ② Selecting Dial
- ③ Up/Down Dial
- ④ Exposure Compensation Button
- ⑤ Passive Autofocus Window
- ⑥ Active Autofocus Window (also serves as an AE light receptor)
- ⑦ Shutter Release Button
- ⑧ Self-timer Lamp
- ⑨ Camera Grip
- ⑩ Lens Cap Sensor
- ⑪ Hot-Shoe
- ⑫ Finder Window
- ⑬ Viewfinder Focus Adjusting Dial
- ⑭ Flash Head
- ⑮ Finder Light Intake Window
- ⑯ Sync Socket
- ⑰ Strap Lug
- ⑱ AE light Sensor
- ⑲ Flash Sensor
- ⑳ Active Autofocus Window
- ㉑ Lens
- ㉒ Self-timer Button
- ㉓ Flash Button
- ㉔ Liquid Crystal Display
- ㉕ Film Reminder Slot
- ㉖ Camera back
- ㉗ Film Loading Knob
- ㉘ Mid-roll Wind-up Button
- ㉙ Tripod Socket
- ㉚ Finder Eyepiece
- ㉛ Date Button
- ㉜ AF/M Button
- ㉝ Zoom Lever
- ㉞ Cable Release Socket
- ㉟ Light Button for the liquid Crystal Display
- ㊱ Camera Back Lock

- 37 Spool Loading Knob
- 38 Battery Compartment Cover Screw
- 39 Battery Compartment Cover
- 40 Pressure Plate Changeover Switch
- 41 Film Feed Chamber
- 42 Focal Plane Rail
- 43 Data printing Window
- 44 Film Wind Sensor Roller
- 45 Spool
- 46 Pressure Plate
- 47 Spool Pressure Spring
- 48 Film Sensor
- 49 Spool Shaft Buttons
- 50 Film Take-up Chamber

### Liquid Crystal Display (LCD)

This illustration shows all signs and indicators displayed in the LCD. Usually, only the information needed for each shot is displayed.

- 51 Data Printing Sign
- 52 Exposure Indicator
- 53 Film Speed Sign
- 54 Shutter Speed/Shooting Distance/Exposure Compensation/Film Speed Indicator
- 55 Seconds
- 56 F-number
- 57 Distance Unit Sign(m)
- 58 Battery Sign
- 59 Film Type Indicator
- 60 Manual Focusing Mode Sign (If this sign does not appear, the camera is set for autofocus)
- 61 Flash Sign
- 62 Self-timer Mode Sign
- 63 Exposure Compensation Mode Sign
- 64 Exposure Counter

## DESCRIPTION OF THE FUNCTIONS OF PARTS

### ● Selecting Dial

- (1) OFF: Power off – Set it to OFF when not using the camera.
- (2) P : Programmed auto exposure – For setting exposure (aperture and shutter speed) automatically.
- (3) A : Aperture-priority auto exposure – If you set the aperture, the shutter speed is set automatically. When the built-in flash is used, the shutter speed will not be slower than 1/45 sec.
- (4) As : Slow synchro-aperture priority auto exposure – If you set the aperture, the shutter speed is set automatically. (When the built-in flash is used, the shutter operates for the range from the high speed to 2 second slow shutter speed.)
- (5) M : Manual exposure – You can set your desired aperture and shutter speed.
- (6) ISO : To set the film speed, use this dial and the Up/ Down Dial.

### ● Up/Down Dial

This dial has the following functions:

- (1) Feeding of the film leader when loading film.
- (2) Aperture setting in the aperture-priority auto exposure mode. (Selecting Dial : A, AS)
- (3) Setting of aperture and shutter speed in the manual exposure mode.
- (4) Setting of the film speed. (ISO).
- (5) Selecting the autofocus or manual focusing mode
- (6) Setting of the shooting distance in the manual focusing mode.
- (7) Setting of the exposure compensating value (+/- EV) in the exposure compensation mode.
- (8) Setting of the date and time.

### ● Pressure plate changeover switch (120/220)

For setting the 120 or 220 film

### ● Exposure Compensation Button (■)

- (1) To compensate exposure, use it with the Up/Down Dial.
- (2) To choose a shutter speed for manual exposure, use it with the Up/Down Dial.

### ● Data Button (DATA)

Using this button and the Up/Down Dial, data (date, time, and exposure data) printing is set.

### ● AF/M Button

Using this button with the UP/Down Dial for Setting the shooting distance and autofocus.

### ● Self-timer Button (⊙)

For setting the self-timer mode.

### ● Flash Button (⚡)

For popping up and turning on the flash.

### ● Zoom Lever

For changing focal length toward the tele and wide.

## CAMERA CARE AND CAUTIONS

Your camera is a precision instrument. When handling it, take sufficient care and observe the following instructions.

### 1. Cleaning the camera

- Do not use solvents, such as thinner or alcohol, to clean your camera.
- Make it a habit to clean the camera before and after taking pictures. To clean it, dust off with an air blower and wipe the camera exterior with a soft cloth such as silicon cloth.
- Dust and soil inside the film chamber may damage your film. Take particular care to clean the camera interior.

### 2. Cleaning the lens

- Scratches on the lens surface can reduce its sharpness far more than you would think. If the contrast of your picture seems somehow insufficient and it does not look crisp enough, the possible cause is scratches on the lens surface. Clean the lens carefully in the procedure described below.

- ① Set the Selecting Dial to OFF.
- ② Blow off dust and debris from the lens surface with an air blower.
- ③ Moisten a sheet of lens cleaning paper with a commercially available lens cleaning fluid and wipe the lens gently with it in a circular motion. Always start from the center then gradually move

out to the edges.

- ④ Finally, after all contaminants have been removed, wipe off the remaining lens cleaning fluid with a dry sheet of lens cleaning paper. Again, start from the center in a circular motion then move out to the edges.
- Breathing a mist on the lens surface then wiping it with silicon cloth or other similar material is the worst thing you can do. Never do it because this is one of the main causes of scratches on camera lenses.
  - Clean the Autofocus Window and Finder in the same way as described above for the lens. Scratches on the Autofocus Window can cause incorrect focusing.

### 3. Liquid crystal display

- Though the liquid crystal display may sometimes look black at a high temperature around 60 °C, it will return to normal at an ordinary temperature.
- At low temperatures, the response speed of the liquid crystal display tends to become slower. But this is a natural characteristic of the liquid crystal and it does not mean anything wrong.

### 4. Battery note

- Though battery performance will generally be reduced by low temperatures, it will return to normal at an ordinary temperature. If you are shooting in cold weather, be sure to use new batteries and keep spare batteries on hand and, while warming them in a pocket, use these batteries alternately. If the battery power is low, the camera may will not operate at low temperatures.
- If the Battery Sign (⚡) switches to the Battery Low Sign (⚡), you should change the batteries soon. Take spare batteries along with you.
- Never dismantle the batteries, heat, throw into fire, charge or cause them to short circuit.

### 5. The working temperature range

- The working temperature range for this camera is -10°C to +40°C.

## 6. Storage precautions

- In hot weather, do not leave your camera in a closed compartment of your car, or on an ocean beach and in moist places except temporarily for a very short time.
- Keep the camera where it will be safe from moisture, heat, and dust. Be sure to put the lens cap on the lens.
- Do not store it in a wardrobe drawer because the gas of naphthalene or other insecticides can cause damage to the camera and film.

## 7. Film loading and unloading

- Always load and unload film in subdued light.

## SPECIAL FEATURES

- **A fully automatic, 6 × 4.5 cm format autofocus zoom camera (Corresponding to the bar code system)**

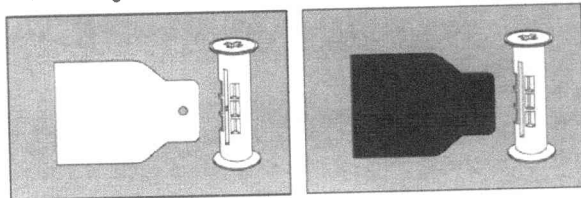
- ① Super EBC Fujinon 1:4.5 f=55 mm ~ 1:6.9 f=90 mm 1.6× zoom lens promises sharp and clear pictures with high image quality from wide to tele.
- ② Use of film with the bar code system eliminates erroneous film settings and prevents erroneous use of film.
  - Automatic film speed (ISO) setting
  - Automatic pressure plate setting (automatic focal plane adjusting, automatic exposure counter interlocking, automatic film type indication on the LCD panel)
- ③ Equipped with the Lens Cap Sensor - Preventing an erroneous exposure with the lens cap on.
- ④ The LCD equipped with an EL back light - Easily checked displays even in the dark
- ⑤ Hybrid autofocus system (passive type with external light (sensing phase contrast) and active type with infrared rays (sensing infrared rays)) backs up the Super EBC Fujinon lens to bring its high performance into full play.

## ● What is a "Bar Code System"?

The film speed (ISO), type of the film (120/220), and other data are recorded in a bar code format on the seal which connects the leader paper with the film. The Fujifilm's bar code system allows the camera reading this bar code and setting the film speed and type of the film automatically.

## ● Easy-loading film

This system allows the film to be easily and correctly loaded simply by inserting the leader paper into the slot on the take-up spool. To be more specific, the round opening in the leader paper head is hooked to the claw on the slot of the take-up spool. The leader paper is properly stretched preventing the roll from slackening and the film is loaded completely.



Easy-loading film

Conventional film

## SPECIFICATIONS

- **Type**  
Fully automatic, 6 × 4.5 cm format autofocus zoom camera (corresponding to the bar code system)
- **Picture Size**  
6 × 4.5cm format (actual picture size: 56 × 41.5 mm)
- **Film**  
120 (16 exposures) and 220 (32 exposures) roll film.
- **Lens**  
Super EBC Fujinon 1:4.5 - 6.9 f=55 - 90 mm lens (10 components, 10 elements), equivalent to 34 - 56 mm on 35 mm format, 65 - 42° angle of view, 1.0 m minimum focusing distance, 52 mm filter diameter.
- **Focusing**  
Hybrid (active type and passive type) autofocus system, 1.0 m - ∞ focusing range, switchable to manual focusing mode, provided with focus lock.
- **Finder**  
Illuminating window type bright frame finder, automatic parallax correction, 88% field of view at infinity (∞), 90% at 3 m, 0.4 - 0.58× magnification.
- **Display in the Finder**  
Picture frame (bright frame), autofocus sign, data display: aperture value, correct-exposure sign (♦), shutter speed, flash activation, shooting distance, distance unit (m). Shutter actuated display.
- **Shutter**  
Electronic, programmed auto-exposure interlens shutter (exposure settings on aperture-priority auto exposure and manual exposure are also possible), provided with buzzer for indicating that the shutter has tripped.
- **Shutter Speed**  
B, 2 sec. - 1/700 sec.
- **Self-timer**  
Electronic self-timer with 10 sec. delay, provided with countdown lamp.
- **Exposure Control**  
Center-weighted light metering (SPD photocell), programmed auto exposure, A, AS: aperture-priority auto exposure, manual exposure, EV 3 - 19 coupling range (ISO 100).
- **Exposure Compensation**  
±3 EV in 1/2-stop increments.
- **Film Speed Setting**  
ISO 25 - 1600 in 1/3-step increments.  
Automatically set with a bar code system film loaded.
- **Flash**  
Built-in, pop-up type flash, automatic control of amount of light, guide number 12 (ISO 100).
- **Film Advance**  
Automatic first-frame positioning (alignment of start mark is not necessary), automatic winding, provided with buzzer for indicating the last frame, film is automatically wound up after the last frame is exposed.
- **Exposure Counter**  
Additive type counter on liquid crystal display, interlocked with 120/220 pressure plate switchover, "E" sign appears after the last frame is exposed.
- **Liquid Crystal Display (LCD)**  
Number of exposures, shutter speed, aperture, film speed, type of film (120 or 220), battery warning sign, flash activation sign, exposure compensation mode sign, self-timer mode sign, manual focusing mode sign, date and time (Year Month Day/Day Hour Minute), shooting distance, total shots indicator.
- **Data Printing**  
Printing outside the picture frames, dates (Year Month Day/Hour Minute), exposure data (exposure mode, aperture, shutter speed, exposure compensating value, AF/MF.)
- **Others**  
Hot-shoe, film reminder slot, cable release socket, sync socket, tripod socket, provision for switching on and off buzzer sound. Lens cap warning.
- **Power Source**  
Two CR123A/DL123A lithium batteries; about 1600 shots can be taken without flash.

● **Dimensions**

161.5 (W) × 108.5 (H) × 73 (D) mm.  
(Dimensions when the lens barrel is retracted)

● **Weight**

885 g (without batteries).

● **Accessories**

Camera soft case, neck strap, lens hood, lens cap, batteries (two).

\* Specifications and performance are subject to change without notice.

## I. READYING THE CAMERA

### LOADING THE BATTERIES

**1. Open the battery compartment cover (Fig. 1)**

Set the Selecting Dial to OFF and, with a coin, turn the Battery Compartment Cover Screw toward the arrow to pen the Cover.

**2. Insert the batteries (Fig. 2)**

Insert the batteries in the Battery Compartment with the plus (+) and minus (-) ends as illustrated inside the Cover, then replace the cover and tighten it with a coin.

● Use two 3V CR 123A/DL 123A Lithium batteries.

● The camera will not operate unless the batteries are correctly loaded.

● Change the two batteries at the same time and always use new batteries. Do not mix new and old ones.

**3. Check the batteries (Fig. 3, 4)**

While pressing in the Dial Lock Release, turn the Selecting Dial from OFF to "P" (or "A" or "As" or "M"). If the Lens moves out into shooting position, the batteries are loaded correctly.

**4. Condition of batteries (Fig. 5)**

● Indicator lights (Fig. 5-A)

● Indicator lights (Fig. 5-B)

● Indicator flickers (Fig. 5-C)

① The battery capacity is normal.

② The battery capacity is low. Replace the batteries with new ones.

③ Since the battery capacity is low, the shutter lock is applied. Replace the batteries with new ones.

● A pair of new batteries will provide power for taking about 1600 shots without flash, and about 450 shots when half of the pictures are taken with flash (as tested according to Fujifilm's battery testing procedure).

## DISPLAY AND PRINTING OF DATA

- This camera incorporates a data printing unit which allows you to print the date, time, and exposure data outside the picture frames on your film.

### 1. Changing the data format

Data Format	Display on LCD (Example)	Printing (Example)
<p>Printing off</p> <p>↓</p> <p>Year Month Day*1</p> <p>↓</p> <p>Day Hour Minute</p> <p>↓</p> <p>Exposure Data</p> <p>↓</p> <p>Year Month Day/Exposure Data</p>	<p>--- -- --</p> <p>'98 4 1</p> <p>1 15:35</p> <p>TV 45 56</p> <p>Shutter speed ↑      ↓ F-number</p> <p>'98 4 1 TV 45 56</p> <p>← Blinks alternately →</p>	<p>'98 4 1</p> <p>1 15:35</p> <p>Program mode Displayed when the built-in flash fires. →</p> <p>P 55mm F5.6 1/45 +0.5 EV AF S</p> <p>Shooting focal length.      ↑      ↑      ↑      ↑</p> <p>F-number      Shutter speed      Exposure Compensation      AF/MF</p> <p>'98 4 1 P 55mm F5.6 1/45 +0.5 EV AF S</p>

After changing the batteries, the data format is initially set to " - - - - - " (printing off). Each time you press in the Data Button, the arrangement of data will change as shown above. If your desired format appears, stop operating it.

The display of the data in the format which you have set will turn on for five seconds after you remove your finger from the Button, then turn off. The [DATA] Sign in the LCD will remain on to tell you that the camera has been set to the data printing mode.

- \* The "Year Month Day/Exposure Data" will blink alternately because all of these data cannot be displayed in the LCD at the same time.
- \* When the exposure compensation has been set, the compensated values of aperture and shutter speed will be displayed.

\* When the shutter speed is set to "Bulb", "bul." will be displayed on the LCD, and "BULB" will be printed as the exposure data.

\* 1: Changing the data format; Data mode column. Year Month Day can be changed in the following sequence whenever the Selecting Dial is set from OFF to ISO with the Zoom Lever pressed downward (Wide angle side). (Fig. 6)

→ Month Day Year → Day Month Year → Year Month Day

When the date is set once under a selected mode, the mode will last until it is changed again.

## 2. Data printing example (Fig. 7)

Data under the set mode (date and exposure data) are indicated outside the picture frames on your film. The printed exposure data are exposure mode, focal length, aperture, shutter speed, exposure compensation value, focusing mode (automatic or manual) and flash used or not.

\* When the flash fired, "S" will be printed. When the flash is turned on under the P mode but the light is so bright that the flash is not required, "S" will not be printed.

## 3. Set the date (Fig. 8, 9)

- ① Pressing in the Dial Lock Release;
- ② Set the Selecting Dial to "P" (or "A" or "As" or "M").
- ③ Pressing in the Data Button, press in the AF/M Button.
- ④ The Year number will blink. When the Year number has started blinking, you may leave your finger from the Data Button.
- ⑤ Set the blinking Year number correctly with the Up/Down Dial.
- ⑥ Press in the AF/M Button to complete the Year setting. The next number (Month) will then blink. Set the number correctly as described in ⑤ above.
- ⑦ As the AF/M Button is pressed in, set numbers will be shifted from Month to Day, from Day to Hour, and from Hour to Minute. Set the numbers correctly with the Up/Down Dial.

## 4. Set the time (Fig. 10)

- ⑧ Set the correct Minute as described above, and press in the AF/M Button. Second will be zero-set, the film speed (ISO) will be displayed, and thus, time setting ends.
- \* The correct date will be displayed up to the year 2030.  
\* When the batteries are replaced with new ones, the set data are erased. Be sure to reset the data.

## ATTACHING THE ACCESSORIES

### 1. Attach the neck strap (Fig. 11, 12)

- Anti-loosening Ring (Fig. 11-A)
- Buckle (Fig. 11-B)

Your camera has three Strap Lugs, and you can attach the neck

strap either vertically or horizontally.

- ① Pass both ends of the strap through the Strap Lugs.
  - ② Adjust the strap length properly with the Buckle.
- When you pass the strap ends through the Anti-loosening Rings, slide the Anti-loosening Rings. The strap ends will pass through the them more easily.

### 2. Put on the lens cap (Fig. 13)

Take two buttons on the lens cap with your fingers to put it on or off.

To prevent accumulating dust and other foreign matters on the lens glass, put the lens cap on as soon as you are through taking pictures. To clean the lens, refer to "Cleaning the lens" on page 14.

### 3. Put on the lens hood and filter (Fig. 14)

- Indicator (Fig. 14-A)

#### [Lens Hood - Bayonet type]

Place the indicator on the lens hood upward as shown in the figure, put the hood into the front of the lens barrel and turn it to the right till it is locked.

- The lens hood has been designed especially for your camera. Be sure not to use the lens hood other than that comes with your camera. If you use other hoods, Fujifilm cannot guarantee correct autofocus because light may fall off along the picture edges or the autofocus beam may be blocked.

#### [Filter]

Use commercially available 52 mm diameter filters. The filter is mounted by screwing it into the front of the lens barrel.

- Do not put on two or more filters. Fujifilm cannot guarantee correct autofocus because light may fall off along the picture edges.
- When taking pictures by using filters with exposure factors, be sure to compensate exposures accordingly with the exposure factors.

### 4. Use the soft case (Fig. 15)

Always try to keep your camera in the Soft Case when carrying it about or storing. Such a habit will protect your camera from dam-

This manual will show you how to use your camera correctly.  
Please follow the instructions carefully.

## CONTENTS

Names of parts	12
Description of the functions of parts	13
Camera care and cautions	14
Special features	15
Specifications	16
I. Readyng the camera	17
Loading the batteries	17
Display and printing of data	18
Attaching the accessories	19
Loading the film	20
II. Basic procedures	22
Taking automatic-mode (autofocus/programmed auto exposure/automatic flash) pictures	22
Unloading the film	24
III. Advanced techniques	24
Aperture-priority auto exposure	24
Manual exposure	25
Using the built-in flash	26
Using an external flash	28
Exposure compensation	28
Using the focus lock	28
Manual focusing	29
Using the self-timer	29
IV. Extra functions	30
V. A word on the camera's autofocus system	31
Reference data	31

## NAMES OF PARTS

- ① Dial Lock Release
- ② Selecting Dial
- ③ Up/Down Dial
- ④ Exposure Compensation Button
- ⑤ Passive Autofocus Window
- ⑥ Active Autofocus Window (also serves as an AE light receptor)
- ⑦ Shutter Release Button
- ⑧ Self-timer Lamp
- ⑨ Camera Grip
- ⑩ Lens Cap Sensor
- ⑪ Hot-Shoe
- ⑫ Finder Window
- ⑬ Viewfinder Focus Adjusting Dial
- ⑭ Flash Head
- ⑮ Finder Light Intake Window
- ⑯ Sync Socket
- ⑰ Strap Lug
- ⑱ AE light Sensor
- ⑲ Flash Sensor
- ⑳ Active Autofocus Window
- ㉑ Lens
- ㉒ Self-timer Button
- ㉓ Flash Button
- ㉔ Liquid Crystal Display
- ㉕ Film Reminder Slot
- ㉖ Camera back
- ㉗ Film Loading Knob
- ㉘ Mid-roll Wind-up Button
- ㉙ Tripod Socket
- ㉚ Finder Eyepiece
- ㉛ Date Button
- ㉜ AF/M Button
- ㉝ Zoom Lever
- ㉞ Cable Release Socket
- ㉟ Light Button for the liquid Crystal Display
- ㊱ Camera Back Lock

- 37 Spool Loading Knob
- 38 Battery Compartment Cover Screw
- 39 Battery Compartment Cover
- 40 Pressure Plate Changeover Switch
- 41 Film Feed Chamber
- 42 Focal Plane Rail
- 43 Data printing Window
- 44 Film Wind Sensor Roller
- 45 Spool
- 46 Pressure Plate
- 47 Spool Pressure Spring
- 48 Film Sensor
- 49 Spool Shaft Buttons
- 50 Film Take-up Chamber

### Liquid Crystal Display (LCD)

This illustration shows all signs and indicators displayed in the LCD. Usually, only the information needed for each shot is displayed.

- 51 Data Printing Sign
- 52 Exposure Indicator
- 53 Film Speed Sign
- 54 Shutter Speed/Shooting Distance/Exposure Compensation/Film Speed Indicator
- 55 Seconds
- 56 F-number
- 57 Distance Unit Sign(m)
- 58 Battery Sign
- 59 Film Type Indicator
- 60 Manual Focusing Mode Sign (If this sign does not appear, the camera is set for autofocus)
- 61 Flash Sign
- 62 Self-timer Mode Sign
- 63 Exposure Compensation Mode Sign
- 64 Exposure Counter

## DESCRIPTION OF THE FUNCTIONS OF PARTS

### ● Selecting Dial

- (1) OFF: Power off – Set it to OFF when not using the camera.
- (2) P : Programmed auto exposure – For setting exposure (aperture and shutter speed) automatically.
- (3) A : Aperture-priority auto exposure – If you set the aperture, the shutter speed is set automatically. When the built-in flash is used, the shutter speed will not be slower than 1/45 sec.
- (4) As : Slow synchro-aperture priority auto exposure – If you set the aperture, the shutter speed is set automatically. (When the built-in flash is used, the shutter operates for the range from the high speed to 2 second slow shutter speed.)
- (5) M : Manual exposure – You can set your desired aperture and shutter speed.
- (6) ISO : To set the film speed, use this dial and the Up/ Down Dial.

### ● Up/Down Dial

This dial has the following functions:

- (1) Feeding of the film leader when loading film.
- (2) Aperture setting in the aperture-priority auto exposure mode. (Selecting Dial : A, AS)
- (3) Setting of aperture and shutter speed in the manual exposure mode.
- (4) Setting of the film speed. (ISO).
- (5) Selecting the autofocus or manual focusing mode
- (6) Setting of the shooting distance in the manual focusing mode.
- (7) Setting of the exposure compensating value (+/- EV) in the exposure compensation mode.
- (8) Setting of the date and time.

### ● Pressure plate changeover switch (120/220)

For setting the 120 or 220 film

### ● Exposure Compensation Button (■)

- (1) To compensate exposure, use it with the Up/Down Dial.
- (2) To choose a shutter speed for manual exposure, use it with the Up/Down Dial.

● **Data Button (DATA)**

Using this button and the Up/Down Dial, data (date, time, and exposure data) printing is set.

● **AF/M Button**

Using this button with the UP/Down Dial for Setting the shooting distance and autofocus.

● **Self-timer Button (Ⓢ)**

For setting the self-timer mode.

● **Flash Button (Ⓛ)**

For popping up and turning on the flash.

● **Zoom Lever**

For changing focal length toward the tele and wide.

## CAMERA CARE AND CAUTIONS

Your camera is a precision instrument. When handling it, take sufficient care and observe the following instructions.

### 1. Cleaning the camera

- Do not use solvents, such as thinner or alcohol, to clean your camera.
- Make it a habit to clean the camera before and after taking pictures. To clean it, dust off with an air blower and wipe the camera exterior with a soft cloth such as silicon cloth.
- Dust and soil inside the film chamber may damage your film. Take particular care to clean the camera interior.

### 2. Cleaning the lens

- Scratches on the lens surface can reduce its sharpness far more than you would think. If the contrast of your picture seems somehow insufficient and it does not look crisp enough, the possible cause is scratches on the lens surface. Clean the lens carefully in the procedure described below.

- ① Set the Selecting Dial to OFF.
- ② Blow off dust and debris from the lens surface with an air blower.
- ③ Moisten a sheet of lens cleaning paper with a commercially available lens cleaning fluid and wipe the lens gently with it in a circular motion. Always start from the center then gradually move

out to the edges.

- ④ Finally, after all contaminants have been removed, wipe off the remaining lens cleaning fluid with a dry sheet of lens cleaning paper. Again, start from the center in a circular motion then move out to the edges.
- Breathing a mist on the lens surface then wiping it with silicon cloth or other similar material is the worst thing you can do. Never do it because this is one of the main causes of scratches on camera lenses.
- Clean the Autofocus Window and Finder in the same way as described above for the lens. Scratches on the Autofocus Window can cause incorrect focusing.

### 3. Liquid crystal display

- Though the liquid crystal display may sometimes look black at a high temperature around 60 °C, it will return to normal at an ordinary temperature.
- At low temperatures, the response speed of the liquid crystal display tends to become slower. But this is a natural characteristic of the liquid crystal and it does not mean anything wrong.

### 4. Battery note

- Though battery performance will generally be reduced by low temperatures, it will return to normal at an ordinary temperature. If you are shooting in cold weather, be sure to use new batteries and keep spare batteries on hand and, while warming them in a pocket, use these batteries alternately. If the battery power is low, the camera may will not operate at low temperatures.
- If the Battery Sign (⊖) switches to the Battery Low Sign (⊖), you should change the batteries soon. Take spare batteries along with you.
- Never dismantle the batteries, heat, throw into fire, charge or cause them to short circuit.

### 5. The working temperature range

- The working temperature range for this camera is -10°C to +40°C.

## SPECIFICATIONS

- **Type**  
Fully automatic, 6 × 4.5 cm format autofocus zoom camera (corresponding to the bar code system)
- **Picture Size**  
6 × 4.5cm format (actual picture size: 56 × 41.5 mm)
- **Film**  
120 (16 exposures) and 220 (32 exposures) roll film.
- **Lens**  
Super EBC Fujinon 1:4.5 – 6.9 f=55 – 80 mm lens (10 components, 10 elements), equivalent to 34 – 56 mm on 35 mm format, 65 – 42° angle of view, 1.0 m minimum focusing distance, 52 mm filter diameter.
- **Focusing**  
Hybrid (active type and passive type) autofocus system, 1.0 m – ∞ focusing range, switchable to manual focusing mode, provided with focus lock.
- **Finder**  
Illuminating window type bright frame finder, automatic parallax correction, 88% field of view at infinity (∞), 90% at 3 m, 0.4 – 0.58× magnification.
- **Display in the Finder**  
Picture frame (bright frame), autofocus sign, data display: aperture value, correct-exposure sign (⊕), shutter speed, flash activation, shooting distance, distance unit (m). Shutter actuated display.
- **Shutter**  
Electronic, programmed auto-exposure interlens shutter (exposure settings on aperture-priority auto exposure and manual exposure are also possible), provided with buzzer for indicating that the shutter has tripped.
- **Shutter Speed**  
B, 2 sec. - 1/700 sec.
- **Self-timer**  
Electronic self-timer with 10 sec. delay, provided with countdown lamp.

- **Exposure Control**  
Center-weighted light metering (SPD photocell), programmed auto exposure, A, AS: aperture-priority auto exposure, manual exposure, EV 3 - 19 coupling range (ISO 100).
- **Exposure Compensation**  
±3 EV in 1/2-stop increments.
- **Film Speed Setting**  
ISO 25 - 1600 in 1/3-step increments.  
Automatically set with a bar code system film loaded.
- **Flash**  
Built-in, pop-up type flash, automatic control of amount of light, guide number 12 (ISO 100).
- **Film Advance**  
Automatic first-frame positioning (alignment of start mark is not necessary), automatic winding, provided with buzzer for indicating the last frame, film is automatically wound up after the last frame is exposed.
- **Exposure Counter**  
Additive type counter on liquid crystal display, interlocked with 120/220 pressure plate switchover, "E" sign appears after the last frame is exposed.
- **Liquid Crystal Display (LCD)**  
Number of exposures, shutter speed, aperture, film speed, type of film (120 or 220), battery warning sign, flash activation sign, exposure compensation mode sign, self-timer mode sign, manual focusing mode sign, date and time (Year Month Day/Day Hour Minute), shooting distance, total shots indicator.
- **Data Printing**  
Printing outside the picture frames, dates (Year Month Day/Hour Minute), exposure data (exposure mode, aperture, shutter speed, exposure compensating value, AF/MF.)
- **Others**  
Hot-shoe, film reminder slot, cable release socket, sync socket, tripod socket, provision for switching on and off buzzer sound. Lens cap warning.
- **Power Source**  
Two CR123A/DL123A lithium batteries; about 1600 shots can be taken without flash.

## 6. Storage precautions

- In hot weather, do not leave your camera in a closed compartment of your car, or on an ocean beach and in moist places except temporarily for a very short time.
- Keep the camera where it will be safe from moisture, heat, and dust. Be sure to put the lens cap on the lens.
- Do not store it in a wardrobe drawer because the gas of naphthalene or other insecticides can cause damage to the camera and film.

## 7. Film loading and unloading

- Always load and unload film in subdued light.

## SPECIAL FEATURES

- A fully automatic, 6 × 4.5 cm format autofocus zoom camera (Corresponding to the bar code system)

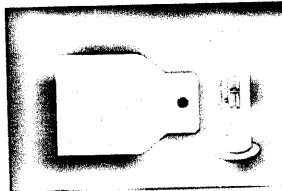
- ① Super EBC Fujinon 1:4.5 f=55 mm ~ 1:6.9 f=90 mm 1.6× zoom lens promises sharp and clear pictures with high image quality from wide to tele.
- ② Use of film with the bar code system eliminates erroneous film settings and prevents erroneous use of film.
  - Automatic film speed (ISO) setting
  - Automatic pressure plate setting (automatic focal plane adjusting, automatic exposure counter interlocking, automatic film type indication on the LCD panel)
- ③ Equipped with the Lens Cap Sensor - Preventing an erroneous exposure with the lens cap on.
- ④ The LCD equipped with an EL back light - Easily checked displays even in the dark
- ⑤ Hybrid autofocus system (passive type with external light (sensing phase contrast) and active type with infrared rays (sensing infrared rays)) backs up the Super EBC Fujinon lens to bring its high performance into full play.

## ● What is a "Bar Code System"?

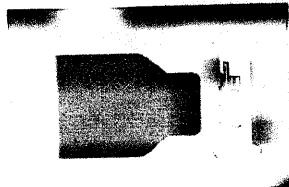
The film speed (ISO), type of the film (120/220), and other data are recorded in a bar code format on the seal which connects the leader paper with the film. The Fujifilm's bar code system allows the camera reading this bar code and setting the film speed and type of the film automatically.

## ● Easy-loading film

This system allows the film to be easily and correctly loaded simply by inserting the leader paper into the slot on the take-up spool. To be more specific, the round opening in the leader paper head is hooked to the claw on the slot of the take-up spool. The leader paper is properly stretched preventing the roll from slackening and the film is loaded completely.



Easy-loading film



Conventional film

- **Dimensions**

161.5 (W) × 108.5 (H) × 73 (D) mm.  
(Dimensions when the lens barrel is retracted)

- **Weight**

885 g (without batteries).

- **Accessories**

Camera soft case, neck strap, lens hood, lens cap, batteries (two).

\* Specifications and performance are subject to change without notice.

## I. READYING THE CAMERA

### LOADING THE BATTERIES

#### 1. Open the battery compartment cover (Fig. 1)

Set the Selecting Dial to OFF and, with a coin, turn the Battery Compartment Cover Screw toward the arrow to pen the Cover.

#### 2. Insert the batteries (Fig. 2)

Insert the batteries in the Battery Compartment with the plus (+) and minus (-) ends as illustrated inside the Cover, then replace the cover and tighten it with a coin.

- Use two 3V CR 123A/DL 123A Lithium batteries.

- The camera will not operate unless the batteries are correctly loaded.

- Change the two batteries at the same time and always use new batteries. Do not mix new and old ones.

#### 3. Check the batteries (Fig. 3, 4)

While pressing in the Dial Lock Release, turn the Selecting Dial from OFF to "P" (or "A" or "As" or "M"). If the Lens moves out into shooting position, the batteries are loaded correctly.

#### 4. Condition of batteries (Fig. 5)

- Indicator lights (Fig. 5-A)

- Indicator lights (Fig. 5-B)

- Indicator flickers (Fig. 5-C)

① The battery capacity is normal.

② The battery capacity is low. Replace the batteries with new ones.

③ Since the battery capacity is low, the shutter lock is applied. Replace the batteries with new ones.

- A pair of new batteries will provide power for taking about 1600 shots without flash, and about 450 shots when half of the pictures are taken with flash (as tested according to Fujifilm's battery testing procedure).

## DISPLAY AND PRINTING OF DATA

- This camera incorporates a data printing unit which allows you to print the date, time, and exposure data outside the picture frames on your film.

### 1. Changing the data format

Data Format	Display on LCD (Example)	Printing (Example)
<pre>           graph TD             A[Printing off] --&gt; B[Year Month Day*1]             B --&gt; C[Day Hour Minute]             C --&gt; D[Exposure Data]             D --&gt; E[Year Month Day/Exposure Data]           </pre>	<pre>           ---           '98 4 1           11:35           TV 45 56           Shutter speed ← F-number           '98 4 1 TV 45 56           ← Blinks alternately →           </pre>	<pre>           '98 4 1           1 15:35           Program mode           Displayed when the built-in flash fires.           P 55mm F5.6 1/45 +0.5 EV AF S           Shooting focal length.   F-number   Shutter speed   Exposure Compensation   AF/MF           '98 4 1 P 55mm F5.6 1/45 +0.5 EV AF S           </pre>

After changing the batteries, the data format is initially set to " - - - - " (printing off). Each time you press in the Data Button, the arrangement of data will change as shown above. If your desired format appears, stop operating it.

The display of the data in the format which you have set will turn on for five seconds after you remove your finger from the Button, then turn off. The [DATA] Sign in the LCD will remain on to tell you that the camera has been set to the data printing mode.

- \* The "Year Month Day/Exposure Data" will blink alternately because all of these data cannot be displayed in the LCD at the same time.
- \* When the exposure compensation has been set, the compensated values of aperture and shutter speed will be displayed.

- \* When the shutter speed is set to "Bulb", "bul" will be displayed on the LCD, and "BULB" will be printed as the exposure data.
- \* 1: Changing the data format; Data mode column. Year Month Day can be changed in the following sequence whenever the Selecting Dial is set from OFF to ISO with the Zoom Lever pressed downward (Wide angle side). (Fig. 6)

► Month Day Year → Day Month Year → Year Month Day

When the date is set once under a selected mode, the mode will last until it is changed again.

## 2. Data printing example (Fig. 7)

Data under the set mode (date and exposure data) are indicated outside the picture frames on your film. The printed exposure data are exposure mode, focal length, aperture, shutter speed, exposure compensation value, focusing mode (automatic or manual) and flash used or not.

\* When the flash fired, "S" will be printed. When the flash is turned on under the P mode but the light is so bright that the flash is not required, "S" will not be printed.

## 3. Set the date (Fig. 8, 9)

- ① Pressing in the Dial Lock Release;
- ② As the Selecting Dial to "P" (or "A" or "As" or "M").
- ③ Pressing in the Data Button, press in the AF/M Button.
- ④ The Year number will blink. When the Year number has started blinking, you may leave your finger from the Data Button.
- ⑤ Set the blinking Year number correctly with the Up/Down Dial.
- ⑥ Press in the AF/M Button to complete the Year setting. The next number (Month) will then blink. Set the number correctly as described in ⑤ above.
- ⑦ As the AF/M Button is pressed in, set numbers will be shifted from Month to Day, from Day to Hour, and from Hour to Minute. Set the numbers correctly with the Up/Down Dial.

## 4. Set the time (Fig. 10)

- ⑧ Set the correct Minute as described above, and press in the AF/M Button. Second will be zero-set, the film speed (ISO) will be displayed, and thus, time setting ends.
- \* The correct date will be displayed up to the year 2030.  
\* When the batteries are replaced with new ones, the set data are erased. Be sure to reset the data.

## ATTACHING THE ACCESSORIES

### 1. Attach the neck strap (Fig. 11, 12)

- Anti-loosening Ring (Fig. 11-A)
- Buckle (Fig. 11-B)

Your camera has three Strap Lugs, and you can attach the neck

strap either vertically or horizontally.

- ① Pass both ends of the strap through the Strap Lugs.
  - ② Adjust the strap length properly with the Buckle.
- When you pass the strap ends through the Anti-loosening Rings, slide the Anti-loosening Rings. The strap ends will pass through the them more easily.

### 2. Put on the lens cap (Fig. 13)

Take two buttons on the lens cap with your fingers to put it on or off.

To prevent accumulating dust and other foreign matters on the lens glass, put the lens cap on as soon as you are through taking pictures. To clean the lens, refer to "Cleaning the lens" on page 14.

### 3. Put on the lens hood and filter (Fig. 14)

- Indicator (Fig. 14-A)

#### [Lens Hood - Bayonet type]

Place the indicator on the lens hood upward as shown in the figure, put the hood into the front of the lens barrel and turn it to the right till it is locked.

- The lens hood has been designed especially for your camera. Be sure not to use the lens hood other than that comes with your camera. If you use other hoods, Fujifilm cannot guarantee correct autofocus because light may fall off along the picture edges or the autofocus beam may be blocked.

#### [Filter]

Use commercially available 52 mm diameter filters. The filter is mounted by screwing it into the front of the lens barrel.

- Do not put on two or more filters. Fujifilm cannot guarantee correct autofocus because light may fall off along the picture edges.
- When taking pictures by using filters with exposure factors, be sure to compensate exposures accordingly with the exposure factors.

### 4. Use the soft case (Fig. 15)

Always try to keep your camera in the Soft Case when carrying it about or storing. Such a habit will protect your camera from dam-

aging and dust. You can keep your camera in the Soft Case with the lens hood attached to the lens barrel.

## LOADING THE FILM

### 1. Opening and closing the camera back (Fig. 16)

To open the Camera Back, raise the Camera Back Lock and turn it toward the arrow (counterclockwise). To close the Camera Back, press it gently against the body till you hear the snapping sound. Then, turn down the Camera Back Lock to the original position.

\* For the protection of the lens, recommend the Selecting Dial be set to OFF when opening or closing the Camera Back and when loading the film.

### 2. Setting the pressure plate (Fig. 17)

No pressure plate setting is required when a film with the bar code system is used. The camera automatically sets the pressure plate according to the film loaded. When a conventional film (without bar code) is used, set the pressure plate. Open the Camera Back and press in the Pressure Plate Changeover Switch so that the LCD indicates the type of film loaded. The pressure plate will be set automatically and accordingly with the loaded film after advancing the film.

### 3. Type of film and number of exposures

- 120 roll film: 16 exposures
- 220 roll film: 32 exposures
- The exposure counter is interlocked with the pressure plate changeover system, and when the pressure plate is set, the exposure counter is also changed over accordingly with the type of film loaded.
- While 120 roll film is attached to an opaque backing paper over its entire length, such paper is used only on both ends of 220 roll film. The thickness of the backing paper causes a shift in the position of the focal plane, and the pressure plate adjusts for this difference while keeping the film flat on the focal plane. Therefore, check the type of film loaded displayed on the LCD to make sure that the Pressure Plate is set correctly for the film loaded.

\* For the protection of the lens, it is recommended that the Selecting Dial be in the off position when loading film.

Pressure Plate Setting	120	220
Type of Film Loaded	220	120
LCD Indication	"120" lights	"220" lights
Exposure Counter	After exposing the 15th frame, the buzzer sounds, and the film is wound up after exposing the 16th frame. Then, "E" will be displayed.	Operation may vary depending on the film type used. Most films are wound up after exposing the 16th frame, and "E" will be displayed.
Result of Exposure Counter	Accurate focusing may not be made when the lens is at or near the fully opened position.	

- When you find, after advancing the film, that the pressure plate has not been set correctly, correct it by the following method:
  - ① Set the Selecting Dial to "OFF".
  - ② Pressing in the Data Button, set the Selecting Dial from "OFF" to "ISO".
  - ③ Check the LCD to insure that the Battery Sign and "120" or "220" have been indicated.
  - ④ Keep pressing in the Data Button, turn the Up/Down Dial to the desired type of film.  
Turned clockwise: "120"  
Turned counterclockwise: "220"
  - ⑤ Leave your finger from the Data Button to end the setting.

### 4. Press in the spool shaft buttons (Fig. 18)

Press in the Spool Shaft Buttons on both sides. The Spool (Film) Loading Knobs will pop out.

\* The Take-up Spool and roll film can be loaded easier by fitting in the top side first, then pressing in the bottom side.

**5. Replace the empty spool (Fig. 19)**

Take out the empty spool, fit it into the Take-up Chamber (on the right side), then press in the Take-up Spool Knob.

\* The empty spool is set in the Take-up Chamber, at the time of purchase.

**6. Insert the film (Fig. 20)**

Insert the film in the Film Chamber (on the left side), then press in the Film Loading Knob till you hear the snapping sound and it draws back completely.

● Confirm that the Film Loading Knob has drawn back and been fixed completely. If not, slackened film roll and inaccurate focusing may result.

**7. Pull out the leader paper (Fig. 21)**

① Pull out the film leader paper and pass it along the film channel.

② Insert the tip into the slot of the take-up spool. The round opening in the leader paper head will be hooked to the claw on the slot of the take-up spool. (Insert the tip into the slot of take-up spool in the same manner also when the used film and spool are not of an easy-loading type.)

● Turn the Up/Down Dial to the arrow direction to adjust the spool slot position so it can be readily seen. The spool turns 90 degrees as the Up/Down Dial is turned, and the position can be adjusted easily.

**8. Wind the leader paper (Fig. 22)**

● Line up the start mark with this pin. (Fig. 22-A)

Wind the leader paper around the take-up spool by turning the Up/Down Dial toward the arrow. When you are using 120 roll film, wind it until the start mark appears in the left side. Do not wind it any more. When you are using 220 roll film, wind it in by about 3 to 5 turns (about 15 cm) around the spool.

● To prevent the roll from slackening, press down the leader paper at the left side, and applying tension, wind the leader paper securely around the Take-up Spool.

● If you wind the film by only 1 to 2 turns around the Spool

and close the Camera Back, the roll may slacken. Be sure to wind the film by 3 to 5 turns around the spool.

\* Exact start mark positioning is not required because the film tip is detected by the Film Sensor. Be careful, however, not to wind it in too much until the start mark comes to the right side of the picture frame center because the first-frame will not be positioned correctly causing it to be partially exposed.

**9. Set the film speed (ISO) (Fig. 23)**

① While pressing in the Dial Lock Release, set the Selecting Dial to "ISO". "ISO" will then blink on the LCD, indicating that the camera is under ISO setting mode.

\* Automatic ISO setting with a bar code system film used

② Turn the Up/Down Dial clockwise to set it to "Auto".

\* Manual ISO setting with a film without bar code used

③ Turn the Up/Down Dial to set it to a desired number.

When turned clockwise : UP

When turned counterclockwise: DOWN

**10. Set the film to the first frame (Fig. 24)**

① Close the Camera Back.

② While pressing down the Dial Lock Release,

③ Set the Selecting Dial to "P", "A", "As" or "M". The film will then automatically advance to the first frame position, and the Lens will move out into shooting position.

④ When the Selecting Dial has already been set to "P", "A", "As" or "M", the film will automatically advance to the first frame position as the Shutter Release Button is pressed down.

⑤ When the film is set to the first frame, the exposure counter displays "1". Also displayed are ISO [Number] and set pressure plate setting number 120 or 220.

\* When a film is not loaded correctly (slackened), the validity date has been expired, or improperly stored film is used, the camera may not read the film data correctly.

\* When the Up/Down Dial is set to "Auto" and LCD displays "---", the camera is not reading the bar code of the film correctly or film used has no bar code. In this case, the shutter is locked and the camera does not work. Set ISO number and changeover the pres-

sure plate correctly.

- \* Recommend the top cover of the film box be cut out and inserted in the Film Reminder Slot so that you won't forget which film you are using.

## II. BASIC PROCEDURES

### TAKING AUTOMATIC-MODE (AUTOFOCUS/ PROGRAMMED AUTO EXPOSURE/ AUTOMATIC FLASH) PICTURES

- If you set the camera to the automatic modes, you can take pictures very easily.

#### 1. Set the camera to the programmed auto exposure mode (Fig. 25)

While pressing in the Dial Lock Release, set the Selecting Dial to "P" The camera is set to the programmed auto exposure mode, in which the aperture and shutter speed are automatically set according to the brightness of the subject.

- The programmed exposure diagram on page 31 shows the coupling ranges of aperture and shutter speed in the programmed auto exposure mode.
- When taking pictures without flash in the programmed auto exposure mode, caution is required because camera shake may to occur with a shutter speed lower than 1/45 sec.

#### 2. Check the autofocus (Fig. 26)

Make sure that the "MF" is not displayed in the LCD. If it is displayed, pressing in the AF/M Button, turn the Up/Down Dial counterclockwise to place the camera under the autofocus mode. The "MF" will disappear as you leave your finger from the AF/M Button.

- When the "MF" is not displayed, it denotes the camera is under the autofocus mode.
- When the "MF" is displayed, it denotes the camera is under manual focus mode. (Refer to page 29.)

#### 3. Ready the flash (Fig. 27)

Press in the Flash Button (⚡) and let the Flash Head pop up. When

the camera is placed under the programmed auto exposure mode (P mode), the Flash will not fire in bright light but it will automatically fire in dim light.

- \* It will automatically fire in brightness of EV12 or equivalent (at F5.6, 1/90 sec. with ISO 100 film loaded).
- \* For details on flash photography, refer to page 26.

#### 4. Display in the finder (The figure below shows all markings displayed in the finder) (Fig. 28)

- ① Field-of-view frame (for distant objects) (Fig. 28-A)
- ② Field-of-view frame (for near objects) (Fig. 28-B)
- ③ Field-of-view frame (fixed) (Fig. 28-C)  
The area seen inside the frame ① or ③ will be taken in your picture.  
The field-of-view frame ① moves to the position of ②, and the parallax is compensated automatically.
- ④ AF (autofocus) frame (Fig. 28-D)  
Aim at the desired object by positioning it within this AF frame. The Lens will focus on the object aimed within this frame.
- ⑤ Shutter actuated sign (Fig. 28-E)
- ⑥ Aperture value (F-number) (Fig. 28-F)  
Blinks when it is not suited for correct exposure.
- ⑦ Over or under exposure sign (Fig. 28-G)  
Under "P", "A" or "As" mode: This sign is not displayed when the exposure is correct.  
Under "M" mode: ⚡ lights when the exposure is correct.  
▲ lights in case of an overexposure.  
▼ lights in case of an underexposure.  
When ▲ ▼ appear under "P", "A" or "As" mode, it denotes the system is outside the exposure interlocking range.
- ⑧ Shutter speed (Fig. 28-H)  
The sign "BUL" will light when the shutter speed is slower than 0.7 sec. The sign "BUL" will appear during bulb exposure.
- ⑨ Exposure compensation set sign (⊞) (Fig. 28-I)  
This sign appears when exposure compensation is set.
- ⑩ Flash sign (⚡) (Fig. 28-J)  
When this sign appears, the flash will fire. When charging the flash system, this sign will blink.

**④ Distance (Fig. 28-K)**

"■" lights in response to the distance measured by the autofocus system. When two signs light, the measured distance is in the middle of two signs. "■" blinks when distance is set under the manual focus mode.

- \* The distances displayed in the finder are hints for autofocus distance measuring.

**5. Adjust diopter of the finder (Fig. 29)**

Looking at an AF frame through the finder, turn the diopter adjust dial properly so that the object can be seen clearly.

When you are far-sighted, turn the dial clockwise (toward "+" side), or when you are short-sighted, turn it counterclockwise (toward "-" side).

The diopter adjustable range is -3 to +1D.

**6. Hold the camera (Fig. 30, 31)**

- Taking vertical-position pictures (Fig. 30)
- Taking horizontal-position pictures (Fig. 31)

Camera shake is a typical cause of harming sharpness of pictures taken.

Hold the camera still with both hands with your arms tightly attached to your body, and squeeze the Shutter Release Button gently down.

- Be sure to keep your fingers and neck strap away from the Flash Sensor, AE Light Sensor and Autofocus Windows. If these parts are blocked, exposures and focusing cannot be made correctly resulting a poor quality picture.

When you are taking horizontal-position pictures, position the Camera Grip side down. When the built-in flash fires, shade of the object is likely to appear in the back.

- When taking pictures under 1/45 sec. or slower shutter speed, mount the camera on a tripod to prevent camera shake.

**7. Lens cap warning (Fig. 32)**

When the Shutter Release Button is pressed half way down with the lens cap put on the lens, the field-of-view frame in the viewfinder blinks to warn you. Take out the lens cap before taking pictures.

- \* The Lens Cap Sensor located in the lens barrel measures outside brightness and generates signals. For this reason, when the brightness is darker than EV6 ISO 100 (F5.6, 1/2), no warning will be made.

- \* The lens cap warning can be turned on or off. (Refer to page 30.)

**8. Zoom the lens (Fig. 33)**

When zooming the lens to the tele side (spotting an object in large size), slide the Zoom Lever up.

When zooming the lens to the wide side (taking a picture in wide range), slide the Zoom Lever down.

When zooming the lens, the lens stops at positions for 55 mm, 65 mm, 75 mm and 90 mm focal lengths.

**9. Compose your picture (Fig. 34)**

- AE light measuring area (Fig. 34-A)
- AF ranging area (Fig. 34-B)

① Aim at the desired object within the AF mark "[ ]" (AF ranging area).

② Press the Shutter Release Button halfway down, hold it there and check the display in the Finder.

- When the object you aim at is out of the AF mark, shoot using focus lock. For further information on focus lock, refer to Page 28.

**10. Check the exposure (Fig. 35)**

- Blinking (Fig. 35-A)

① When you see neither the Overexposure (▲) nor the Underexposure (▼) Sign in the Finder, you will obtain correct exposure. (Except for the manual mode)

② When the Underexposure Sign (▼) lights and both the F-number and shutter speed blink, the camera can not set correct exposure within its coupling range, and your picture will be underexposed.

③ When the Overexposure Sign (▲) lights and both the F-number and shutter speed blink, the camera cannot set correct exposure within its coupling range, and your picture will be over-

exposed.

- ④ When the Flash Sign (⚡) turns on, it tells you that the Flash will fire automatically.

### 11. Check the shooting distance (Fig. 36, 37)

#### • Blinking (Fig. 36-A, 37-A)

- ① When the distance indicator "M" lights, the camera has completed focusing and set the correct distance.
- ② When the 1m distance indicator "1" blinks, you are too close to your object. Move back 1m or more from the object.
- When the displayed distance on autofocus differs remarkably from that estimated with your eyes, the cause may be that the Autofocus Spot is off your object. Focus again correctly by aiming the Autofocus Spot at your object.
- ③ When ∞ (infinity) blinks, it tells you that your camera cannot focus correctly. Use manual focusing or Focus Lock. (For details, refer to Page 28.)
- When the Shutter Release Button is depressed with the distance indicator ∞ (infinity) blinked, the Lens will focus on infinity.
- When the distance indicator blinks all the time, your camera is under the MF (manual focus) mode. Set it to the AF mode.

### 12. Trip the shutter (Fig. 38)

Press the Shutter Release Button halfway down and check the composition, distance and exposure. When all right, press the Shutter Release Button gently all the way down. When the shutter trips, the shutter trip indicator in the finder (upper left portion) lights, and an electronic buzzer "beep" sounds.

- \* When using the cable release, this halfway-down mode is not possible. Be careful to make one positive shutter pressing to operate the distance, exposure and shutter tripping.

### 13. When the last frame is reached (Fig. 39)

If the film is positioned for the last shot, an electronic buzzer will sound six times to tell you that the film has reached the last frame.

- \* If the sound of the electronic buzzer is worrisome, you can switch it off. For details, refer to "Extra functions" on page 30.

## UNLOADING THE FILM

### 1. Exposing the last frame and unloading the film (Fig. 40)

After exposing the last frame, the film will automatically wind itself up to the very end and the letter "E" will appear in the LCD. Make sure the "E" Sign appears in the LCD, then open the Camera Back and take out the exposed film. To prevent the film from loosening, seal it tightly with the End Seal.

### 2. Unloading the film in mid-roll (Fig. 41)

Press in the Mid-roll Wind-up Button on the camera bottom. The film will wind itself up to the very end then stop. When winding is completed, the "E" Sign will appear in the LCD.

## III. ADVANCED TECHNIQUES

### APERTURE-PRIORITY AUTO EXPOSURE

This technique is used when you want to give perspective to the taken pictures by opening up the aperture, or to take sharp pictures covering short distance to long distance by stopping down the aperture.

For aperture-priority auto exposure, there are two modes; mode A and mode As. When the built-in flash is not used, the camera functions in the same manner under both modes A and As.

When the built-in flash is used, it fires normally.

However;

Under mode A: The shutter speed will not be slower than 1/45 sec. Under mode As: Depending on the light measured by your camera, the shutter speed is controlled up to 2 sec. This mode is used when taking nighttime scenes or portrait with the slow synchro-aperture priority technique. Recommend the camera be mounted on a tripod because shutter speed is so slow that the camera shake is likely to occur.

### 1. Setting the selecting dial (Fig. 42)

While pressing in the Dial Lock Release, set the Selecting Dial to "A" or "As".

## 2. Set the aperture (Fig. 43)

Turn the Up/Down Dial. The aperture indicated on the LCD will change. The aperture will open up by turning the Dial clockwise, and is stopped down by turning counterclockwise.

- The aperture will be displayed in 1/2-stop increments.

55 mm	F4.5 ~ F22
65 mm	F5.2 ~ F27
75 mm	F6.2 ~ F32
90 mm	F6.9 ~ F38

- When the aperture is set to F6.9 at tele side 90 mm and the Zoom Lever is slid down (toward the wide side), the aperture becomes F6.7 at 75 mm, 65 mm and 55 mm. When taking pictures with the aperture fully opened, fully open it again after deciding the zoom position.
- When the aperture is set to F4.5 at wide side 55 mm and the focal length is changed, the aperture is set to the full open F-value suited to the set focal length automatically.

## 3. Press the Shutter Release Button about halfway down (Fig. 44)

Aim your subject and press the Shutter Release Button about halfway down. The aperture you have set and the shutter speed suited for it will be displayed in the Finder and LCD. If you change the aperture, the shutter speed will change automatically. The upper limit of the shutter speed that can be set differs with the aperture as shown below.

## 4. Check the display in the finder (Fig. 45)

Press the Shutter Release Button halfway down.

- ① When neither the Overexposure Sign (▲) nor the Underexposure Sign (▼) lights, you will obtain correct exposure.

- ② When the shutter speed blinks and the Overexposure Sign (▲) lights, the correct shutter speed suited for the aperture you have set is not within the camera's coupling range. In this case, stop down the aperture.
  - ③ When the shutter speed blinks and the Underexposure Sign (▼) lights, the aperture is stopped down too much and the aperture you have set is not within the camera's coupling range. Open up the aperture or set the camera to the flash picture mode.
- For taking flash pictures, refer to Page 26.
  - In case of incorrect exposure in ② or ③ above, the shutter speed displayed on the LCD will also blink.

## MANUAL EXPOSURE

### 1. Set the selecting dial to "M" (Fig. 46)

When the Selecting Dial is set to M, while pressing down the Dial Lock Release, the "TV" sign will appear in the LCD to inform you that the camera has been set to the manual exposure mode.

- If you want intentional over or underexposure to take high-key or low-key pictures, use manual exposure.
- This mode can also be used to set exposure for backlighted subjects or other subjects for which correct exposure cannot be obtained in the "P" or "A" mode.

### 2. Set the shutter speed (Fig. 47)

While pressing in the Exposure Compensation Button set the shutter speed with the Up/Down Dial. When the Exposure Compensation Button is depressed, the "TV" Sign will blink.

- If the camera is set to the manual exposure mode, the Exposure Compensation Button can be used for setting the shutter speed, but not for exposure compensation.

### 3. Set the aperture (Fig. 48)

Set the aperture by turning the Up/Down Dial.

- If the shutter speed is set for bulb exposure, the "bul" Sign will appear both in the Finder and LCD. During bulb exposure, no battery power is consumed so you need not worry that the batteries may run out during a long exposure.

- At bulb exposure, the shutter remains open while the shutter button is held pressed.
- \* Under the Manual mode, the exposure compensating functions do not work.

#### 4. Adjust the shutter speed and aperture (Fig. 49)

- Correct-exposure Sign (Fig. 49-A)
- Overexposure Sign (Fig. 49-B)
- Underexposure Sign (Fig. 49-C)

Press the Shutter Release about halfway down. If the Correct-exposure Sign (⊕) appears in the Finder, the exposure is correct. If the Over (▲) or Underexposure (▼) Sign appears, adjust the aperture or shutter speed so that (⊕) Sign turns on.

- If you want intentional over or underexposure, take pictures with the Over (▲) or Underexposure (▼) Sign displayed in the Finder.

### USING THE BUILT-IN FLASH

#### 1. Ready the flash (Fig. 50)

- ① Pop up the Flash Head by pressing the Flash Button.
  - ② As soon as the Flash Sign (⚡) in the LCD stops blinking and glows, the flash is ready to fire.
- The Flash Sign (⚡) will blink while the flash is charging. While it blinks, the camera's operating functions such as releasing the shutter will not work.
  - The table shows the minimum exposure (allowable aperture) depending on the ISO value, due to the limitation of flash control capabilities.

ISO	50	100	200	400
Minimum exposure	8	11	16	22

#### 2. Exposure control with the built-in flash (Fig. 51)

- Flash sensor (Fig. 51-A)

When taking flash pictures, the exposures are controlled under the manner of an automatic flash. To be more specific, the intensity of the light reflected by the object is measured and its amount of light is automatically adjusted in accordance with the set aper-

ture. The flash sensor which receives the light reflected from the object measures the amount of light in the center of the picture frame.

- When your camera is under "A", "As" or "M" mode and flash is tuned on, the flash will always fire.  
You can use it effectively as fill-in light when shooting your object in the shade of a tree or for obtaining a catch-light effect on portraits.

		Flash Pop-Up	Aperture	Shutter Speed
Exposure Mode	Programmed AE	No flash firing	Automatic control	Automatic control
		Automatic firing in low light	Automatic control	Automatic control *1
	Aperture-priority AE "A"	Always fires	Set aperture	Automatic control *1
	Aperture-priority AE "As"			Automatic control
	Manual exposure "M"		Set aperture	Set shutter speed

\*1: To avoid poor picture quality due to camera shake, the shutter speed will not be set to slower than 1/45 sec.

- ① Under programmed AE "P" mode: The flash will fire automatically in low light. (Refer to Programmed Exposure Diagram in Page 31.)
  - ② Under aperture-priority AE "A" mode: The flash will always fire. The amount of the flash light will be controlled in accordance with the set aperture, and the shutter speed will change in response to brightness of the object.
  - ③ Under aperture-priority AE "As" mode: The flash will always fire. The amount of the flash light will be controlled in accordance with the set aperture, and the shutter speed will change in response to brightness of the object. The shutter speed will be quite slow in a dark place. Be careful to avoid camera shake and avoid taking moving objects.
  - ④ Under manual exposure "M" mode: The flash will always fire and the flash will adjust its amount of light according to the set aperture. The shutter will trip at the set shutter speed.
- Light control cannot be compensated with the flash light.

#### 4. Control range

Film speed (ISO)	50	100	160	200	400	800
Guide number	8.5	12	15	17	24	34
Farthest flash distance (m)	W1.9 T1.2	W2.7 T1.7	W3.3 T2.2	W3.7 T2.4	W5.3 T3.5	W7.5 T4.9
Nearest flash distance (m)	1.0					

When a film of ISO 25 is used, the guide number will be 6, and the flash light will be insufficient at the tele side. For this reason, use of the built-in flash is not recommended.

The guide number of the built-in flash (with the maximum amount of light) is 12 at ISO 100. The guide number will increase by 1.4 times if the film speed (ISO) becomes double, and double if the film speed (ISO) increases four times.

- The farthest flash distance is calculated by dividing the guide number by the lens F-number at full aperture (W: 4.5, T: 6.9 in case of your camera).

$$\text{Distance} = \frac{\text{Guide number}}{\text{F-number}}$$

- When your camera is set to the aperture-priority AE (mode "A"), calculate the maximum flash distance with the set aperture.
- Since negative films have a wider exposure latitude, the flash ranges are longer than those in the above table.

## USING AN EXTERNAL FLASH

### 1. Mount the flash on the hot-shoe (Fig. 52)

Mount a commercially available hot-shoe type external flash such as Strobe GA (Fujifilm optional attachment) on the Hot-Shoe of the camera.

- Do not use flashes designed for cameras of other makers that have a signal pin because mounting and dismounting may become impossible.
- When an external flash is used under "P", "A" or "As" mode in a dark place, the camera will select a slow shutter speed resulting blurred pictures. Recommend your camera be used under the "M" mode.
- \* When an external flash is used, the shutter limiter (which operates under "P" or "A" mode) does not work.
- \* Do not use both the built-in flash and external flash together. The flash light will not be controlled correctly.

### 2. Flash light distribution characteristics (Fig. 53)

- Light fall-out (Fig. 53-A)
- Flash light covering area (When the covering area differs depending on vertical or horizontal angle) (Fig. 53-B)
- Covering area for 6x4.5cm version (Fig. 53-C)
- Covering area of Strobe GA (Fig. 53-D)

In the case of an external flash with different vertical and horizontal covering angles (light distributing characteristics), the flash covering area and the direction of an image plane may not coincide. To solve this problem (light fall-out), recommend use of Strobe GA (optional attachment).

Strobe GA has A2 modes.

When ISO 100 film is used and the aperture is set to F8, you can take pictures under the automatic exposure mode.

## EXPOSURE COMPENSATION

### 1. Set the exposure compensating value (Fig. 54)

If you want to take high-key or low-key pictures, use exposure compensation in the programmed auto exposure or aperture-priority auto exposure mode.

- ① While pressing in the Exposure Compensation Button (+/-),
- ② turn the Up/Down Dial.
- ③ The exposure compensating value will be displayed in the LCD in 0.5 EV-step increments.

The compensating range is  $\pm 3$  EV.

### 2. Display of the exposure compensating value (Fig. 55)

When you leave your finger away from the Exposure Compensation Button (+/-) after compensating the exposure, only the "☐" sign will be displayed to tell you that the camera is set for exposure compensation.

Now, press in the Shutter Release Button halfway down. The compensated values of aperture and shutter speed will be displayed. When the compensated exposure value is set, "☐" sign will light also in the finder, informing you that the exposure compensation has been set.

\* It should be noted that the set exposure compensation will be cancelled if the Selecting Dial is set to "OFF".

## USING THE FOCUS LOCK

### 1. A word on the auto-focus lock (Fig. 56)

If the Autofocus Spot is off your object, the Lens will not focus on it. In such a case, move the camera slightly, aim the Autofocus Spot at your object to focus on it, then recompose your picture by moving the camera back to its original position. This method is called "Auto-Focus Lock".

### 2. Aim your object and press the Shutter Release Button halfway down (Fig. 57)

Aim the Autofocus Spot at your main object, and press the Shutter Release Button halfway down to lock the auto-focus.

### 3. Compose your picture and trip the shutter (Fig. 58)

With the Shutter Release Button pressed halfway down, compose your picture and trip the shutter by gently pressing the Shutter Release Button all the way down.

\* When the camera is set to automatic exposure (AE) (programmed or aperture-priority automatic exposure mode), the exposure will be determined for the picture you composed with the Shutter Release Button pressed halfway down (focus locked).

## MANUAL FOCUSING

### 1. Set the manual focusing mode (Fig. 59, 60)

Press in the AF/M Button. The "MF" Sign will blink in the LCD to tell you that the camera is set to the manual focusing mode.

Keep pressing in the AF/M Button, turn the Up/Down Dial clockwise. Distances will be displayed in order of Inf, 20m, .....1.0m (from far distance to close-up distance).

When distance you desire to set is displayed, leave your finger away from the AF/M Button. The displayed distance will go out and MF Sign will light to tell you that your camera has been set to the manual focus mode.

To return the camera to the autofocus mode, keep pressing in the AF/M Button, turn the Up/Down Dial counterclockwise, and leave your finger away from the AF/M Button when the camera is placed in the AF mode. The MF Sign will go out to tell you that the camera has been set to the AF mode.

\* Under the manual focus mode, the distance mark "■" blinks in the finder.

### 2. Effective uses of the manual focusing mode

- ① If you want to have another person take a picture of yourself  
Set the shooting distance beforehand, hand over the camera to another person and ask him (or her) to depress the Shutter Release Button. You need not explain him (or her) how to aim the subject with the Autofocus Spot.
- ② If you want to take a moving object by pan focus  
If you have set the shooting distance in advance by using the manual focusing mode, the time lag caused by a lens drive on

autofocus is eliminated. With the aperture stopped down (to F8 - F11), the lens will exhibit its pan focus effect to enable you to take quick shots.

- ③ If you want to minimize the time lag on shutter operation  
All-automatic cameras require some time for the distance measurement and lens drive. If you set the camera in the following manner, the time lag from the moment you depress the Shutter Release Button to the moment the shutter trips will be minimized to let you take pictures successively.
    - i) Depending on the subject, set the distance by manual focusing.
    - ii) Press the Shutter Release Button about halfway down and move the lens to the set distance in advance.
- Distances set under the manual focus mode

Indications in meter	INF	20 m	10 m	7.0 m	5.0 m	4.0 m	3.0 m
Indications in foot	INF		30		15		10

2.5 m	2.0 m	1.7 m	1.5 m	1.3 m	1.2 m	1.1 m	1.0 m
8	7	6	5		4	3.5	

For changeover across the meter and foot indications, refer to Page 30.

## USING THE SELF-TIMER

### 1. Set the self-timer mode (Fig. 61)

Press in the Self-timer Button (⊙). The Self-timer Mode Sign (⊙) will be indicated on the LCD and the camera is set under self-timer mode.

\* After taking a picture with the Self-timer, the self-timer mode will be switched off. To take a picture with the Self-timer again, press in the Self-timer Button again.

### 2. Start the self-timer (Fig. 62)

Press in the Shutter Release Button. The Self-timer Lamp will light and the Self-timer will start. The Lamp will glow for seven seconds, blink for three seconds, and then, the shutter will trip to take your picture.

- \* Under the self-timer mode, the autofocus and auto-exposure systems of the camera will operate as soon as the Shutter Release Button is depressed. Depending on the object conditions, use manual focusing and manual exposure for compensating for autofocus, intensifying or reducing the object contrast, etc.

#### IV. EXTRA FUNCTIONS

##### 1. External changeover of the pressure plate (Fig. 63)

The pressure plate setting can be changed after loading the film. Set the Select Dial to "ISO", and turn the Up/Down Dial with the Data Button depressed. Type of film (120, 220) display will change on the LCD.

When the Up/Down Dial is turned counterclockwise: 220

When the Up/Down Dial is turned clockwise : 120

- \* When the loaded film is a bar code system film and pressure plate has been automatically set, this function does not work.
- \* This function changes when advancing the film. For this reason, when resetting after the automatic first frame setting, take picture after exposing one extra frame.

##### 2. Switchover of the distance unit (Fig. 64)

The distance unit can be switched over.

- Distance unit in meters (Fig. 64-A)
- Distance unit in feet (Fig. 64-B)

Your camera is Factory-set to display the distances in meters for manual focusing and the letter "m" will be displayed beside the distance number in the LCD. Depressing the AF/M Button, set the Selecting Dial from OFF to ISO. The LCD indication will be changed over from meter to feet, and "Ft" sign will appear on the LCD for five seconds. (When "feet" is set, distance unit (ft) will not be indicated beside the distance number on the LCD.)

- \* In the Finder, distances are displayed in meters only. Even if the "feet" is set, the meter indications will not change to feet.

##### 3. Switching off the buzzer (Fig. 65)

If you feel the buzzer sound worrisome, you can switch it off.

- Buzzer on (Fig. 65-A)

- Buzzer off (Fig. 65-B)

An electronic "beep" which sounds when the shutter tripped, or a repeated "beep, beep, beep....." which tells you that the film has reached the last frame can be switched off.

While pressing in the Self-timer Button, turn the Selecting Dial from OFF to "ISO". The "OFF b" Sign will be displayed in the LCD for five seconds and the buzzer will turn off.

To reset it to "ON", repeat the same procedure. The LCD will show "ON b" for five seconds to tell you that the buzzer has been switched on again.

##### 4. Total shots indicator (Fig. 66)

Use it as a guide for regular maintenance.

- Indicates 3,000th shots (Fig. 66-A)
- Always shows "00" (Fig. 66-B)

Press in the Exposure Compensation Button (+/-) and turn the Selecting Dial from OFF to "ISO". While pressing in the Button, the Total Shots Indicator in the LCD will show you the total number of shots that have been taken. It will count the number in units of 100. Use this function as a guide for overhauling or regular maintenance.

- Though new, some units will show that they have been factory-tested up to about 200 shots.

##### 5. Turn off the lens cap sensor (Fig. 67)

When the Lens Cap Sensor is not required, the warning can be turned off.

Slide the Zoom Lever up (Telephoto side), and set the Selecting Dial from OFF to ISO. The LCD will indicate "OFF c" for five seconds to tell you that the Lens Cap Sensor has been turned off.

To turn on the Lens Cap Sensor again, slide the Zoom Lever up and set the Selecting Dial from OFF to ISO in the same manner as to turn off the Lens Cap Sensor. The LCD will indicate "ON c" for five seconds to tell you that the Lens Cap Sensor has been turned on.

## V. A WORD ON THE CAMERA'S AUTOFOCUS SYSTEM

### Principle

Your camera's autofocus system uses an active type method (trigonometrical distance measurement with infrared rays) and a passive type method (detection of phase difference) for precise focusing. While the passive type method takes care of distant objects that cannot be reached by infrared rays, the active type method takes care of low-contrast objects (at near distances) that are not suited for the passive type autofocus method, thereby increasing the reliability of the autofocus system to improve the focusing accuracy.

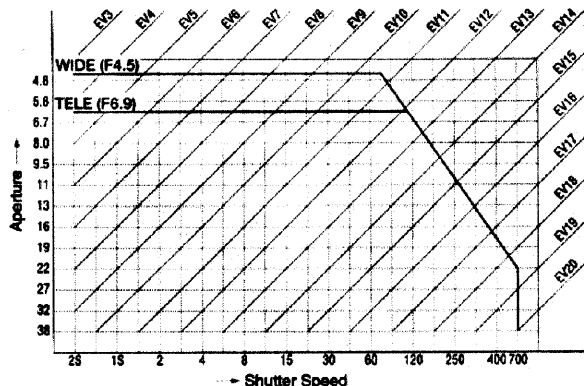
### Objects that are not suited for autofocusing

In the following cases, the Lens may not be able to focus on the subject or the displayed distance may differ extremely with the actual subject distance.

- Fast-moving objects
- Objects that have no definite shape, such as smoke and flame (especially on active-type autofocusing).
- If you are shooting through a window glass.
- If your subject cannot reflect enough light, such as a bunch of hair and fur.
- Strongly reflecting objects, such as a mirror or car body (especially on passive-type autofocusing).
- Extremely low-contrast objects.
- Objects which have vertical lines only.

## REFERENCE DATA

- Programmed Exposure Diagram  
[Programmed auto exposure] P mode (ISO 100)





# FUJIFILM

## FUJI PHOTO FILM CO., LTD.

26-30, Nishiazabu 2-chome, Minato-ku, Tokyo 106-8620, Japan.

### <FUJIFILM ABROAD>

#### In North America

**FUJI PHOTO FILM U.S.A., INC.**  
566 Tanager Road, Elmsford, N.Y. 10523, U.S.A  
**FUJI PHOTO FILM CANADA INC.**  
275 Britannia Road East, Mississauga, Ontario, L4Z 2E7, Canada  
**FUJI PHOTO FILM HAWAII, INC.**

#### In Europe

1650 Kalaniana'opuhi Avenue, Honolulu, Hawaii 96826, U.S.A.  
**FUJI PHOTO FILM (EUROPE) G.m.b.H.**  
Haseenstrasse 31, 40549 Düsseldorf, Germany  
**FUJI PHOTO FILM (U.K.) LTD.**  
Fuji Film House, 126 Finchley Road, Swiss Cottage, London NW3 6JH, England  
**FUJI FILM ESPAÑA, S.A.**

#### In South America

Aragon, 180, 08011-Barcelona, Spain  
**FUJI PHOTO FILM DO BRASIL LTDA.**  
Avenida Versador José Dória No. 3.400, Campo Belo- CEP 04.604  
Cx. Postal 9.956., São Paulo-SP, Brazil

#### In Asia

**FUJI PHOTO FILM CO., LTD. HONG KONG OFFICE**  
Room 516, Sun Plaza, 28 Canton Road, Tsim Sha Tsui, Kowloon, Hong Kong  
**FUJI PHOTO FILM (SINGAPORE) PTE. LTD.**  
10 New Industrial Road, Singapore 526201  
**FUJI PHOTO FILM (THAILAND) LTD.**  
S.P. Building, 6th Floor, 388 Phaholyothin Road, Bangkok 10400, Thailand  
**FUJI PHOTO FILM (MALAYSIA) SDN. BHD.**  
Letter Box 3, 3rd Floor Office Block 1, Crystal Plaza Lot 4, Jalan 51A/223  
46100 Petaling Jaya Selangor Darul Ehsan Malaysia

**FUJI PHOTO FILM CO., LTD., TAIPEI OFFICE**  
Rm. 801, Hung Chong Bldg., No.38, Sec. 6, Min Chuan E. Road, Taipei 11412, Taiwan, Republic of China  
**FUJI PHOTO FILM CO., LTD., SEOUL OFFICE**

Samdock Bldg. 8F., 144-1, Samsung-Dong, Kam Nam-ku, Seoul 135-090 Korea  
**FUJI PHOTO FILM CO., LTD., BEIJING REPRESENTATIVE OFFICE**  
Beijing Fortune Bldg. No. 817, 5, Dong Sanhuan Bei-lu, Chaoyang District, Beijing, China 100004

**FUJI PHOTO FILM CO., LTD., HO CHI MINH OFFICE**  
29-31 Ton That Thiep St., Q1 Ho Chi Minh City, Vietnam  
**FUJI PHOTO FILM CO., LTD., NEW DELHI OFFICE**

#### In Oceania

Le Meridian Commercial Tower 8F, Jangpath, New Delhi 110001, India  
**FUJI PHOTO FILM CO., LTD., SYDNEY REPRESENTATIVE OFFICE**  
c/o Hanimax Pty. Limited, Old Pittwater Road, Brookvale, N.S.W. 2100, Australia

#### In Middle East

**FUJI PHOTO FILM CO., LTD., DUBAI OFFICE**  
No. 46-17, L.O.B. No. 4, P.O. BOX 17212, Jebel Ali, Dubai, U.A.E.

Printed in Japan



This product is in conformity with Directive 89/336/EEC.  
Dieses Produkt entspricht der Direktive 89/336/EEC.  
Ce produit est conforme à la Directive 89/336/EEC.  
Producto conforme con la Normativa 89/336/EEC.  
本產品符號 89/336/EEC 指令。

Printed on recycled paper  
Gedruckt auf wiederverwertetem Papier  
Imprimé sur papier recyclé  
Impreso en papel reciclado  
本小冊子使用再生紙印刷。

FGS-890104-FG-01