

www.butkus.us

PENTACON
PRAKTICA
super TL

I N S T R U C T I O N S F O R U S E

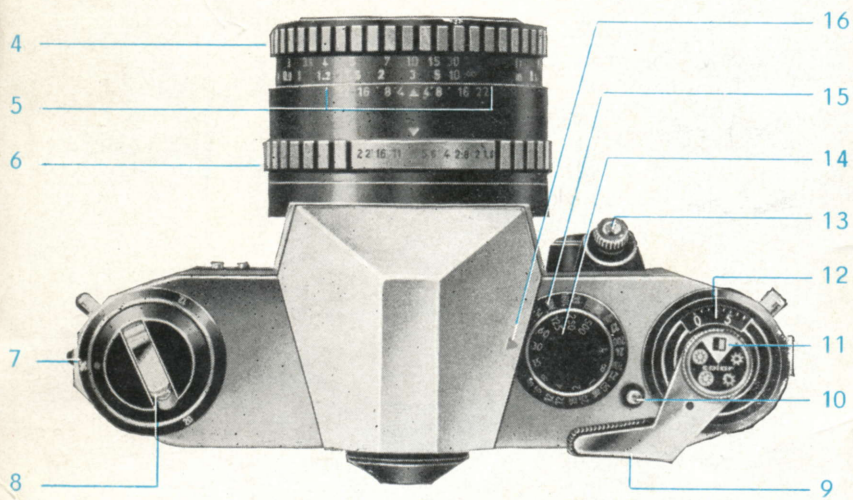

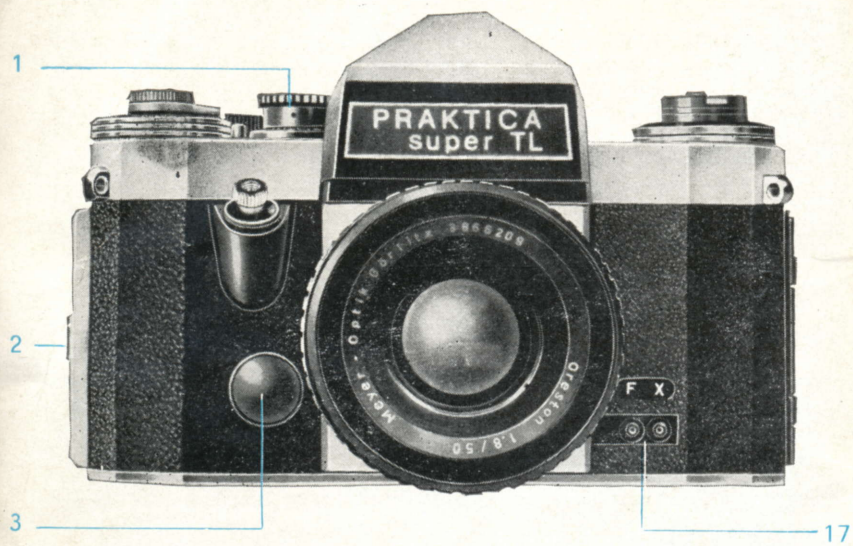

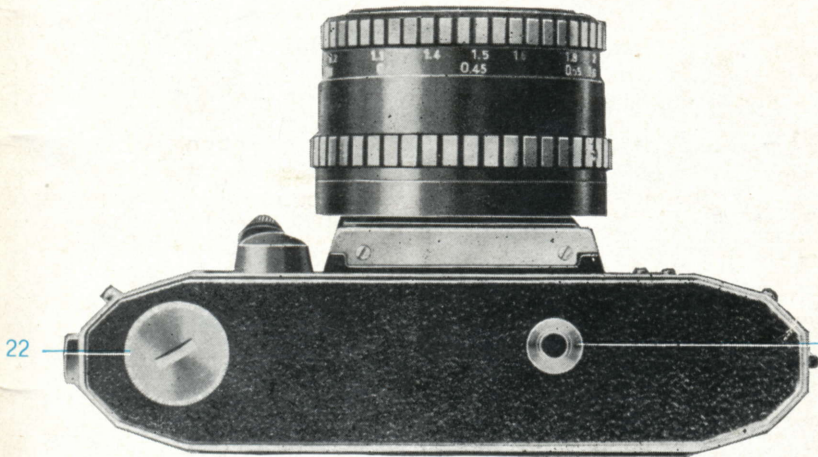
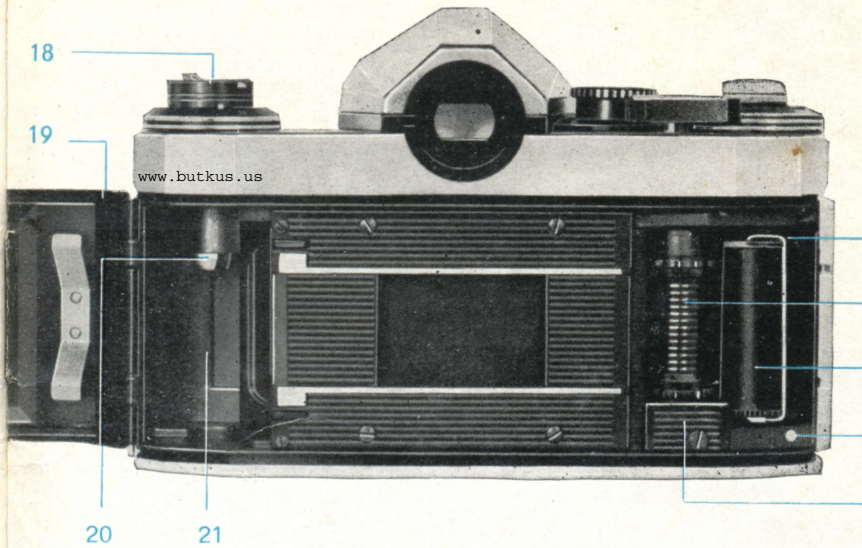



This manual is for reference and historical purposes, all rights reserved.

This page is copyright© by M. Butkus, NJ.

This page may not be sold or distributed without the expressed permission of the producer

I have no connection with any camera company

On-line camera manual library

This is the full text and images from the manual. This may take 3 full minutes for the PDF file to download.

If you find this manual useful, how about a donation of \$3 to: M. Butkus, 29 Lake Ave., High Bridge, NJ 08829-1701 and send your e-mail address so I can thank you. Most other places would charge you \$7.50 for a electronic copy or \$18.00 for a hard to read Xerox copy.

This will allow me to continue to buy new manuals and pay their shipping costs.

It'll make you feel better, won't it?

**If you use Pay Pal or wish to use your credit card,
click on the secure site on my main page.**

Donate: www.PayPal.me/butkus

venmo: @mike-butkus-camera

Control Parts of the PRACTICA super TL

- 1 Film speed indicator
- 2 Latch for camera back
- 3 Meter key
- 4 Distance setting ring
- 5 Depth-of-field indicator
- 6 Diaphragm setting ring
- 7 Length-of-film reminder dial
- 8 Rewind crank
- 9 Cocking lever
- 10 Rewind release knob
- 11 Film type reminder dial
- 12 Exposure counter
- 13 Shutter release
- 14 Setting knob for shutter speeds
- 15 Dial showing film speeds
- 16 Exposure speed index
- 17 Flash socket
- 18 Rewind knob
- 19 Camera back
- 20 Carrier shaft
- 21 Cartridge chamber
- 22 Cover plate for power source
- 23 Tripod socket
- 24 Supporting piece for PL system
- 25 Marking point
- 26 Take-up spool
- 27 Transport sprocket
- 28 Wire bracket

While congratulating you on having acquired a PRAKTICA super TL, we would also request you to treat your camera kindly. Please take your time and read these Instructions for Use carefully.

Although of very rigid build, the PRAKTICA super TL is, nevertheless, a mechanical-optical precision instrument. Handled with care, it will reward you, even when subjected to rigorous conditions, by giving you beautiful photos.

On the inside cover pages you will find specified illustrations. The reference numbers in the text are printed in parentheses.

Special Features of the PRAKTICA super TL

- The PRAKTICA super TL is the converging point of the modern PRAKTICA single-lens reflex system. Key to this new system in photography is a newly devised method of automatic exposure based on the principle of internally measuring the light in the path of rays by means of a photo resistor.
- All values influencing the exposure, such as image angle, aperture, and extension factors for filters and in macro and micro work, are taken into account by the meter system. The measuring range extends from 2 apostilbs at $f/2$ to 250,000 apostilbs at $f/22$.
- Meter key connected to the metering system.
- Power source for the metering system has a working life of approximately two years.
- Meter needle appears in finder image.
- Range of film speeds from 9 DIN to 33 DIN or 6 ASA to 1600 ASA.
- Focal-plane shutter giving exposure speeds from 1 sec. to $1/500$ sec., \leq and B.
- Non-rotating dial for setting the shutter speeds.

- Prism viewfinder with bright, unreversed and parallax-free finder image. Due to the instant return mirror it is almost continuously visible.
- Two possibilities of focusing on the bright viewfinder image in micro-prism screen or groundglass circle.
- Synchronization for flash bulbs and electronic flash.
- Conveniently placed rapid wind lever and smoothly working oblique shutter release with locking device against accidental triggering.
- Shutter cocking mechanism and film transport are coupled and provided with locking device against double exposures and blanks.
- Automatic exposure counter.
- Automatic pressure diaphragm.
- Film loading facilitated by PL System.
- Swing-out rewind crank, self-locking rewind release knob.
- Interchangeable lenses from 20 mm to 1000 mm focal length, with PRAKTICA fitting, mostly with automatic pressure diaphragm.
- Wide range of PRAKTICA accessories.

Internal Measuring System of the PRAKTICA super TL

The path of rays forming the image of the object is conducted through the lens, by way of the instant return mirror, the Fresnel lens with focusing system, the pentaprism and the ocular to the eye of the viewer. Focusing is performed by rotation of the distance setting ring on the lens mount with the aid of the focusing system. Part of the light coming from the entire image area is deflected from the path of rays of the viewfinder to the photo resistor. Any light particles outside of the image angle, which might cause incorrect measuring, are thus cut off. All correcting factors to be observed hitherto for the use of filters, close-up and micro attachments are, in the internal metering system, directly taken into account. The meter reading is revealed in the finder image by the meter needle of a microammeter. Power source of the exposure meter system is a mercury oxide battery installed in the base of the camera. Pressure on the meter key closes the measuring circuit.

How the PRAKTICA super TL works

When the shutter release is depressed the instant return mirror moves out of its viewing position into picture taking position. At the same time, the pressure diaphragm of the lens is automatically closed down to the selected aperture. As soon as the focal-plane shutter has run down the instant return mirror springs back into viewing position and the pressure diaphragm is fully opened again. This means that the finder image is — except for the moment of the exposure — continuously visible. In the single-lens reflex system — even if interchangeable lenses of extremely long focal lengths, or close-up attachments are being used — there is never any danger of parallax.

The finder image is somewhat smaller than the final negative. Everything visible in the finder image is sure to appear on the film, which means that the finder image may be utilized to its very edges.

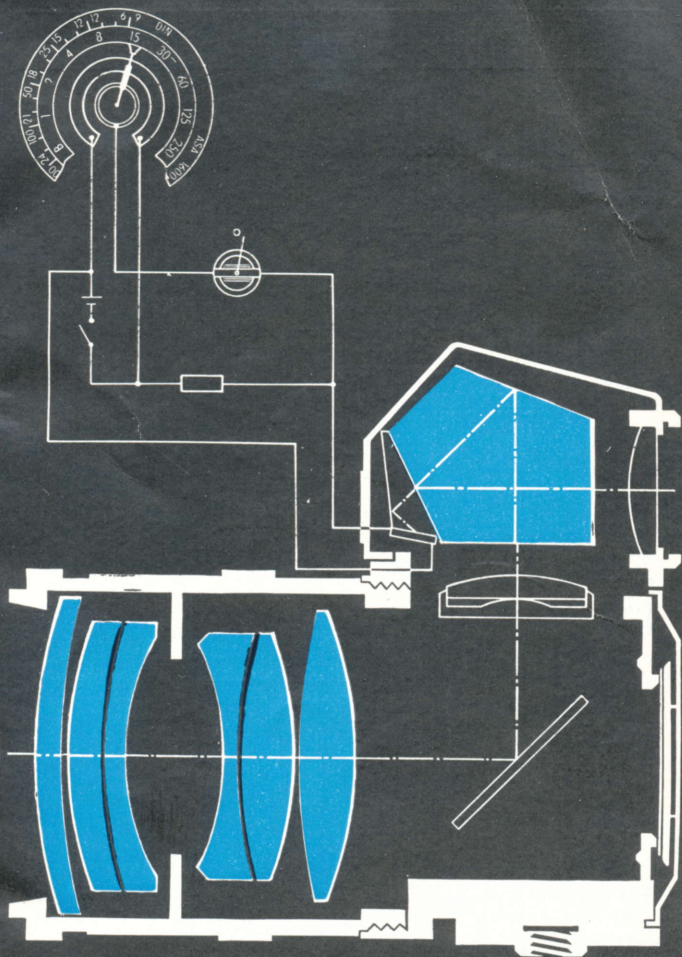

Abridged Instructions and Contents

- A** **Opening the camera back** Detailed description
page 10
- B** **Inserting the film** page 10
- Pull out rewind knob (18) as far as it will go. Place full cartridge into cartridge chamber (21). Push rewind knob (18) in again. Push lower perforation of film from above underneath the little support (24), across the transport sprocket (27), place beginning of film strip on to core of take-up spool (26) as far as marking point (25). Wire bracket (28) must not stand upwards!
- C** **Closing the camera back** page 12
- D** **Setting the film speed** page 12
- Lift setting knob (14) and rotate it either way. The white dot (1) on the perimeter of the setting knob (14) has to stand against the required film speed numeral on dial (15).
- E** **Setting the type of film** page 12
- Rotate film type reminder dial (11) until the symbol marking the film meets the red dot.
- F** **Preparing for the exposure** page 14
- Actuate shutter release (13) and cocking lever (9) until exposure counter (12) stands on number 1.

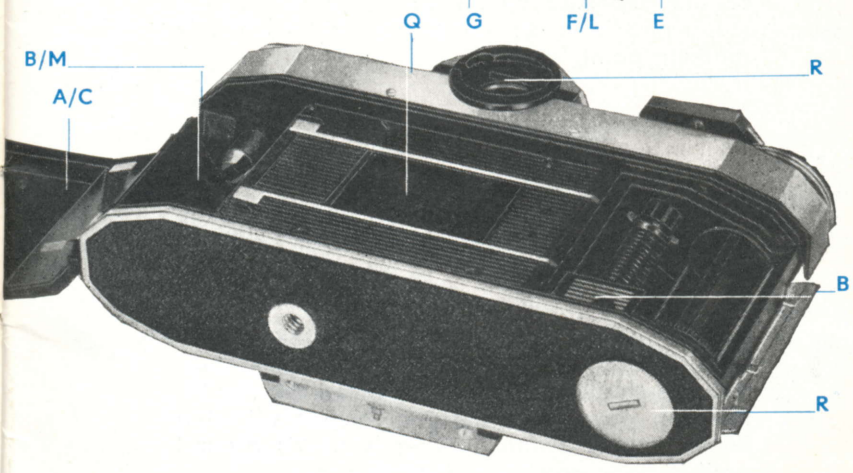
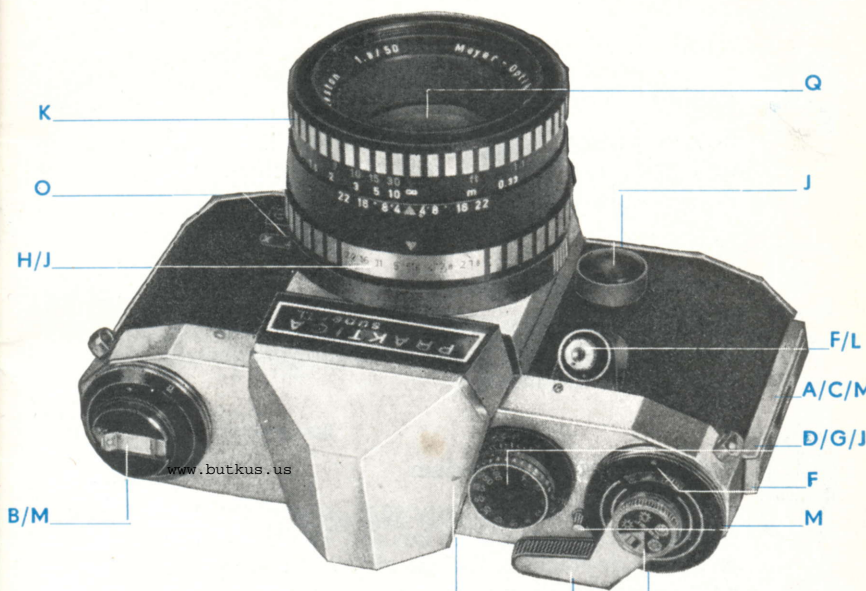

Abridged Instructions and ContentsDetailed
description**Setting the exposure speed**

page 16

Rotate setting knob (14) (without lifting it) until the desired speed numeral coincides with red triangle (16).

**Setting the diaphragm**

page 18

Rotate diaphragm setting ring (6) on lens mount to bring the desired diaphragm numeral against the red mark.

**Automatic exposure system**

page 20

Preselect either the exposure speed or the aperture. Depress meter key (3). While the key is being depressed, adjust either the aperture or the exposure speed so as to centre the meter needle in the image field to the circular marking point.

**Focusing**

page 24

Rotate distance setting ring (4) until the image in the circular micro-prism screen is perfectly sharp.

**Releasing and cocking the shutter**

page 28

Actuate shutter release (13). When the shutter has run down a red signal appears in the finder image. Swing cocking lever (9) around until it stops and move it back again.

- | | | |
|----------|--|---------|
| M | Changing the film | page 30 |
| | After the last exposure, depress rewind release knob (10). Swing out rewind crank (8) on rewind knob (18). Rewind film in direction of arrow. Open camera back (19). Remove cartridge from camera. | |
| N | Exchanging lenses | page 32 |
| O | Flash exposures | page 34 |
| P | Exchanging the power source | page 36 |
| Q | Maintenance of camera and lens | page 38 |
| R | Accessories | page 38 |

These abridged instructions are a short summary of the main points in the Instructions for Use. These points deserve special attention. They are, however, not a substitute for the valuable information which you will only be able to gain by reading the complete instructions.

A**Opening the camera back**

Push latch (2) for camera back in direction of arrow. Open camera back, and the exposure counter (12) will automatically jump to zero.

B**inserting the film**

The PRAKTICA super TL accepts any type of perforated 35 mm film in commercially available standard cartridges. The cartridges contain film lengths for 36 or 20 exposures in the 24 × 36 mm picture format — either on black-and-white film, on colour negative film for colour prints, or on colour reversal film for colour transparencies.

The cartridges are light tight. Nevertheless, we would advise you not to insert films in direct sunlight — the shade provided by your own body will suffice. Pull out rewind knob (18) as far as it will go. Place cartridge into cartridge chamber (21) and push rewind knob (18) — with slight backward and forward movements — right back into the camera. Carrier shaft (20) will engage in the core of the cartridge. Push lower perforation of film from above underneath the little support (24) over the transport sprocket (27), place beginning of film strip on to the core of take-up spool (26) as far as marking point (25).

The wire bracket (28) must not stand upwards! Should this be the case, rotate lower milled ring of take-up spool (26) to bring the brackets to horizontal position.

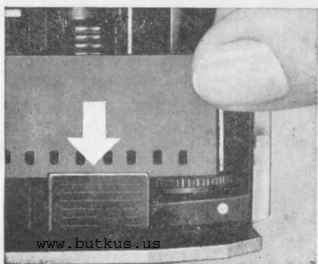
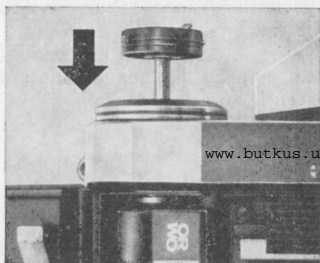
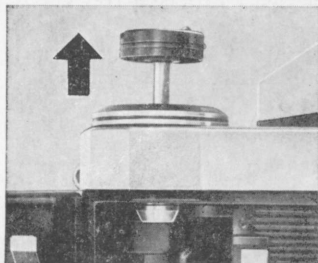
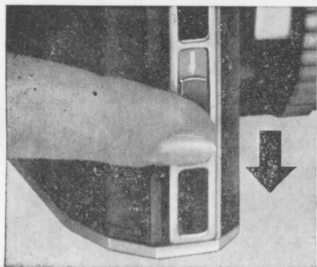

C**Closing the camera back**

Close camera back (19) and press it on tightly. It locks automatically.

D**Setting the film speed**

Lift setting knob (14) and rotate it either way. Dial (15) below the knob remains in stationary position. The white dot (1) on the perimeter of setting knob (14) has to be brought against the required film speed numeral on dial (15). Setting knob (14), when lowered, clicks in.

E**Type of film and length of film**

The film type reminder dial (11) is to help you remember what kind of film you have loaded in your camera.

The symbol corresponding to your film is set against the red marking point. You will thus always know which type of film you have in your camera.

The length-of-film reminder dial (7) serves to mark the number of exposures possible with the film in the camera.

The selector of the length-of-film reminder dial (7) has to be set to the corresponding number (12, 20 or 36).

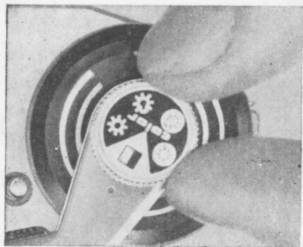
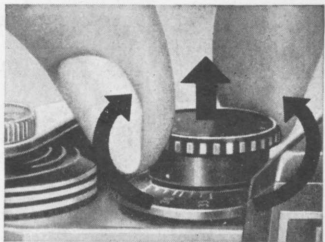
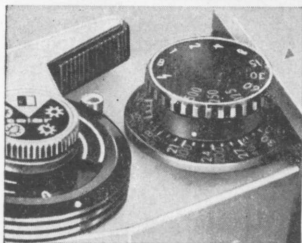
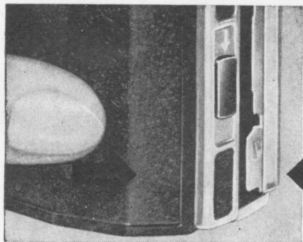

Black-and white film



Colour reversal film for daylight



Colour reversal film for artificial light



Colour negative film for daylight



Colour negative film for artificial light

F**Preparing for the exposure**

Swing cocking lever (9) around as far as it will go and let it glide back. (Move cocking lever only in winding direction. Forced movement in the opposite direction will cause damage!)

Actuate shutter release (13).

To avoid inadvertent tripping, the shutter release (13) is provided with a locking device. The release mechanism is locked when the red dots on the knob and on the outer ring meet. The mechanism is unlocked by rotation of the knob through 90°.

Repeat the cocking and releasing procedure described above once more and then cock the shutter again. Rewind knob (18) moves simultaneously in anti-clockwise direction.

The automatic exposure counter (12) now stands on frame number 1. Special setting of the exposure counter is not necessary since it starts working automatically when the camera back is closed.

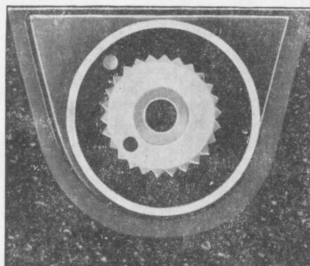
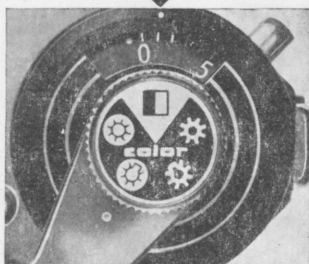
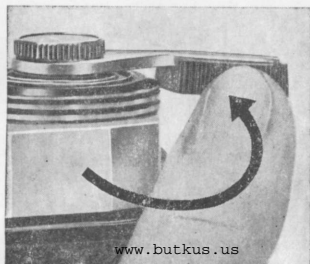

Shutter can be released

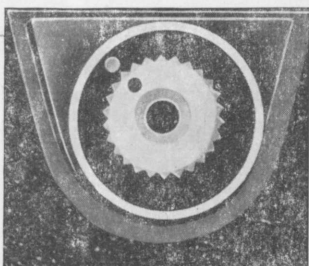

Shutter release locked

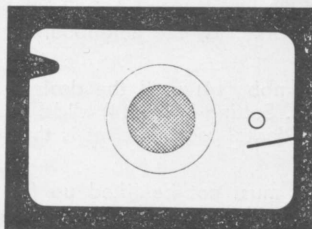

Shutter cannot be released!
Cock shutter

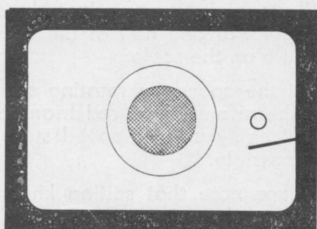

Camera ready for exposing

The focal-plane shutter of the PRAKTICA super TL is calibrated for exposure speeds from 1 sec. to $\frac{1}{500}$ sec. The B setting is for any desired length of time. (The shutter remains open as long as the release knob (13) is depressed or kept open by means of a cable release with locking device.) For flashlight exposures please refer to Section O.

The numerals on the setting knob stand for the exposure speeds as follows:

Red numerals long exposure time

B, 1 = 1 sec., 2 = $\frac{1}{2}$ sec., 4 = $\frac{1}{4}$ sec., 8 = $\frac{1}{8}$ sec.,
15 = $\frac{1}{15}$ sec.

For these exposures a tripod has to be used.

White numerals short exposure time

30 = $\frac{1}{30}$ sec., 60 = $\frac{1}{60}$ sec., 125 = $\frac{1}{125}$ sec., 250 = $\frac{1}{250}$ sec.,
500 = $\frac{1}{500}$ sec.

The speeds are graduated so that each numeral indicates double, or one half of the speed marked by the neighbouring figure on the scale.

Set the speed by rotating setting knob (14) until the desired numeral meets the red triangle (16). Setting knob (14) clicks in noticeably at each speed stop, accidental readjustment is thus impossible.

Please note that setting knob (14) must not be lifted up for setting the exposure speeds (this is done only to mark the speed of the film). The exposure speeds can be set either before or after the shutter has been cocked.

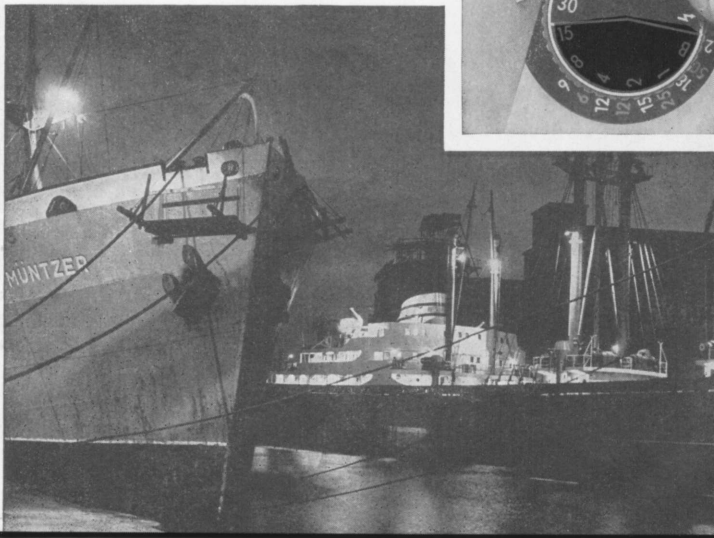
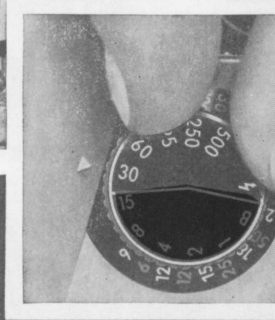

H**Setting the diaphragm**

On the lenses with automatic pressure diaphragm in the PRAKTICA super TL the desired aperture numeral on the diaphragm setting ring (6) need only to be brought to meet the red index on the lens mount. The diaphragm closes automatically when the shutter release is depressed.

For the purpose of checking the depth of field, most lenses can be stopped down to the preselected value by a manually operable lever before the exposure is made.

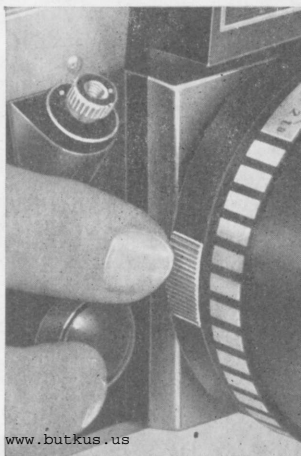
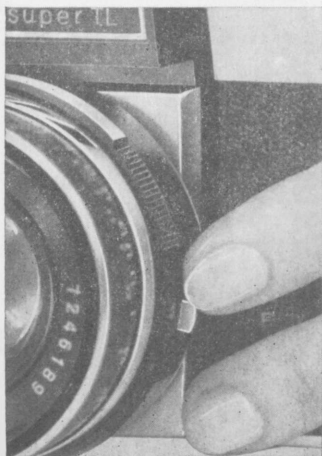

I**Automatic exposure system**

If lenses with automatic pressure diaphragm are being used, two ways of metering are possible with the automatic exposure system of the PRAKTICA super TL.

Exposure reading with shutter speed preselected

(e. g. for objects in motion)

Shutter speed is set! Depress meter key (3) and rotate diaphragm setting ring (6) on lens mount until the meter needle in the image field is centered to the circular mark.

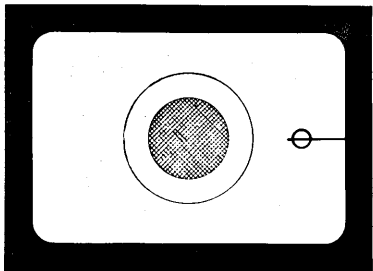

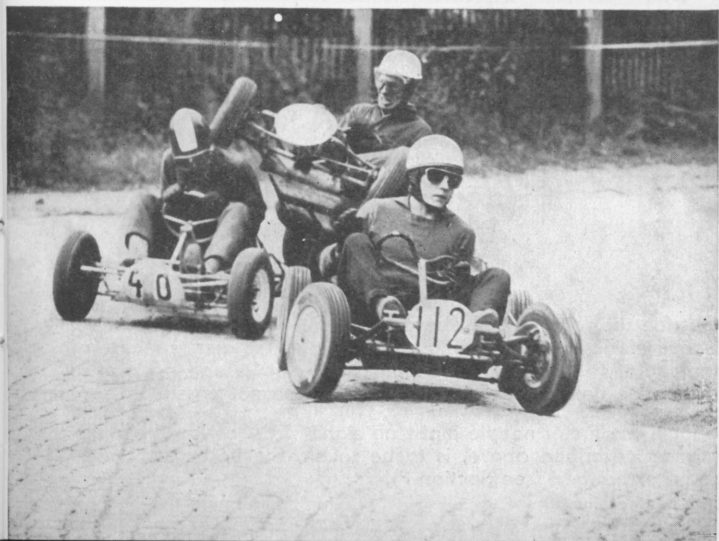

Exposure reading with aperture preselected (e. g. for a desired depth of field)

Aperture is set! Depress meter key (3) and rotate setting knob (14) — using only click stops — until the meter needle is centered to the circular mark. Should the click stop settings of knob (14) not permit a perfectly accurate centering of the needle, fine adjustment has to be made by means of diaphragm setting ring (6). On pressure of meter key (3) the diaphragm is automatically closed to the preselected value.

Measuring range of the PRAKTICA super TL

Film speed		Exposure speed
DIN	ASA	
9	6	1 sec. . . . $\frac{1}{60}$ sec.
12	12	1 sec. . . . $\frac{1}{125}$ sec.
15	25	1 sec. . . . $\frac{1}{250}$ sec.
18	50	1 sec. . . . $\frac{1}{500}$ sec.
21	100	1 sec. . . . $\frac{1}{500}$ sec.
24	200	$\frac{1}{2}$ sec. . . . $\frac{1}{500}$ sec.
27	400	$\frac{1}{4}$ sec. . . . $\frac{1}{500}$ sec.
30	800	$\frac{1}{8}$ sec. . . . $\frac{1}{500}$ sec.
33	1600	$\frac{1}{15}$ sec. . . . $\frac{1}{500}$ sec.

Outside the range given above, the meter system of the camera is out of action for the film speeds and shutter speeds as indicated. The meter needle then stands in its end position in the image field, and exposure readings are not possible.

Should the meter needle make no signs of deflecting if a reading, as described above, is to be taken, the battery will have to be exchanged (see Section P).

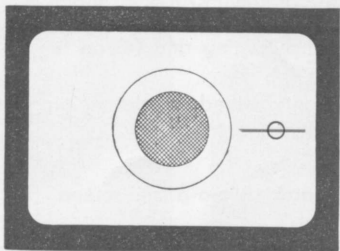
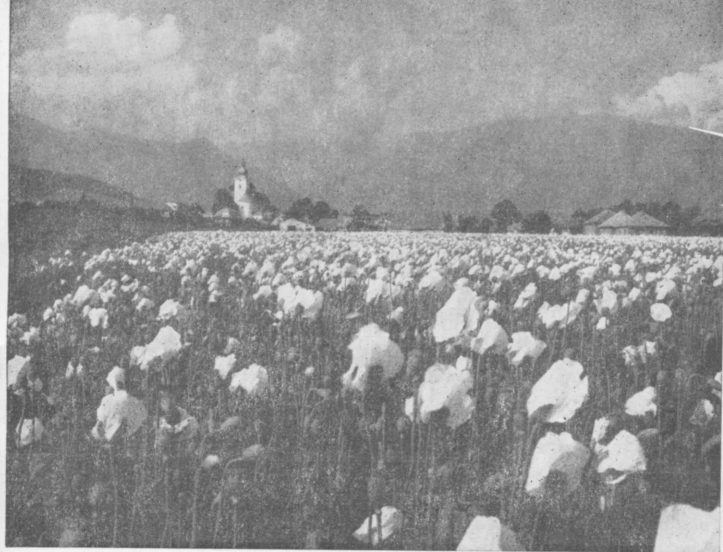

Exposure reading with lenses without automatic pressure diaphragm

In principle, exposure meter readings as described above are possible also with these types of lenses. Only the diaphragm has to be set to the desired value by hand. It is advisable, with such lenses, to do the focusing **before** taking the meter reading, since the diaphragm does not reopen automatically.

Owing to the construction of their barrels, some of the older type lenses protrude into the space accommodating the diaphragm mechanism and can, therefore, not be used, as they would render it impossible to release the shutter.

K

Focusing

The prism viewfinder of the PRAKTICA super TL is fitted with a Fresnel lens to brighten up the image. Focusing is performed by rotating the distance setting ring (4) on the lens mount.

There are two different methods of determining the sharpness of the image:

Focusing on the central micro-prism screen

Correct focusing is achieved as soon as the image in the micro-prism screen is clear and free from fuzziness.

If the image looks fuzzy or crumbles into screen elements, it is out of focus.

Focusing is extremely reliable owing to the apparent quick transition from unsharpness to sharpness and vice versa. It is advisable to do the focusing with the lens at the widest aperture (smallest diaphragm numeral).

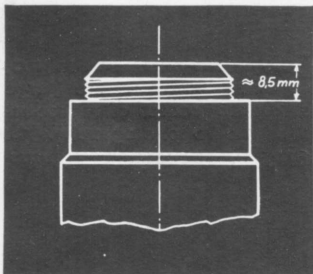

To be used

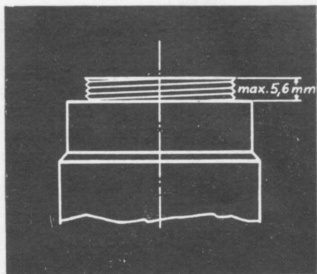

Not to be used



Micro-prism screen
is fuzzy = unsharp

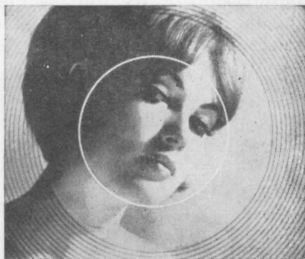

Micro-prism screen
not fuzzy = sharp

Focusing on the circular groundglass area

The groundglass area encircling the micro-prism screen may be used for focusing with the lens at a small aperture (large diaphragm numeral) or in case of greater scales of reproduction as, for instance, in close-up or macro photography. The remaining section of the finder image is not meant for focusing.

Depth-of-field indication (5)

These are the figures on the right and left of the red focusing index. The exposure distance is set against the red mark. On the left of the mark, next to the desired diaphragm numeral, you read on the distance scale where the depth of definition begins, and on the right, where it ends.

For the 50 mm Pancolar f/1.8 from Jena

In accordance with the aperture setting, the two black marks refer to the depth of field. The distance figure stands against the red index. On its left you see where the depth of definition begins and on its right, where it ends: You move forward from the marks on the white or black rim surfaces towards the distance scale.

Depth of field can also be checked in the viewfinder image on actuation of meter key (3), or of the manual stop down lever on the lens mount after the exposure reading has been taken. All readings on the distance scale are in relation to the position of the image plane. Taking lens and finder lens being one and the same, there is no parallax error. Persons with faulty eyesight may insert a corrective lens in special mount into the eyepiece of the viewfinder (connecting point for further special finder equipment — see Section R).

For infra-red exposures the focusing point has to be slightly modified. By rotation of distance setting ring (4) the distance reading which, after focusing, stands next to the red indicator, has to be moved to meet the red dot (infra-red dot) next to the indicator. Thus, the image produced by the no longer visible infra-red rays, which is somewhat farther away from the lens than the one designed by the visible light, is brought into correct position in relation to the film.

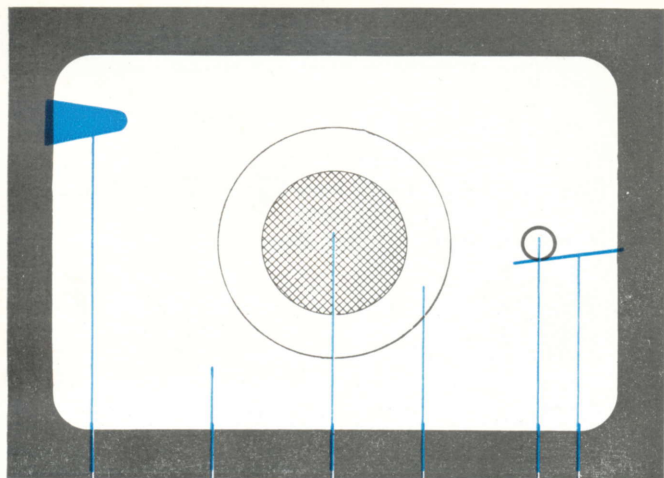

Signal

Fresnel lens

Micro-prism screen

Groundglass circle

Circular mark

Meter needle circle

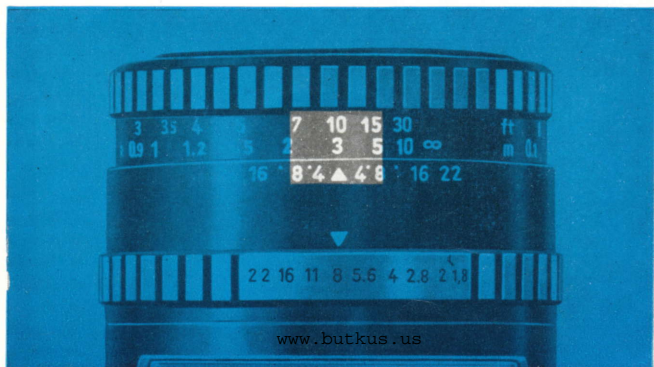

Before releasing the shutter, please note the following:

1. Make sure that the shutter release is unlocked (Section F).
2. For exposure speeds slower than $1/30$ sec. it is advisable to use a tripod and a cable release.
3. If signal is visible in viewfinder, the camera is not ready for exposing! Cock the shutter.

When taking your picture we advise you to hold your PRAK-TICA super TL so that it lies firmly in both hands and you are able to actuate the shutter release (13) comfortably.

The shutter release (13) has to be depressed smoothly — never with a jerk — as far as it will go, until the shutter has run down. Do not leave hold of the body release, or cable release, before the shutter closes completely, otherwise the diaphragm will open before its time. (This refers especially to the slower exposure speeds.)

When once released, the shutter cannot be released a second time (lock against double exposure).

After release of the shutter, a red signal appears in the upper left-hand corner of the image field.

Cocking lever (9) has to be swung around again as far as it will go and moved back smoothly (see Section F). Once more the camera is ready for action.

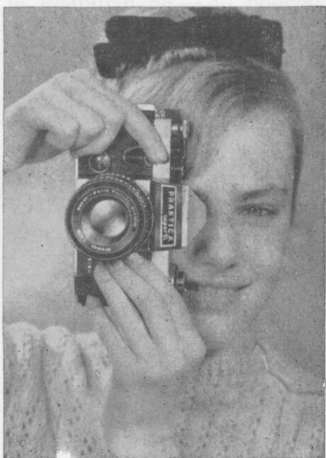
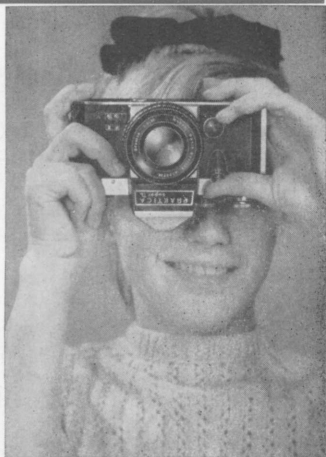
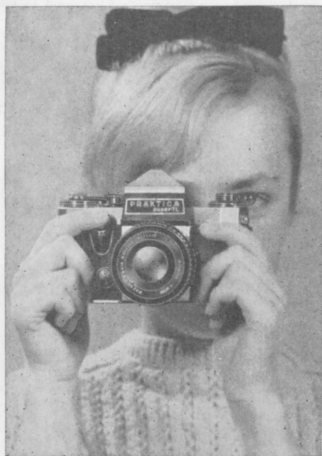

M**Changing the film**

When exposure counter (12) shows the figure indicating the number of frames marked on the film packet (12, 20, or 36), the film has to be exchanged.

Depress rewind release knob (10). Knob remains locked in this position. Swing out rewind crank (8) on rewind knob (18). Rotate rewind knob (18), not too quickly, in the direction of the engraved arrow. Rewinding too quickly causes electrostatic charge and statics on the film.

Towards the beginning of the film strip greater resistance becomes noticeable. After this, the crank (8) turns more easily, a sign that the film is fully rewound. Fold rewind crank (8) down again.

Open camera back (19) by pushing latch (2) in direction of arrow.

Pull out rewind knob (18) as far as it will go and remove the cartridge.

On rewinding of cocking lever (9) or — should the shutter be wound up — on actuation of shutter release (13), the rewind release knob returns automatically to its initial position.

Should you have attempted to expose more frames than the number marked on your film packet, it may happen that cocking lever (9) gets jammed and cannot be swung around completely. In this case depress rewind release knob (10), at the same time swinging cocking lever (9) until it stops. The film can then be rewound as described above.

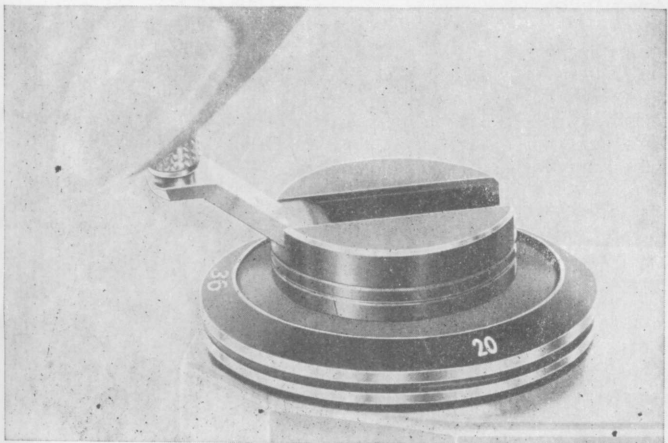
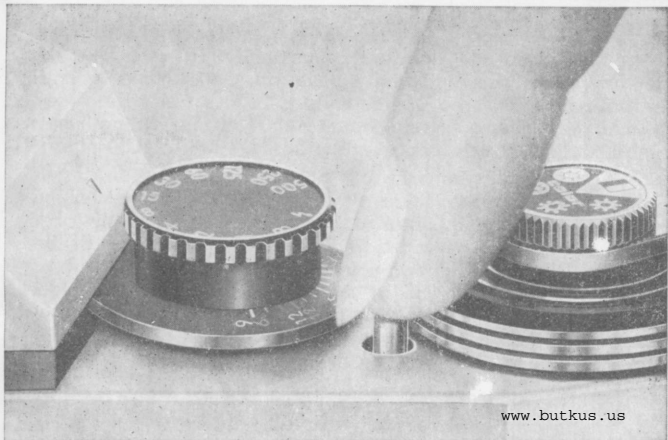

The PRAKTICA super TL lenses are interchangeable regardless of their distance and aperture adjustability. Take hold of the lens mount, as shown in the illustration, and turn it in anti-clockwise direction. The exchange lens is inserted accordingly. The camera accepts all the lenses with PRAKTICA fitting (screw thread M 42×1) with focal lengths from 20 mm to 1000 mm.

Focusing, in connection with all the interchangeable lenses, is performed in the prism finder of the PRAKTICA super TL. Since the taking lens also acts as finder lens you obtain, at any focal length, a finder image coinciding, free from parallax, with the picture which you will get on your film.

Owing to the construction of their barrels some of the older type lenses protrude into the space accomodating the diaphragm mechanism. Such lenses cannot be used as they would render it impossible to release the shutter (see Section I).

Interchangeable lenses

Zeiss Flektogon	20 mm f/4	APD
Meyer Orestegon	29 mm f/2,8	APD
Meyer Lydith	30 mm f/3,5	PD
Zeiss Flektogon	35 mm f/2,8	APD
Zeiss Pancolar	50 mm f/1,8	APD
Meyer Oreston	50 mm f/1,8	APD
Meyer Domiplan	50 mm f/2,8	APD
Zeiss Tessar	50 mm f/2,8	APD
Zeiss Pancolar	55 mm f/1,4	APD
Zeiss Pancolar	75 mm f/1,4	APD
Meyer Orestor	100 mm f/2,8	APD/PD
aus Jena S	135 mm f/3,5	APD
Meyer Orestor	135 mm f/2,8	PD
aus Jena S	180 mm f/2,8	APD
Meyer Orestegor	200 mm f/4	PD
aus Jena S	300 mm f/4	APD
Meyer Orestegor	300 mm f/4	PD
Meyer Orestegor	500 mm f/5,6	PD
Zeiss Mirror Lens	500 mm f/4	
Zeiss Mirror Lens	1000 mm f/5,6	

APD = automatic pressure diaphragm,

PD = pre-set diaphragm



Flash exposures

There are two ways of synchronizing flash light to the PRACTICA super TL:

F synchronization

The F synchronization is designed to ignite short burning flash bulbs. It ignites the flash already before the image gate is completely uncovered. Thus it is possible to work with an exposure speed of $\frac{1}{30}$ sec.

Insert the flash cable into the flash socket (17) marked "F".

X synchronization

With the X synchronization the electronic flash, which flares up practically without delay, is ignited when the focal-plane shutter has completely uncovered the image gate. For the exposure, adjust speed setting knob (14) to the flash symbol \downarrow

This is equal to about $\frac{1}{40}$ sec., the shortest possible exposure speed to be employed with electronic flash.

Insert flash cable into the flash socket (17) marked "X".

Regarding aperture settings you will find directions, in form of so-called "guide numbers", given on the wrappings or in the literature coming with the bulbs and electronic flash units. The aperture of the lens and the distance between flash unit and subject are brought into balance on base of these guide numbers.

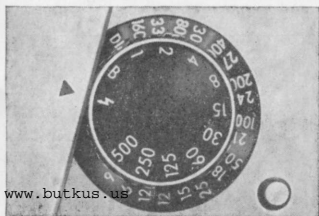
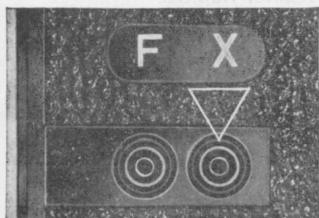
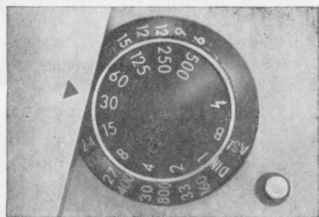
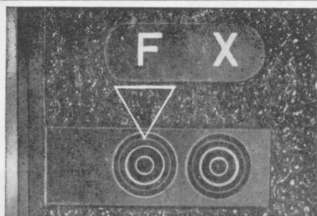

To find the correct aperture, divide the guide number for the flash in use by the flash-to-subject distance figure.

$$\text{Diaphragm number} = \frac{\text{guide number}}{\text{flash-to-subject distance}}$$

P

Exchanging the power source

Power source for the automatic exposure system is a Mallory Mercury Oxide Battery PX 625, PX 13, or a similar type, having a nominal voltage of 1.35 V.

Owing to the low consumption of current and the short working period for meter reading, the battery lasts about 2 years. To exchange batteries, screw out the cover (22) in the bottom of the camera with the aid of a coin. Insert new battery, making sure that the "+" sign is visible. Replace cover (22) and screw it tight.

Attention: Do not load the discarded battery or throw it into the fire. Both may cause an **explosion!**

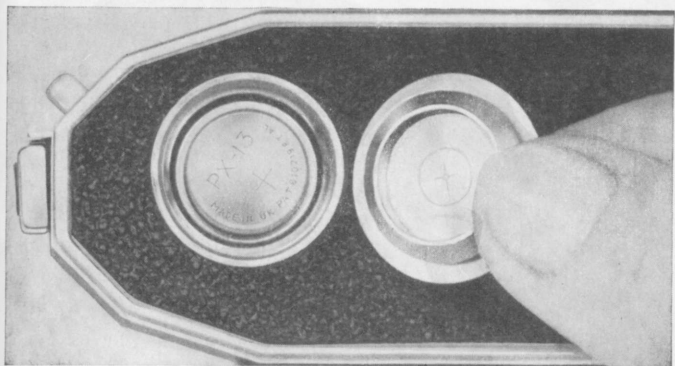
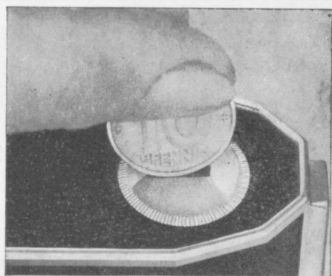
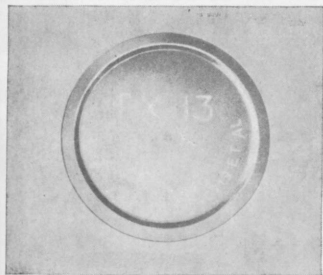

Q

Maintenance of camera and lens

Perfect functioning and lasting service of your PRAKTICA super TL depend very largely on careful maintenance and proper handling of the camera.

The PRAKTICA super TL is a highly valuable precision instrument. It must, therefore, be protected against shock and dust. (Use everready case.)

Never use force when operating the mechanism.

R

Accessories

Many interesting results in picture composition are obtainable with the aid of accessories.

Everready Case

It protects your valuable PRAKTICA super TL from dust and shock.



From time to time dust and film emulsion deposits have to be removed with a soft brush from cartridge chamber, spool chamber and film track. Do not touch the optical parts (lens, eyepiece of viewfinder, and mirror) with your fingers. Should you have done so accidentally, any fingerprints must be removed immediately with a soft brush or piece of fine linen.



adjustable

To be recommended if you are using your PRAK-TICA super TL without the ever-ready case, e. g. in combination with a flash unit.

Cable Release

Indispensable for the slower shutter speeds and for many special activities.



Lens Hood

Eliminates disturbing counter-light flares.

Filters

For correct rendition of colour values and special effects in black-and-white photography. Colour filters may be used only in combination with black-and-white film. UV filters and polarizing filters are also suitable for use with colour films.

Rubber Eye Cup

Keeps out stray light during focusing.

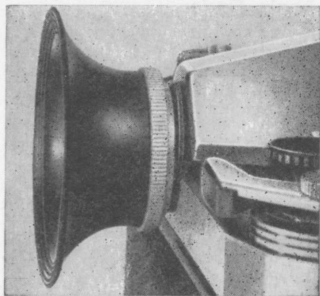

Mount for Correcting Lenses

For persons with faulty eyesight, to replace their spectacles.

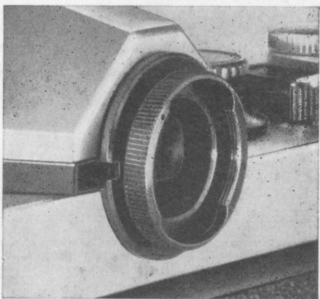

Focusing Telescope

Yields an additional 2,7 fold magnification of part of the finder image. Adjustable to faulty eyesight by means of a diopter focusing mount.

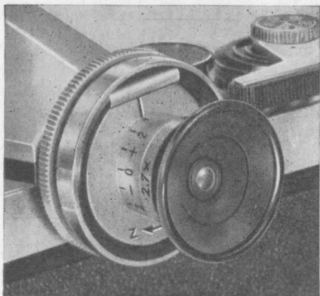

Angle Finder

Aid in focusing on subjects difficult of access. Is provided with a diopter focusing mount.



Accessory Shoe

Is attachable to the eye-piece of the viewfinder for fixing accessory equipment, e. g. flash units.

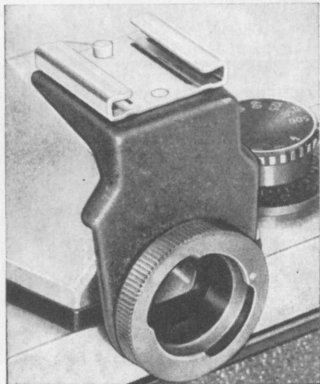

Intermediate Rings

To increase the scale of reproduction.

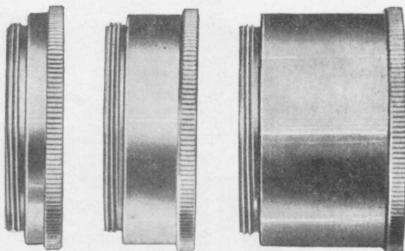

Intermediate Rings with Plunger

Permit maintaining operation of the automatic pressure diaphragm while extending scale of reproduction.

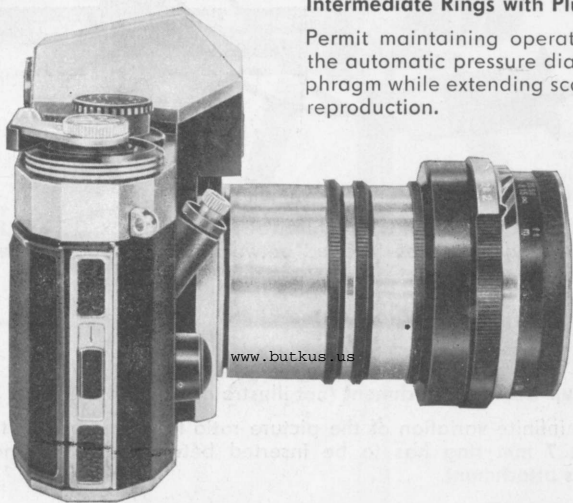

Reversing Ring

To insert lens into camera by its filter thread in order to achieve utmost sharpness of the image at ratios exceeding 1.5.



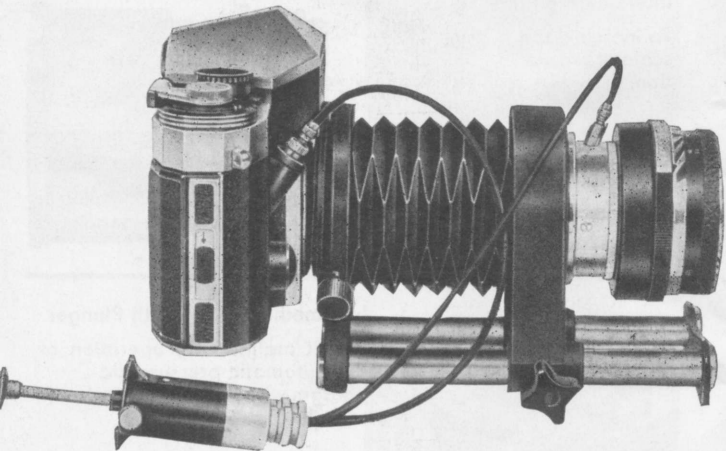

Miniature Close-up Bellows Attachment

For infinite variation of the picture ratio from approx. 0.9 to 2.8. A 7 mm ring has to be inserted between camera and bellows attachment.

Close-up Bellows Attachment (not illustrated)

Yields infinite variation of the picture ratio from approx. 0,9 to 4.7. A 7 mm ring has to be inserted between camera and bellows attachment.

Special Intermediate Ring with Double Cable Release

Keeps automatic diaphragm mechanism operative in connection with close-up bellows attachment and intermediate rings.

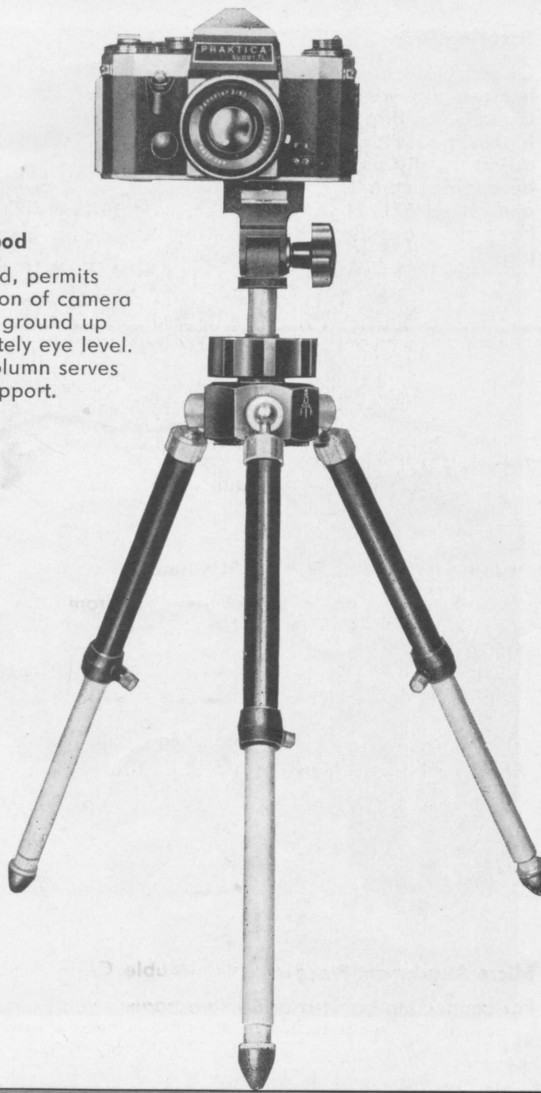

Universal Tripod

Extremely rigid, permits varying position of camera from close to ground up to approximately eye level. Adjustable column serves as camera support.

Focusing Slide

Of great advantage in close-up work on the universal tripod. Makes it possible to adjust the distance between camera and object without having to move the tripod.

www.butkus.us

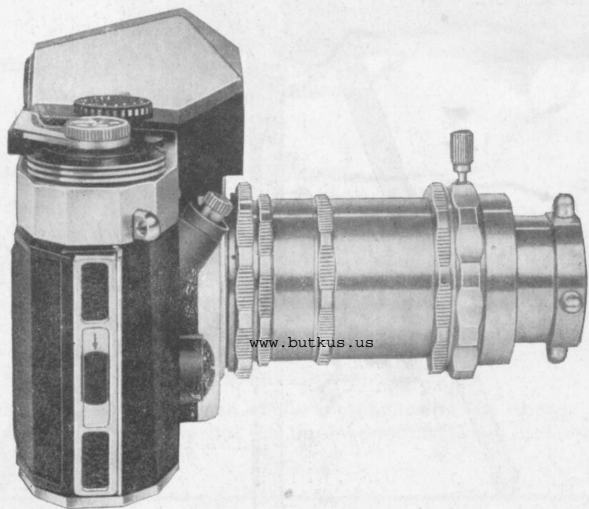
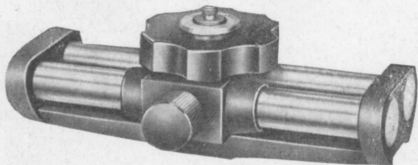

www.butkus.us

Micro Attachment Piece

For connecting camera and microscope.



Special literature on the above only briefly mentioned accessories for PRACTICA super TL will be sent on request. We ask you kindly to follow these Instructions for Use carefully. We can accept no liability for any damage which may be caused by improper handling of the equipment.

Kombinat

V E B P E N T A C O N D R E S D E N

Further development of the PRAKTICA super TL and its accessories may lead to slight alterations of the details given in this booklet.



PENTACON
PRAKTICA
super TL

K o m b i n a t V E B P E N T A C O N D R E S D E N
D E U T S C H E D E M O K R A T I S C H E R E P U B L I K