

This manual is for reference and historical purposes, all rights reserved.

This page is copyright© by M. Butkus, NJ.

This page may not be sold or distributed without the expressed permission of the producer

I have no connection with any camera company

On-line camera manual library

This is the full text and images from the manual. This may take 3 full minutes for the PDF file to download.

If you find this manual useful, how about a donation of \$3 to: M. Butkus, 29 Lake Ave., High Bridge, NJ 08829-1701 and send your e-mail address so I can thank you. Most other places would charge you \$7.50 for a electronic copy or \$18.00 for a hard to read Xerox copy.

This will allow me to continue to buy new manuals and pay their shipping costs.

It'll make you feel better, won't it?

**If you use Pay Pal or wish to use your credit card,
click on the secure site on my main page.**

PETRI FTEE

Instruction Book

L. E. Bluff



PETRI CAMERA COMPANY, INC.

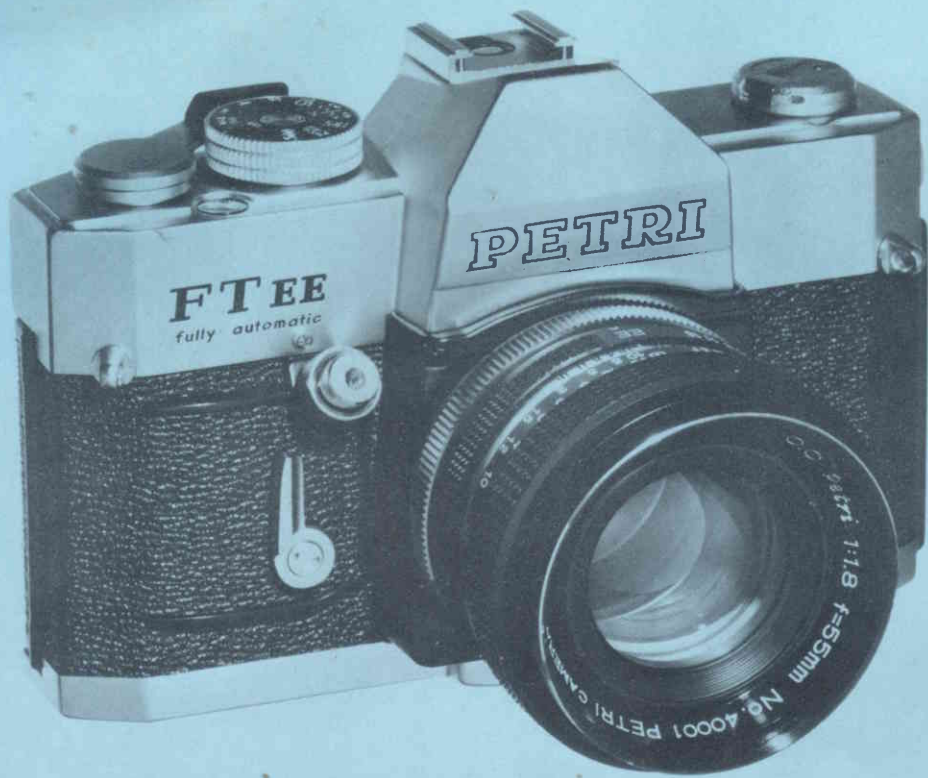

FTEE
fully automatic

PETRI

PETRI 1:1.8 f=55mm
No. 40001 PETRI CAMERA

MAJOR SPECIFICATION OF **PETRI F TEE**

TYPE:	Automatic EE camera with Pentaprism viewfinder and built-in cross coupled CdS exposure meter in open aperture Through-The-Lens metering system.
FILM:	35mm film (20, 36 or 12 exposures)
PICTURE:	24mm x 36mm
LENS:	Petri 55mm f/1.8, 6 elements in 4 groups, combination coated, with fully automatic diaphragm, aperture stops down to f/16.
SHUTTER:	Focal plane type with speeds of 1/2, 1/4, 1/8, 1/15, 1/30, 1/60, 1/125, 1/250 and 1/500 second and B. Built-in self-timer.
EXPOSURE SYSTEM:	Shutter speed pre-selected system. CdS exposure meter automatically measures optimum exposure conditions ranging from EV 3 to EV 17 with ASA 100 (DIN 21) film. Geared to the use of the normal lenses. Manual operation possible. ASA: 25 to 800 DIN: 15 to 30
VIEWFINDER:	Pentaprism viewfinder with Micromatic prism focusing device. The exposure meter needle and diaphragm number visible in the viewfinder. Under/Over exposure warning marks also visible.
FILM TRANSPORT:	Single stroke rapid film winding and shutter cocking
LENS MOUNT:	Petri bayonet lens mount
SYNCHRONIZATION:	FP and X automatic setting
FILTER SIZE:	52mm screw-in type
LENS HOOD SIZE:	54mm slip-on type
DIMENSIONS:	5.5 x 3.5 x 3.4 inches (142 x 93 x 88mm)
WEIGHT:	32 oz. (910 g.)
NOTE:	35mm and 135mm lenses, exclusively designed for the EE system, available.

INDEX

MAJOR SPECIFICATION OF PETRI FT EE . . .	2	EXPOSURE METER COUPLED RANGE	17
INDEX	3	SHOOTING AGAINST THE LIGHT	18
DESCRIPTION OF PARTS	4	VIEWFINDER AND FOCUSING	19
BATTERY FOR THE CdS EXPOSURE METER	7	DEPTH OF FIELD	20
FILM WIND LEVER	8	HOW TO READ THE DEPTH OF FIELD SCALE	20
EXPOSURE COUNTER	8	HOW TO HOLD YOUR PETRI FT EE CAMERA	22
FILM SPEED (ASA OR DIN) SETTING	9	FILM LOADING	23
SHUTTER SPEED DIAL	10	FILM UNLOADING	25
DIAPHRAGM SCALE (APERTURE SETTING)	11	HOW TO CHANGE YOUR LENS	26
FULLY AUTOMATIC EXPOSURE CONTROL IN THROUGH-THE-LENS SYSTEM	12	FLASH PHOTOGRAPHY	27
EXPOSURE WARNING MARKS	13	HOW TO USE BUILT-IN SELF-TIMER	29
MANUAL EXPOSURE CONTROL IN THROUGH-THE-LENS SYSTEM	15	INFRA-RED PHOTOGRAPHY	29
TO ADJUST THE EXPOSURE CONDITION	15	MAINTENANCE AND CARE OF YOUR PETRI FT EE	30
TO CHECK THE DEPTH OF FIELD	16	PETRI INTERCHANGEABLE LENSES	31
TO TAKE CLOSE-UPS	16	PETRI ACCESSORIES	33
TO USE NORMAL LENSES	16		

DESCRIPTION OF PARTS

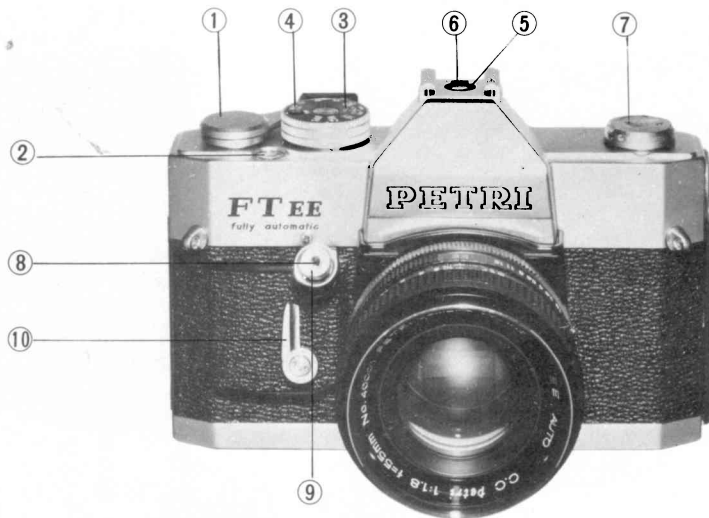

- | | | | | | |
|---|----------------------|---|------------------------|---|------------------------|
| ① | Film Advance Lever | ⑤ | Accessory Shoe | ⑨ | Shutter Release Button |
| ② | Film Counter | ⑥ | Cordless Flash Contact | ⑩ | Self-timer Lever |
| ③ | Shutter Speed Dial | ⑦ | Film Rewind Crank | | |
| ④ | Film Speed Indicator | ⑧ | Cable Release Socket | | |

DESCRIPTION OF PARTS

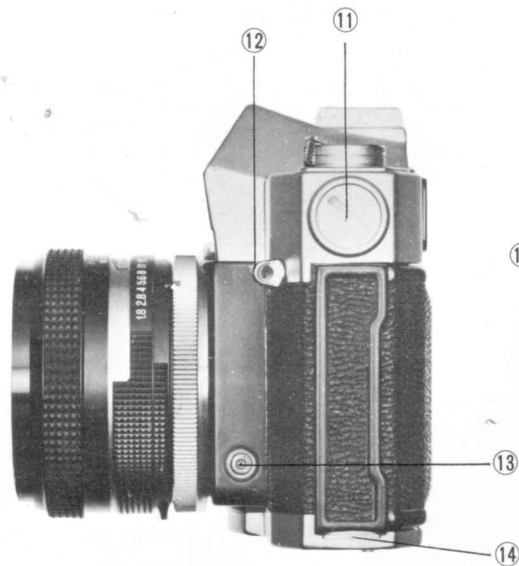

- ⑪ Battery Compartment
- ⑫ Neck Strap Loop
- ⑬ Flash Socket
- ⑭ Back Cover Lock



- ⑮ Distance Scale
- ⑯ Depth of Field Indicator
- ⑰ Diaphragm Scale
- ⑱ Diaphragm Pin
- ⑲ Aperture Control Pin

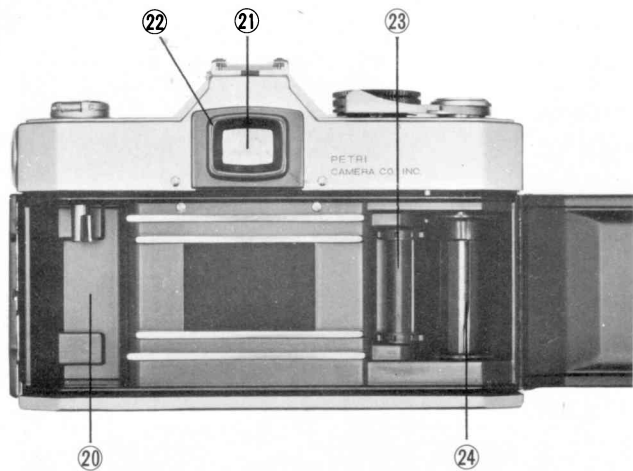

- ②① Film Cassette Chamber
- ②① Viewfinder
- ②② Viewfinder Frame
- ②③ Sprocket
- ②④ Take-up Spool

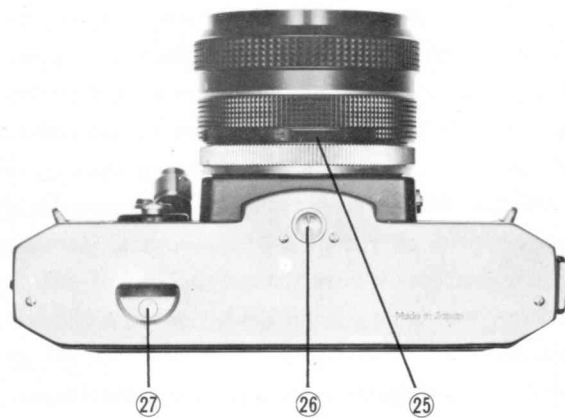

- ②⑤ Auto and Manual Diaphragm Lever
- ②⑥ Tripod Bush
- ②⑦ Film Rewind Button

BATTERY FOR THE CdS EXPOSURE METER

The built-in CdS exposure meter is powered with a 1.3 volt mercury battery (Mallory RM 675R, National M-1C, Toshiba TH-KC or equivalent). The battery compartment is located on the left-hand side of the top cover. The exposure meter is switched on by a stroke of the film advance lever. When the exposure meter needle does not respond to a change of light conditions, the battery has become exhausted and must be replaced.

Unscrew the battery compartment cover with your finger tips or a coin and insert a new battery with the plus (+) upward, facing the battery compartment cover, into the battery compartment.

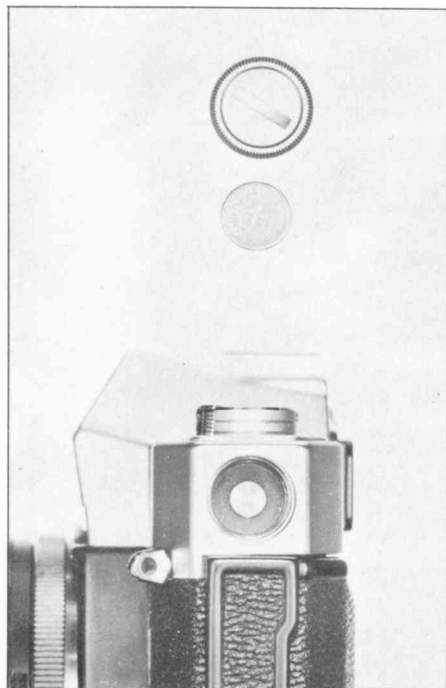



FILM WIND LEVER

When the film wind lever is advanced, the following things happen simultaneously:

1. The battery switch is turned on and the exposure meter is activated.
2. The film frame is transported to the next unexposed frame.
3. The film counter is advanced.
4. The shutter is cocked.

After the shutter is released, the battery circuit is shut off and unnecessary battery drain is avoided.

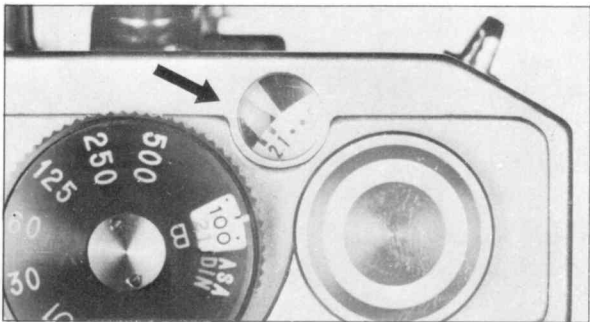

EXPOSURE COUNTER

The counter is located on top of the camera body. It shows the number of film frames exposed, and automatically resets to "S" (for "Start") position when the back cover is opened. Frames of the 20th and 36th are marked in red to signal end of the roll, depending on the length of the film used.

FILM SPEED (ASA OR DIN) SETTING

After the film has been loaded, be sure to set the ASA or DIN film speed index specified for the film in use on the film speed scale. This adjusts the exposure meter for the film being used and an essential step in getting properly exposed pictures.

To set the film speed, raise the external ring of shutter speed dial and turn to align the reading equivalent to speed of the film in use with the index mark. Do not set in between click-stops. If the reading does not align correctly, the ring will never drop down. The black numbers represent ASA values and range from ASA 25 to 800, and the red numbers represent DIN values ranging from DIN 15 to 30. Read the instructions supplied with the film and set the correct film speed index number. If the number of the film speed corresponding to that of your film is not available on the film speed scale, use the closest number and never set between two settings. For convenience, the positions for intermediate film speeds are shown only by dots. See the illustration.

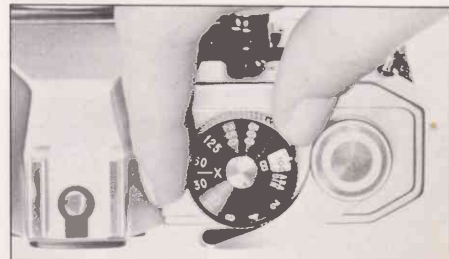
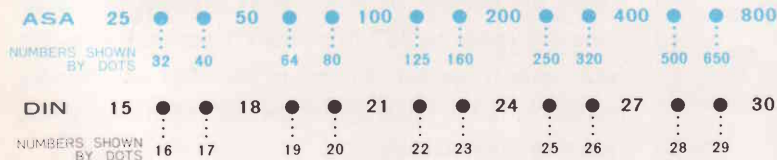

SHUTTER SPEED DIAL

B for manual operation only

B with flash with time

X with flash without time exposure

Your camera shutter has a range of speeds covering sufficiently all the ordinary picture situations. It has the settings of: 1/500, 1/250, 1/125, 1/60, 1/30, 1/15, 1/8, 1/4 and 1/2 second and Bulb. When the Bulb setting is used, the shutter stays open as long as the shutter button is being depressed (for time exposure).

The settings are represented on the shutter speed dial located right-hand on top of the camera body. For convenience, only the lower half of the numbers (250 for 1/250, etc.) and B (for Bulb) are etched on the black wheel. The shutter speed is set by lining up the appropriate number or B with the black line on the Pentaprism cover. Do not set the shutter speed between two click-stops.

The shutter speed can be selected either before or after the shutter has been cocked.

For indoor photography, it is recommended to set the shutter at 1/30 or 1/60; for outdoor photography, at 1/125 or 1/250; and for action photography such as in sports or snap shots it is important to use faster speeds of 1/250 or 1/500 to avoid blurring.

The number "15" for 1/15 second is larger than others and painted in fluorescent. When using the shutter speeds slower than 1/15 second, it is recommended to use a tripod and a cable release equipment so as to avoid camera shake.



DIAPHRAGM SCALE (APERTURE SETTING)

The diaphragm scale is located on upper side of the lens barrel and there is an "EE" mark in red letter on it. When the diaphragm is set at the "EE" mark, the camera automatically selects the optimum aperture opening corresponding to the amount of light entering the lens. The proper aperture opening the camera has selected is indicated by the needle in the viewfinder.

The aperture opening has seven settings, ranging from f/1.8, the maximum opening, to f/16, the minimum opening. For further information as to the diaphragm scale, see MANUAL EXPOSURE CONTROL IN THROUGH-THE-LENS SYSTEM (page 15).

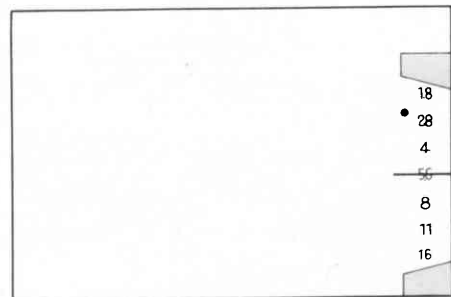

The proper f/number the camera selects is indicated in the viewfinder.

FULLY AUTOMATIC EXPOSURE CONTROL IN THROUGH-THE-LENS SYSTEM

OPEN APERTURE SYSTEM

The diaphragm in the EE photography operates as shown in the diagram.

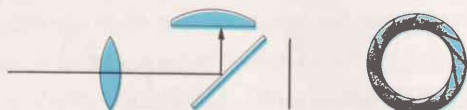

- (1) The exposure control is done with full aperture opening.

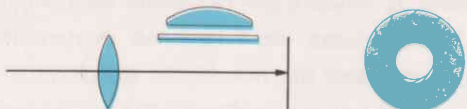

- (2) Just before the shutter operates, the diaphragm automatically stops down to the size the exposure meter has selected.

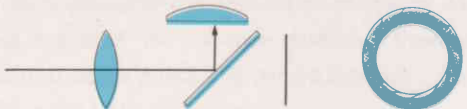

- (3) After exposure, it opens again and the battery circuit is shut off.

Set the aperture at "EE" mark in red letter on the diaphragm scale. This is all you have to do for exposure control. By setting the aperture at the "EE" mark, the auto and manual diaphragm lever is automatically switched to the "A" position (fully automatic operation) even in case it is being set at the "M" position in green (manual operation). Thus, the exposure control is done with the full aperture opening and the viewfinder is always seen bright for easy and accurate focusing. (This is called "Open Aperture System.")

The light entering Through-The-Lens strikes the two CdS cells located on each side at the base of the Pentaprism (see the diagram) and the CdS cells measure the average brightness of subjects you frame in the viewfinder. (This is what is called "Through-The-Lens metering system".)

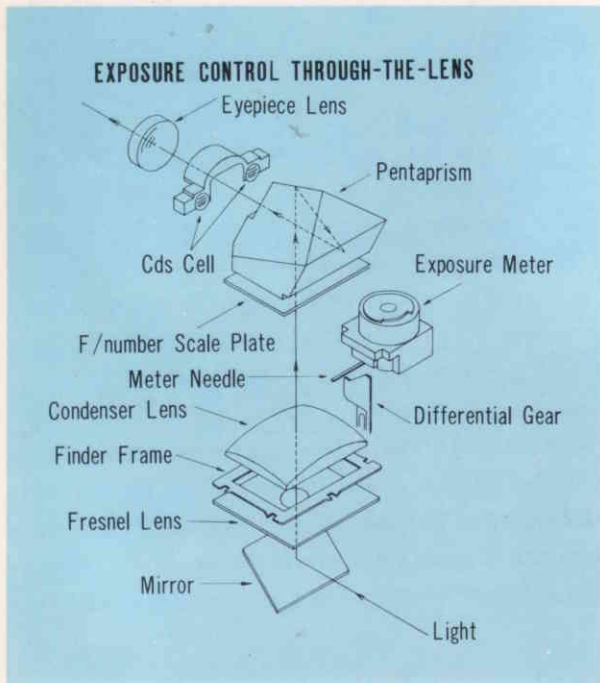

NOTE

- ① The B (bulb) setting is not usable in the Electric Eye photography. Switch the diaphragm to the manual operation and set the diaphragm by turning the diaphragm scale.
- ② The stopped-down light measuring is applicable to the 55mm standard Electric Eye lens, but not to other interchangeable Electric Eye lenses. *(shutter speed)*

EXPOSURE WARNING MARKS

In the viewfinder there is a diaphragm scale and on each end of the scale you will notice the red zone. The red mark above the f/16 is an over-exposure warning mark, and the one below the f/1.8 is an under-exposure warning mark.

(1) OVER-EXPOSURE

When the exposure meter needle swings down to the over-exposure warning mark, it shows "over-exposure". Set the shutter at a faster speed or use an appropriate filter to absorb the amount of light. (For the proper filter, see page 33.)

(2) UNDER-EXPOSURE

When the exposure meter needle jumps up to the under-exposure warning mark, it shows "under-exposure". Set the shutter at a slower speed. However, at the slower shutter speed than 1/15 second, it is recommended to use a tripod to avoid camera shake. When the meter needle won't come down to the diaphragm scale in the viewfinder, it shows that the amount of light entering the lens is extremely poor for the normal photography. Use flood illumination or switch to the flash photography (see FLASH PHOTOGRAPHY at page 27).

IMPORTANT

Make sure that the film speed is set at the correct reading specified for the film in use. (For further information, see FILM SPEED SETTING at page 9.) The automatic exposure control is not applied to the flash photography.

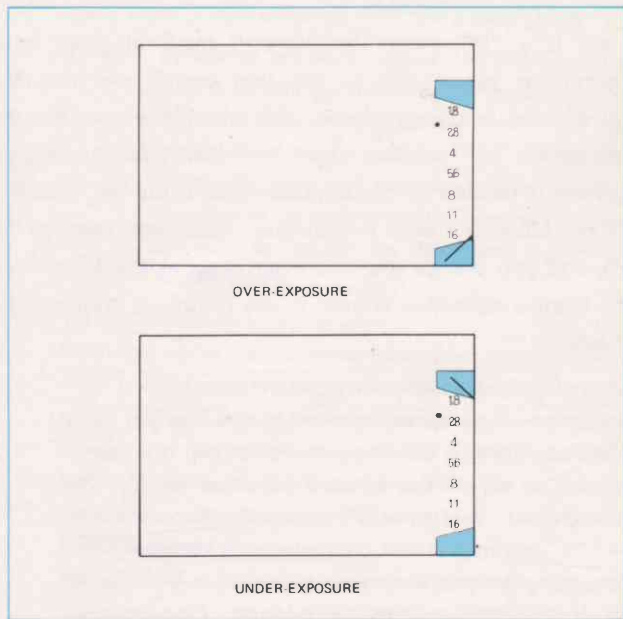

MANUAL EXPOSURE CONTROL IN THROUGH-LENS SYSTEM

use M for

Direct light or dark background - to adjust

read EE first

MANUAL EXPOSURE CONTROL IN THROUGH-LENS SYSTEM

There is a "M" (short for Manual) mark in green letter around the upper side of the lens barrel, and the auto and manual diaphragm lever ②⑤ which switches the diaphragm to "M" position from "A" (short for Automatic) position is located on the opposite side of the "M" and "A" marks. Move the auto and manual diaphragm lever to the left, and you will see the diaphragm is set at the "M" position. The manual operation is used in the following photographic situations:

TO ADJUST THE EXPOSURE CONDITION

When the main subject of the whole picture area you frame in the viewfinder is extremely dark or bright, it is recommended to adjust the exposure condition so that the important subject is correctly exposed. Set the exposure at the "EE" control and read the f/number in the viewfinder. Then, swing the auto and manual diaphragm lever to the left and set the diaphragm on the "M" position. If the important subject is comparatively dark, set the f/number at a half or

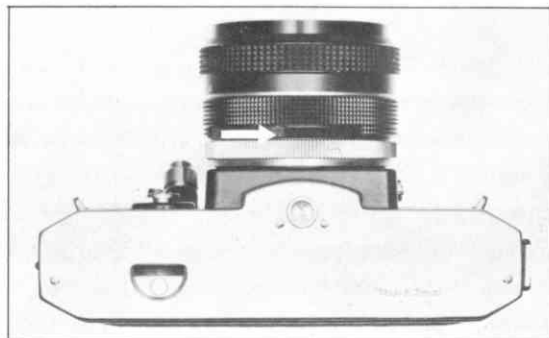

Move the lever and switch to the "M" position.

one stop closer to the full aperture than the f/number indicated in the viewfinder when you have set the exposure at the "EE" control. If the subject is brighter, set the f/number at a half or one stop closer to the minimum aperture than the f/number the "EE" control let you know. For example, when you take a portrait with a back-ground of snow scene or on the beach, you can get a properly exposed picture by using a half or one stop wider aperture opening than normal.

2 *Close-ups*

TO CHECK THE DEPTH OF FIELD

Setting the auto and manual diaphragm lever on the "M" position you can pre-view the depth of field and see in the viewfinder the lens zone of sharpness with any aperture.

TO TAKE CLOSE-UPS

3

When you use a close-up unit such as the extension tubes or the extension bellows, the automatic exposure control does not work. PETRI FT EE, however, has a means of obtaining a proper exposure setting.

1.8

~~2.8~~

4

5.6

8

11

16



Look through the viewfinder, and you will see a small blue dot very close to the f/2.8 in the diaphragm scale. This is the exposure indication mark. First, set the diaphragm on the "M" position and select an appropriate shutter speed.

Then, looking through the viewfinder swing the diaphragm ring as far as the meter needle comes on to the exposure indication mark in the diaphragm scale. Through these procedures you can get the optimum exposure setting. If the

meter needle stays above the mark, use a slower shutter speed, and if it stays under the mark, use a faster speed.

NOTE: In manual exposure control, the diaphragm ring should be swung between f/1.8, the largest aperture, and f/16, the smallest aperture. If you have inadvertently swung it to the "EE" mark on the diaphragm scale, the diaphragm is consequently switched to the position in the automatic exposure control. So, switch the diaphragm to the "M" position again.

4

TO USE NORMAL LENSES

When you use the normal lenses that are not designed for the "EE" photography, the automatic exposure control does not work. However, you can obtain the proper exposure reading through the procedures stated in TO TAKE CLOSE-UPS (page 16). As to the Petri interchangeable lenses designed for the "EE" photography, see PETRI INTERCHANGEABLE LENSES at page 31.

IMPORTANT Make sure that the film speed is set at the correct reading specified for the film in use. (For further information, see FILM SPEED SETTING at page 9.)

5 *flash*

EXPOSURE METER COUPLED RANGE

probably good for close-up + Bl + white (Values)

EXPOSURE METER COUPLED RANGE

PETRI FT EE has a fully coupled CdS exposure meter which measures optimum exposure conditions Through-The-Lens, ranging from EV 3 to EV 17 with ASA 100 (DIN 21) film.

HOW TO READ THE CHART

The word "EV" stands for "Exposure Value", which represents the brightness on the subject you frame in the viewfinder. The EV is represented by numbers, and the exposure meter of the PETRI FT EE can measure the brightness on the subject ranging from EV 3 to EV 17 when you use the film speeded at ASA 100 (DIN 21).

For example, if the exposure meter needle stays around f/5.6 with shutter speed of 1/125 second (the film speed dial is set at ASA 100) in the EE photography, the brightness on the subject is supposed EV 12. If the brightness is at EV 12, you can use every one of six different shutter speeds and get properly exposed pictures. If you change shutter

speed from 1/125 second to 1/250, one stop faster, the diaphragm is automatically altered from f/5.6 to f/4, one stop smaller aperture. Thus, you can use six different shutter speeds ranging from 1/500 second to 1/15 second (see the chart) when the EV is at 12. What shutter speed you should use depends on the condition of subject. (Refer to SHUTTER SPEED DIAL at page 10.) The diaphragm opening should be also decided according to the purpose of your photography. (Refer to DEPTH OF FIELD at page 20.)

Exposure Meter Coupled Range Chart
EV 3 - EV 18

ASA 100

f	EV 3	4	5	6	7	8	9	10	11	12	13	14	15	16	17
1.8	2	4	8	15	30	60	125	250	500						
2.8	1	2	4	8	15	30	60	125	250	500					
4		1	2	4	8	15	30	60	125	250	500				
5.6			1	2	4	8	15	30	60	125	250	500			
8				1	2	4	8	15	30	60	125	250	500		
11					1	2	4	8	15	30	60	125	250	500	
16						1	2	4	8	15	30	60	125	250	500

shutter speeds



Normal lighting



Back lighting

SHOOTING AGAINST THE LIGHT

When the light is available from the back of the subject and your main subject is comparatively darker than the back-ground, it is recommended to adjust the exposure condition. The procedure is same as required when the important subject is dark. (Refer to TO ADJUST THE EXPOSURE CONDITION at page 15.)

First, set the exposure in the EE photography and read the f/number in the viewfinder. Then, rotate the diaphragm ring to the right and set the f/number at a half or one stop closer to the full aperture than the f/number indicated in the viewfinder when you have set the exposure for the EE photography.

VIEWFINDER AND FOCUSING

PETRI FT EE has the original PETRI Micromatic Focusing system for fast and accurate focusing. The precision focusing elements in the viewfinder consist of a group of more than 800 micro-prisms as shown in the center of the picture.

As you look through the micro-prism area (A) in the viewfinder, you can see the subject clearly, ONLY when it is correctly focused. Rotating the focusing ring you will notice the appearance of something like a mesh of a net in the center of the viewfinder. This reticulation is caused by the flickering of reflected light entering the camera lens. When the subject is correctly focused the flickering grid fades away from the micro-prism area. In the second inner circle (B) is the plain glass area where the subject is always seen sharp and clear, even when the lens is out of focus. When the lens is correctly focused the image in the micro-prism area will be as sharp and clear as that seen in the surrounding circle (C).

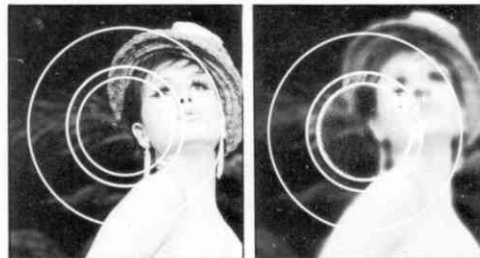
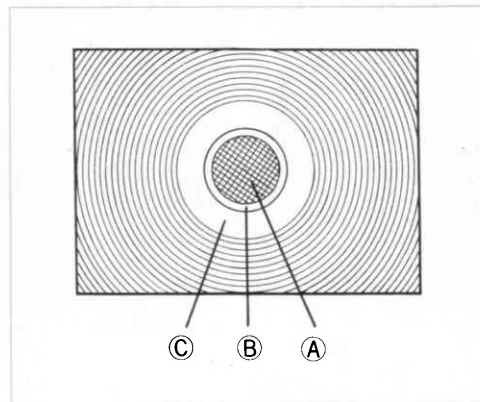

IN FOCUS

OUT OF FOCUS

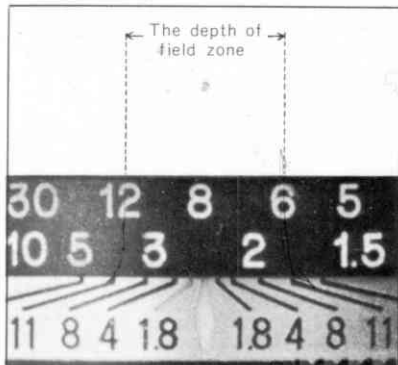

DEPTH OF FIELD

A lens that can be focused lets you accentuate the important image in a picture, while it can de-emphasize irrelevant objects in front of and behind the main subject by throwing them out of focus. This involves what is known as "Depth of Field". The smaller the aperture is the more the depth-of-field increases.

HOW TO READ THE DEPTH OF FIELD

The scale is engraved on the lens barrel of your camera and indicated in black lines spreading out both sides of the index marker at the center. Simply focus the lens in the normal way, and each pair of black lines which points to the diaphragm scale indicates the depth-of-field zone corresponding to the diaphragm you set.

For example, the depth-of-field zone for the standard 55mm lens is indicated as follows: When the focusing distance is 8 feet and the f/11 is selected, one of black lines at f/11 points to 6 feet, the nearest point still in focus, and the other points to approximately 12 feet on the other side, being the furthest distance in focus.

PETRI F/1.8 55mm DEPTH OF FTEL D TABLE

F No. Feet	1.8	2.8	4	5.6	8	11	16
∞	(feet) 158.55 ∞	(feet) 101.92 ∞	(feet) 71.35 ∞	(feet) 50.96 ∞	(feet) 35.67 ∞	(feet) 25.94 ∞	(feet) 17.84 ∞
30	25.25 36.95	23.21 42.41	21.16 51.54	18.93 72.30	16.34 182.74	13.96 ∞	11.23 ∞
12	11.17 12.97	10.75 13.57	10.29 14.38	9.74 15.62	9.01 17.94	8.24 22.04	7.22 35.56
8	7.62 8.41	7.43 8.66	7.21 8.98	6.94 9.45	6.56 10.24	6.15 11.45	5.56 14.24
6	5.79 6.23	5.68 6.36	5.55 6.53	5.39 6.77	5.16 7.17	4.90 7.73	4.52 8.90
5	4.85 5.16	4.77 5.25	4.68 5.36	4.57 5.52	4.41 5.78	4.22 6.14	3.94 6.85
4	3.91 4.10	3.86 4.16	3.80 4.23	3.72 4.32	3.61 4.48	3.49 4.69	3.29 5.09
3	2.95 3.05	2.92 3.09	2.89 3.12	2.84 3.18	2.78 3.26	2.71 3.37	2.59 3.56
2.5	2.46 2.54	2.44 2.56	2.42 2.58	2.39 2.62	2.35 2.67	2.30 2.75	2.21 2.87
2	1.98 2.02	1.96 2.04	1.95 2.05	1.93 2.07	1.90 2.11	1.88 2.15	1.82 2.23

The figures corresponding to 8 feet and f/11 are shown as 6.15 and 11.45, that is 6.15 feet, the nearest point in focus, and 11.45 feet, the furthest distance in focus.



HOW TO HOLD YOUR PETRI FT EE CAMERA

The format of your picture is determined by the position in which you hold the camera. Holding the widest part in a horizontal position will result in a horizontal format. Holding the widest part in a vertical position will result in a vertical format. Blurring in a picture often is caused by camera shake at the moment of exposure. Practice holding the camera and releasing the shutter so you can take pictures without jarring or shaking it.

Use the following three simple rules for taking a picture to avoid camera movement:

1. Before releasing the shutter, take a deep breath and hold it until after the picture has been taken.
2. While taking the picture, hold the camera firmly with both hands and press the back against your face and forehead as firmly as possible.
3. Squeeze the shutter release button, do not prod or tap it. Practice squeezing until you can release the shutter without the slightest quiver.

FILM LOADING

PETRI FT EE accepts the standard 35mm cartridges containing 12, 20 or 36-exposure lengths of film. Avoid direct sunlight falling on the film cartridge.

Load the film in a shade, using your body with your back to the sun as protection if you have no other method.



1. TO OPEN THE CAMERA BACK

Pull down the lever with your thumbnail and open the camera back. At the same time, the exposure counter automatically returns to "S" (which means "Start") position.

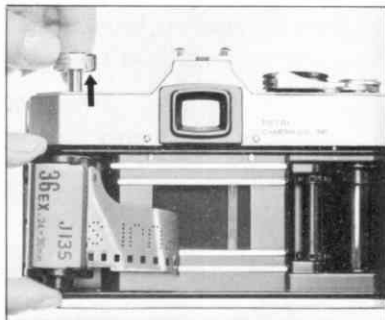

2. TO PULL OUT THE KNOB

Pull out the film rewind knob from top of the camera. This is to allow the film cassette to be put into the cassette chamber.

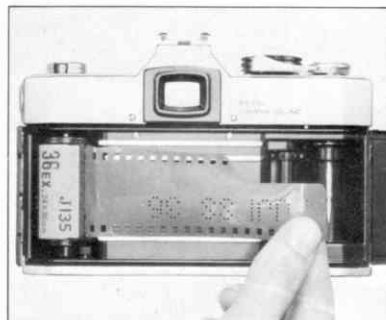

3. FILM LOADING

Slip the film end into any slit on the take-up spool and slide it down toward the bottom of the camera body, and check that the film perforation is properly engaged with the tooth of camera sprocket.

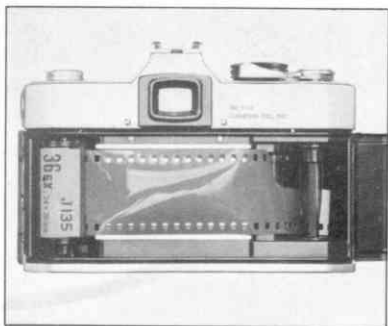

4. TO ADVANCE THE FILM

Advance the film advance lever a little and see that the film is fastened round the take-up spool, before closing the camera back.

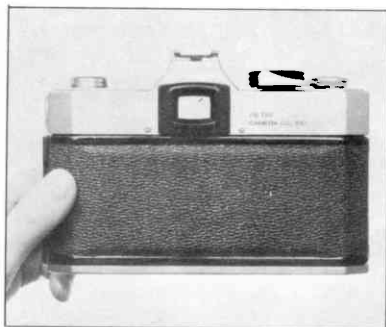

5. TO CLOSE THE CAMERA BACK

The camera back will be locked with a snap by a slight pressure.

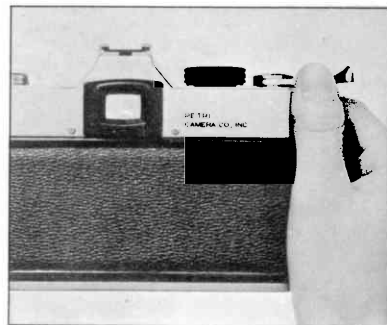

6. TO RELEASE THE SHUTTER AND ADVANCE THE FILM

Repeat this action twice, and you are ready to take your first picture.

NOTE: In case the film rewind knob does not turn counterclockwise by advancing the film advance lever, it shows that the film is not properly transported. Open the camera back and check the take-up spool.

FILM UNLOADING

After the entire length of film in the cartridge has been exposed, it must be

removed into the film cartridge so it can be removed from the camera.

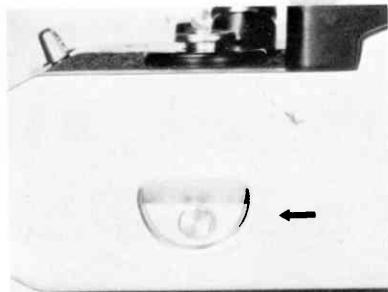

1. TO REWIND THE FILM

Depress the film rewind button located on bottom of the camera body. Raise the film rewind crank and turn it in the direction indicated by the arrow. You will feel a



little tension on the crank while the film is being rewound. When the tension stops, you know that the rewinding is complete.

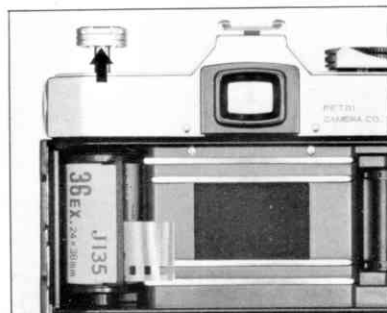

2. TO REMOVE THE CARTRIDGE

Pull out the film rewind knob and remove the film cartridge. Avoid direct sunlight when removing the film cartridge from the camera. Also, the camera lens should face downward while the cartridge is being removed so as to prevent it from dropping out.



HOW TO CHANGE YOUR LENS

(1) REMOVING THE LENS

Turn the Lens Mount Ring in a counterclockwise direction until the red mark appears on top of the lens barrel. The lens can then be removed from the camera.

(2) INSERTING THE LENS

Line up the red dot on the camera body with that on the lens mount ring. Then insert the lens making sure that the protruding lock on the bayonet mount of the lens is on the top. When the lens is in position, turn the lens mount ring tightly in a clockwise direction.

FLASH PHOTOGRAPHY

use X or B

When the exposure meter needle in the EE photography jumps up to the under-exposure warning mark (see page 14) and even a slower shutter speed can never make it come down to the diaphragm scale area, it shows that the lighting condition is too poor and that you must switch to flash photography.

Photography with flash not only extends your picture possibilities greatly but adds excitement and drama to your pictures. The use of flash equipment with your camera is relatively simple because it has built-in synchronization. It is equipped with X synchronization. (The shutter speed at "X" is 1/45 second.) Therefore, both electronic flash and ordinary single-exposure flashbulbs can be used.

PETRI FT EE is equipped with both a "hot shoe" contact for cordless unit and a standard PC terminal for one that has a cord. If you use a cordless unit, merely slip the foot of the unit into the shoe on top of the camera body and it will automatically make contact with the shutter mechanism. If the unit has a

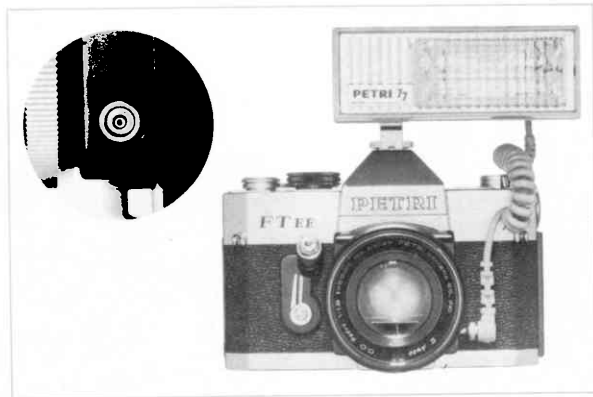

cord, simply plug the cord into the PC flash outlet. When using F class, M class and FP class flashbulbs, or an electronic flash unit, shutter speeds must be selected according to the table. (Speeds within the colored area are available.)

	1/500	1/250	1/125	1/60	X	1/30	1/15	1/8	1/4	1/2	B
FP	FP class (Screw mount)										
	FP class (Bayonett)										
X						F class bulb					
						M class bulb					
						Speed Light					

EXPOSURE CONTROL IN FLASH PHOTOGRAPHY

In flash photography the EE exposure control can not be used. The exposure depends on the shutter speed, the aperture opening, the film speed and the distance of the light from the subject, but if the shutter speed is constant and also the film speed is assumed to be constant, then the f/number required varies according to the lamp-to-subject distance. In another word, for any given shutter speed and film speed, the product of the aperture opening and the lamp-to-subject distance becomes a constant, and this constant is called the Guide Number. Thus, the f/number is calculated by the following formula:

$$\text{Guide Number} = \text{Distance} \times \text{f/number}$$

$$\text{f/number} = \frac{\text{Guide Number}}{\text{Distance}}$$

For example, in case a flashbulb of the FP class is used and the guide number corresponding to the ASA (or DIN) index and to the shutter speed selected is supposed to be 74, then the f/number, if the lamp-to-subject distance is 10 feet, will be about 8, because $74 \div 10 = 7.4 \approx 8$. No great accuracy is required in this calculation, and a quick mental division will give an f/number for any distance. In all cases, the nearest click-stop or 1/2 stop will be close enough for a practical work. The guide numbers are usually indicated on the packages of your flashbulbs or in the instruction manual of your strobo.

HOW TO USE BUILT-IN SELF-TIMER

Swing the self-timer lever in the direction indicated by the arrow as illustrated. Release the shutter button, and the frame will be exposed after a delay of approximately 9 seconds. The self-timer can be set at between positions (within the range of solid line) so as to shorten the release time and also be set either before or after advancing the film. All shutter speeds except B setting can be used with the self-timer.

The self-timer is usually used when the photographer wants to join a group which he is photographing. It is also useful for photomicrography or when using a long focal length lens. In all cases the use of a tripod is recommended.

INFRA-RED PHOTOGRAPHY

When taking infra-red pictures, reset the focusing distance to the red line indicated by the aperture f/1.8 on the Depth of Field Scale.

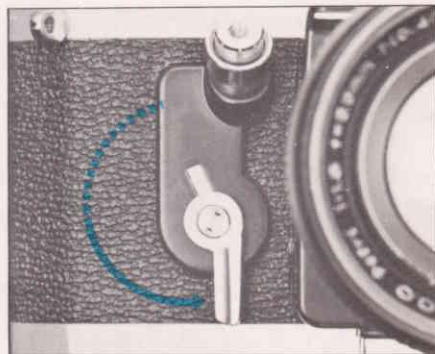

MAINTENANCE AND CARE OF YOUR PETRI FT EE

A few simple precautions, careful handling and immediate attention in case of trouble will prolong the life of your camera and keep it operating well indefinitely. Follow these simple rules:

1. When cleaning the outside of the camera, first use a soft brush and then a soft cloth.
 2. Remove dust and sand that enter the camera while it is open immediately, using a camel-hair brush or a hand-blower.
 3. Dust, fingerprints, water drops, etc., on the lens not only affect picture contrast but, if left for a long time, they will attack the surface.
 4. Should your camera fall into water, immediate attention is imperative. Bring it to a repair shop at once. If it falls into salt water, rinse it thoroughly in fresh water and then deliver it to the repairman.
 5. Your camera, when not in use, should be protected from damp and dust. Preferably in its case and, as an additional precaution, inserted into a polythene bag.
 6. Be sure that your camera is not kept in abnormally high or low temperatures — normal room temperature is best.
 7. Before storage, release the shutter and relieve a tension of every apparatus. When you store your camera for a prolonged period, remove a battery and avoid a risk of deterioration and corrosion.
 8. Do not leave your camera without use for a long period. Your camera, as any other mechanical instrument, needs to be exercised regularly to keep it in good condition. Set the shutter release and fire, turn to a slow shutter speed and again set the shutter release and fire. Also, operate the self-timer. Examine the exposure meter for correct operation. Check film transport. Check the Pentaprism viewfinder.
- These actions will keep the mechanism in good order, retaining the natural qualities of the lubricant — thus ensuring your camera is ready for an instant use when required.

PETRI INTERCHANGEABLE LENSES

PETRI FT EE accepts a wide range of Petri interchangeable lenses from 28mm wide angle to 1000mm telephoto, unparalleled in quality and design. The built-in CdS meter is geared to these interchangeable lenses which include Petri's original Periscope telephoto lens. Petri 35mm f/3.5 and 135mm f/3.8 both with the automatic diaphragm, specially designed for PETRI FT EE, allow the automatic exposure control and therefore, specify these lenses when you buy the 35mm and 135mm focal length lenses. Other interchangeable lenses are not fully coupled to the EE system. (As to the exposure control for the normal lenses, see TO USE NORMAL LENSES at page 16.)



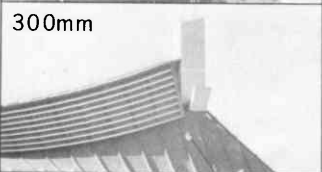
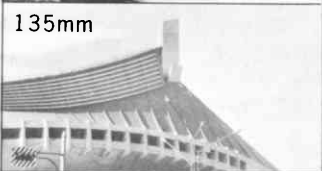
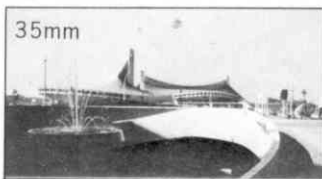

- 28mm f/3.5 wide angle with automatic diaphragm
- 35mm f/2.8 wide angle with automatic diaphragm, special design for the FT EE
- 100mm f/4.5 Periscope telephoto with preset diaphragm
- 135mm f/3.5 telephoto with automatic diaphragm
- 135mm f/3.8 telephoto with automatic diaphragm, special design for the FT EE
- 200mm f/4 telephoto with automatic diaphragm
- 300mm f/5.5 telephoto with preset diaphragm
- 400mm f/6.3 telephoto with preset diaphragm
- 500mm f/5.6 telephoto with preset diaphragm
- 1000mm f/8 telephoto with preset diaphragm
- 80 ~ 200mm f/4.5 Zoom with automatic diaphragm
- 85 ~ 210mm f/4.8 Zoom with preset diaphragm

PETRI ACCESSORIES

A complete range of filters, lens hood and other attachments such as extension tubes, bellows, eye-cups, etc. are available to meet any photographic situation. Through-The-Lens exposure system equipped in your PETRI FT EE gives the optimum exposure reading even when using filters, close-up units or in photomicrography.

FILTERS

Essential for first class photographs. Select the proper filters for your needs.

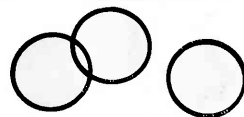

For Black & White Film:

FILTER TYPE	FILTER FACTOR	COLOR	PURPOSE
Y1	1.5X	Light Yellow	Landscapes, snow, clouds. Renders yellow and green lighter. Gives stronger effect than Y1.
Y2	2 X	Medium Yellow	
YA3	4 X	Orange	Haze distant views. Renders yellow and red lighter, blue darker, distant objects clearer.
R1	8 X	Red	Hazy distant views. Renders red lighter, blue and green darker. Gives stronger effect than orange filter.
PO0	2.5X	Green	Landscapes, snow, clouds. Renders green lighter. Red (complexion) and blue darker. Recommendable for portraiture.
PO1	4 X	Medium Green	Gives stronger effect than PO0.

For Color Film:

FILTER TYPE	FILTER FACTOR	COLOR	PURPOSE
UV	no increase	Clear	Absorbs excessive UV. Also suitable for black-and-white.
1A	no increase	Light Pink	To eliminate haze and for use at altitudes over 3,000 ft.
W4	1.5X	Medium Amber	Reduces excessive blueness of sky on a cloudy day.
C4	1.5X	Medium Blue	For early morning or evening shots.
C8	2 X	Dark Blue	Conversion filter for use when using 'Daylight Type' color reversal film with white flash bulbs.
C12	2.5X	Dark Blue	Conversion filter for use when using 'Daylight Type' color film with photoflood lamps.
85C	no increase	Dark Amber	Conversion filter for use when using 'Artificial Light' film in daylight.
NDX4	4 X	Neutral Density	Neutral Density for sunny subjects. Can also be used for black-and-white.

*Just ASA 100
Bl + white page 17*

EH 135 color slides



LENS HOOD



2X TELE-CONVERTER

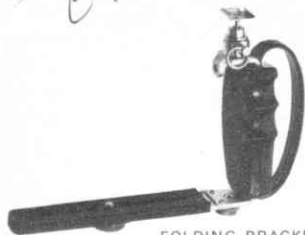

FOLDING BRACKET

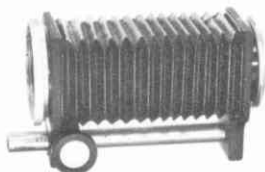

EXTENSION BELLOWS



EXTENSION TUBE SET



RIGHT
ANGLE
FINDER



EYE CUP



CABLE RELEASE

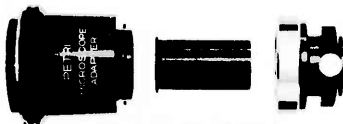

MICROSCOPE ADAPTER

*first roll
prints CX 135-36
Kodakolor X
ASA 80*