



This manual is for reference and historical purposes, all rights reserved.

**This page is copyright© by M. Butkus, NJ.**

This page may not be sold or distributed without the expressed permission of the producer

I have no connection with any camera company

On-line camera manual library

This is the full text and images from the manual. This may take 3 full minutes for the PDF file to download.

**If you find this manual useful, how about a donation of \$3 to: M. Butkus, 29 Lake Ave., High Bridge, NJ 08829-1701 and send your e-mail address so I can thank you. Most other places would charge you \$7.50 for a electronic copy or \$18.00 for a hard to read Xerox copy.**

**This will allow me to continue to buy new manuals and pay their shipping costs.**

**It'll make you feel better, won't it?**

**If you use Pay Pal or wish to use your credit card,  
click on the secure site on my main page.**

Sears

KSX/35MM SLR CAMERA  
INSTRUCTIONS

SLR  
CAMERA

KSX

## CONTENTS

Description of parts .....	2
Specifications .....	4
1. Inserting the batteries .....	7
2. Loading the film .....	8
3. Setting the film speed .....	11
4. Selecting the shutter speed .....	13
5. Meter/shutter "on-off" control .....	15
6. Setting the aperture .....	16
7. The correct exposure .....	17
8. Viewing and focusing .....	23
9. Depth of field .....	24
10. Infrared photography .....	25
11. Holding the camera .....	26
12. Changing lenses .....	27
13. Using self-timer .....	29
14. Viewfinder eyepiece cap .....	30
15. Using auto winder .....	30
16. Unloading film .....	31
17. Flash photography .....	32
18. Trouble shooting your camera .....	34
19. Proper care of your camera .....	36

# CONGRATULATIONS!

You have just purchased a fine camera that will give you many years of picture-taking pleasure. The KSX is a 35 mm SLR camera which assures you of superb optics, outstanding mechanical performance and reliability which will justify your choice for years to come.

## **Before using your KSX .....**

Please read this instruction booklet carefully and familiarize yourself with the equipment and its features thoroughly. Your pleasure in using your KSX will be greater if you know your camera properly.

# DESCRIPTION OF PARTS

1. Film Rewind Knob/Back Cover Lock Release Knob
2. Film Rewind Crank
3. Film Speed Dial (ASA)/  
Exposure Compensation Dial
4. Film Speed Lock Button
5. Flash Ready Signal Contact
6. Hot Shoe/Flash Contact
7. Shutter Speed Index Line
8. Shutter Speed Dial
9. Automatic Exposure Lock Button
10. Cable Release Socket
11. Shutter Release Button
12. Shutter "ON-OFF" Index Mark
13. Film Advance Lever
14. Exposure Counter
15. Neck Strap Eyelet
16. Self-timer Lever
17. Lens Release Lever
18. Lens Locator Node
19. Focusing Ring
20. Distance Scale
21. Depth of Field Scale
22. F-Stop Ring
23. Sprocket Teeth

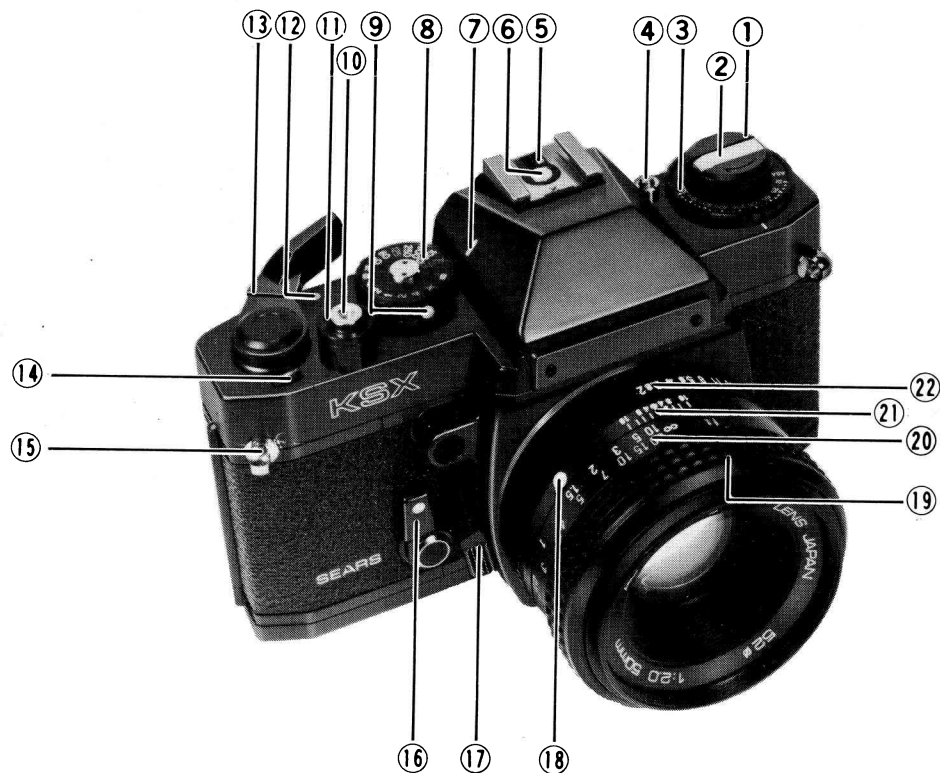

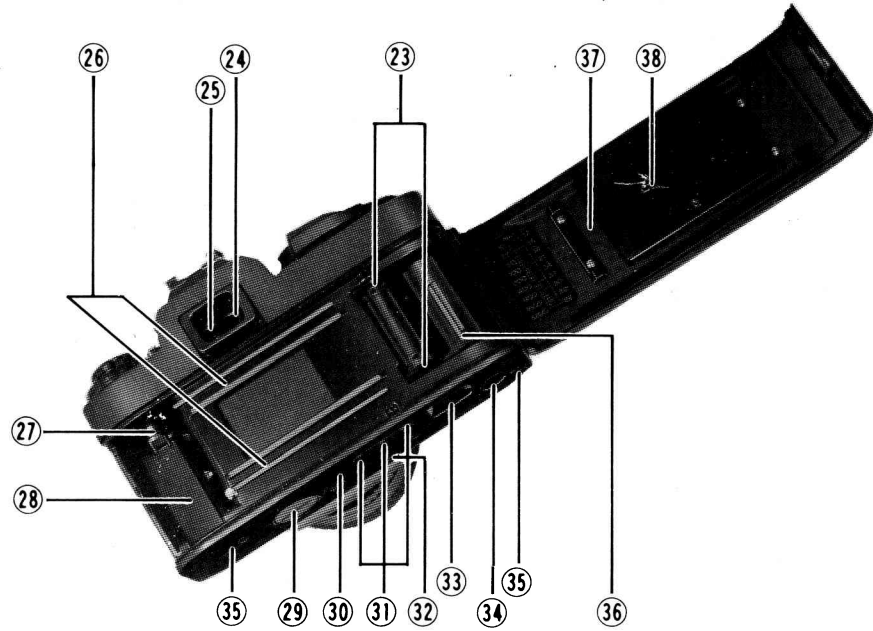
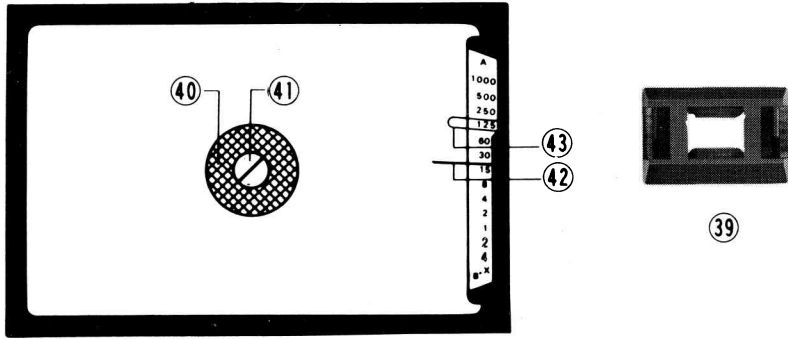

- 24. Viewfinder Eyepiece
- 25. Flash LED
- 26. Film Rail
- 27. Film Rewind Shaft
- 28. Film Chamber
- 29. Battery Compartment Cover
- 30. Tripod Socket
- 31. Winder Contacts
- 32. Shutter Release Connection
- 33. Film Rewind Release Button
- 34. Winder Coupler
- 35. Positioning Hole
- 36. Film Take-up Spool
- 37. Back Cover
- 38. Film Pressure Plate
- 39. Viewfinder Eyepiece Cap
- 40. Microprism-image Band
- 41. Split-image Spot
- 42. Exposure Meter Needle
- 43. Shutter Speed Indicator

# SPECIFICATIONS: Sears KSX

<b>CAMERA TYPE</b> .....	35 mm aperture-priority AE (automatic exposure) SLR with electronic metal focal plane shutter
<b>FILM FORMAT</b> .....	24 × 36 mm
<b>FILM SIZE AND CAPACITY</b> .....	35 mm perforated film in 12, 20, 24 or 36 exposures
<b>STANDARD LENS</b> .....	50 mm Auto Sears f/2.0, 5 groups, 6 elements Filter size: 52 mm screw-in type
<b>LENS MOUNT</b> .....	"K" type bayonet with 65° rotating angle
<b>SHUTTER</b> .....	Vertically moving Copal CCS-E electronically controlled metal focal plane shutter Automatic electronic shutter: continuously variable speeds from LT (approx. 8 sec.) to 1/1000 sec. Manual electronic shutter: stepped speed from 4 to 1/1000 sec. Manual mechanical shutter without batteries: "B" and "X" (1/90 sec.)
<b>VIEWFINDER</b> .....	Fixed eye-level pentaprism, shutter speeds, "A" (automatic), "B" (bulb), "X" (1/90 sec.), exposure meter needle, shutter speed indicator. Viewing magnification 0.83X Field of view covers 93% of actual picture area Flash ready lamp (LED)

<b>FOCUSING</b> .....	Diagonal split-image spot in microprism band surrounded by Fresnel field
<b>EXPOSURE METER</b> .....	Three CdS photocells TTL full open metering for center-weighted average light reading coupled to aperture-priority automatic exposure system
<b>EXPOSURE COUPLING RANGE</b> .....	EV 3 to 17 (ASA 100 film with 50 mm f/2.0 lens)
<b>FILM SPEED RANGE</b> .....	ASA 12 to 3200 (DIN 12 to 36)
<b>EXPOSURE METER POWER SUPPLY</b> .....	Two 1.5V silver-oxide batteries (Mallory MS76, Eveready S76 or equivalent)
<b>FLASH SYNCHRONIZATION</b> .....	X synchronization for electronic flash unit at "B", "X" (1/90 sec.) and 4 sec. to 1/125 sec.
<b>AUTOMATIC FLASH CONTROL</b> .....	With Sears 8025 Auto Flash, set shutter speed dial at Auto and it will set shutter speed 1/90 sec. automatically. Manually set the aperture ring to the same aperture set on flash.
<b>FLASH TERMINAL</b> .....	"X" contact (with electric shock prevention mechanism) on hot shoe for cordless electronic flash unit
<b>FILM LOADING</b> .....	Multi-slit easy loading
<b>FILM WIND</b> .....	Single stroke film advance lever with 135° winding angle (40° play) Automatic winding possible by mounting Sears KS Autowinder

<b>FILM REWIND</b> .....	Engage film rewind by pressing film rewind button on base of camera
<b>EXPOSURE COUNTER</b> .....	Additive, automatic resetting
<b>OTHER FEATURES</b> .....	Self-timer Hot shoe Shutter release lock (with film advance lever) Meter on/off switch (with shutter release button) ASA dial lock Cable release socket Tripod socket Plus/minus 2-stop exposure compensation dial (+2, +1, 0, -1, -2) View finder eye-piece cap ASA/DIN conversion label (on back of back cover) Automatic exposure lock button
<b>DIMENSIONS</b> .....	(Body only) Width: 139.9 mm (5.51 inches) Height: 91.3 mm (3.59 inches) Thickness: 48.0 mm (1.89 inches)
<b>WEIGHT</b> .....	(Body only) 545 g (19.25 oz)

# 1. INSERTING THE BATTERIES

Remove battery compartment cover by unscrewing it counter-clockwise with a coin.

Place two batteries into the compartment with the plus ⊕ side down, as illustrated in the battery holder of battery compartment cover. Make sure that the batteries are correctly placed. If incorrectly placed, the exposure meter needle in the viewfinder will not move at all. Replace battery compartment cover by screwing it clockwise until it stops, but do not force.

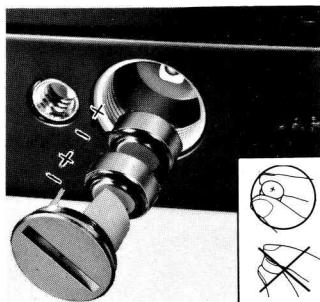

## Tips for Better Results:

- ★ Before loading, wipe off the surfaces of the batteries with a clean and dry cloth to ensure they are free of fingerprints or stains.
- ★ Shutter release button can be pressed without batteries. However, the shutter will not open and the mirror will stay up. To put the mirror back to its proper position, turn the shutter speed dial to "X" or "B". If you wish to take picture without batteries, use "X" (1/90 sec.) or "B".
- ★ When your camera is not used for a long period, remove the batteries and keep them in a cool, dry place.
- ★ Replace the batteries about once a year.
- ★ Do not dispose of batteries in fire—they may explode.

## 2. LOADING THE FILM

Pull up film rewind knob until back cover snaps open. Then, pull it out all the way to allow for insertion of the film cartridge. Swing open back cover and place a film cartridge into film chamber.

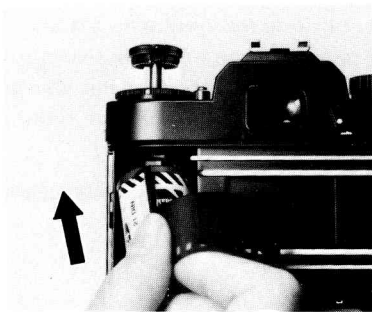
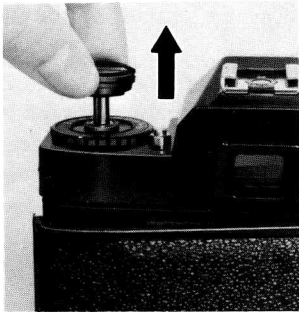



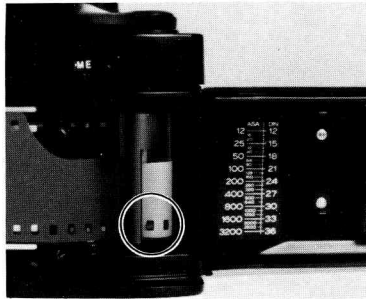

Rotate film take-up spool by advancing film advance lever to take up any slack in the film. Be sure film tip is firmly hooked onto film take-up spool and that the holes on both sides of the film are caught by the teeth on the film transport sprockets.

**NOTE:** The film must pass under the take-up spool when advanced.

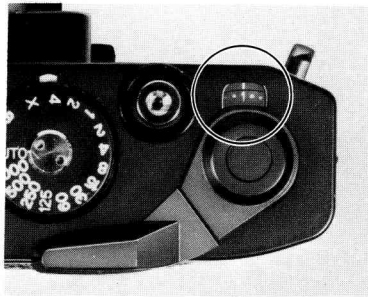

Close and press back cover firmly until it snaps shut. Advance film advance lever two or three times, after depressing shutter release button each time, until the number "1" is opposite in the index line in exposure counter. As you advance film advance lever, film rewind knob will simultaneously rotate counterclockwise indicating that the film is properly advanced. Your camera is now ready to go.

#### **Tips for Better Results:**

- ★ Always load your camera in the shade or in a poorly-lit place. Never in direct sunlight or other bright light.
- ★ When making blank exposures with shutter speed dial set at "AUTO", set f-stop ring to the smallest f-stop (the largest lens opening) so that you can make next blank exposure quickly. Otherwise a slower shutter speed will be the result.

### 3. SETTING THE FILM SPEED

Each type of film, color or black and white, has its own sensitivity to light. This sensitivity is assigned by a numerical value described as a ASA rating (U.S.A. Standard) or a DIN rating (Europe and most other countries). In most cases, both ASA and DIN ratings are imprinted on the film cartridge itself. The higher the film speed rating, the more sensitive the film is to light; that is, less light is required for a proper exposure. The film speed, therefore, is an important element in insuring that the through-the-lens metering system of your camera determines the correct shutter speed and f-stop combinations for a given lighting situation.

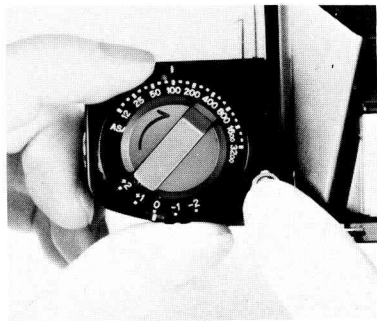

Depress film speed lock button and rotate the outer ring of film speed dial until the ASA (or DIN) number of your film is exactly opposite the index line on the outer ring of film speed dial and click stops. For example, if the film is ASA 100, make the correct setting at "100". Take your finger off film speed lock button to lock the film setting in the camera. The scale representing the relation between ASA and DIN numbers is illustrated on the inside of back cover.

### Tips for Better Results:

- ★ Each time a film with a new film speed rating is loaded in your camera, the film speed must be set to assure accurately exposed photographs.

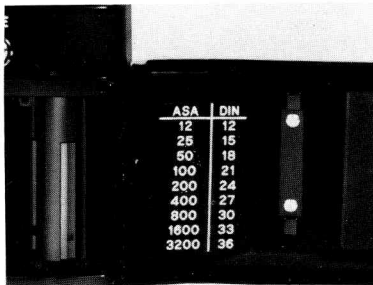
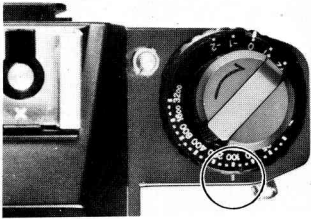

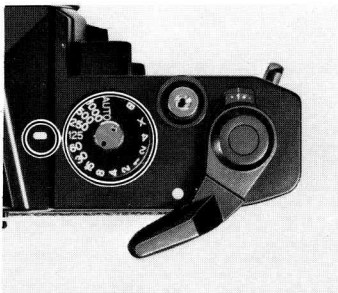

## 4. SELECTING THE SHUTTER SPEED

The shutter controls the length of time the light is allowed to strike the film. The speed at which the shutter opens and closes is measured in fractions of a second that correspond to the numbers on shutter speed dial. For example, "1000" is 1/1000 sec., "125" is 1/125 sec., "4" is 1/4 sec., "1" is one full second and so on. The "2" and "4" marked in yellow green stands for two and four seconds respectively. In automatic exposure operation, the correct shutter speed is set automatically. For manual exposure operation, simply turn shutter speed dial until the desired shutter speed is set opposite shutter speed index line.

To operate shutter speed automatically, set shutter speed dial on "AUTO" setting. Press the automatic exposure lock button to disengage dial lock when changing from "AUTO" to a desired shutter speed.

When selecting your own shutter speeds, we suggest the following: When shooting outdoors in bright or hazy sunlight, "125" (1/125 sec.) is suitable for most pictures. When taking your subjects in motion "250" (1/250 sec.) to "1000" (1/1000 sec.) should be used ..... faster speed will "freeze" extremely fast moving subjects (sports, racing cars, etc.). When indoors in a well-lit room, "60" (1/60 sec.) should be sufficient to take your subject, depending upon the film you are using. When in poorly-lit places, or to achieve the maximum depth of field, "30" (1/30 sec.) to "1" (1 sec.) should be used. When

set at "B", the shutter will remain open as long as shutter release button is depressed (preferably by a cable release). The "B" setting is used for long night exposures using street lights or electric signs as a light source, or under poor lighting conditions when flash cannot be used. When set at "X", the shutter operates at 1/90 sec. This setting is used when the batteries don't have sufficient power or when you are taking pictures without batteries. Flash photography is also possible at this setting.

#### **Tips for Better Results:**

- ★ When using slow speeds (below 1/30 sec.) and "B" setting, use a tripod and cable release to minimize camera movement and prevent blurred pictures. Be especially careful to minimize camera movement when using a telephoto lens.
- ★ When shutter speed dial is set at "B" or "X", set the desired f-stop and expose manually because metering with the built-in exposure meter is not possible.
- ★ Do not set shutter speed dial between marked speeds, but only at a click stop in accordance with indicated speeds.
- ★ Shutter speed dial does not revolve between "AUTO" and "B".

## 5. METER/SHUTTER "ON-OFF" CONTROL

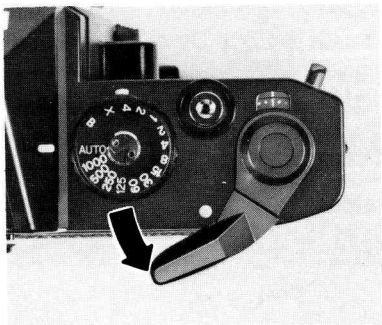

Film advance lever controls exposure meter "ON-OFF" and shutter release "LOCK-UNLOCK" to protect your camera from unnecessary depletion of the batteries and accidental shutter release when not taking pictures. 40° pre-advance with two click positions in 20° and 40° angle and 135° advance angle assure faster winding and permits continuous operation for sequence photography. Choose your suitable angle of 20° or 40° pre-advance position.

When film advance lever is moved to "ON" position, the electric circuit is switched on and shutter release button is unlocked.

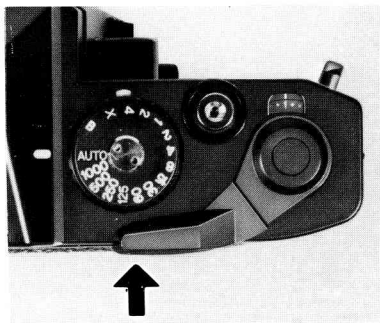

Whenever picture-taking is complete, be sure to move film advance lever to "OFF" position. The electric circuit is switched off and shutter release button is locked.

## 6. SETTING THE APERTURE

The lens opening determines the amount of light entering the lens and exposing the film. The smaller the f-stop (f/2.0, f/2.8, etc.) the wider the lens opening and the greater the amount of light entering the lens. The larger the f-stop (f/16, f/11, etc.), the smaller the lens opening and the smaller the amount of light entering the lens. As the lens opening is moved from f/16 to f/11, the amount of light entering the lens is doubled. As the lens opening is moved from f/2.0 to f/2.8 the amount of entering light is cut in half.

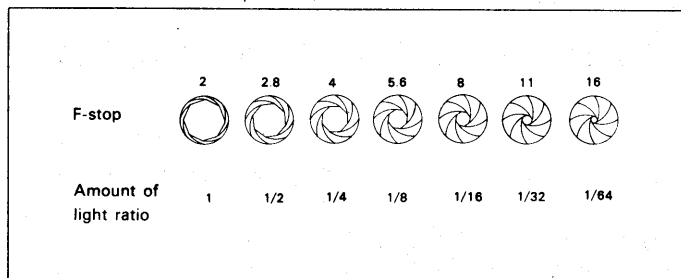

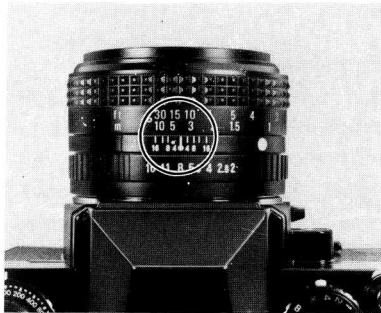

Rotate f-stop ring until the desired f-stop is opposite the aperture index line. Click stops are provided to prevent accidental movement from the setting made. If necessary, you may set f-stop ring between two f-stops.

## 7. THE CORRECT EXPOSURE

### Automatic Exposure:

Your KSX has a built-in through-the-lens full aperture CdS exposure meter coupled to aperture-priority automatic exposure control system which selects and sets correct shutter speed automatically for correct exposure.

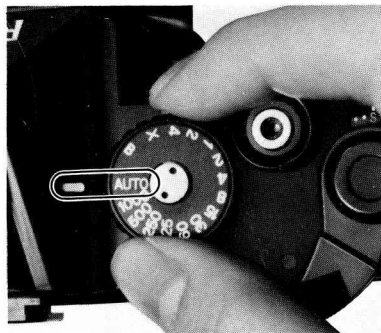

Turn shutter speed dial until the "AUTO" is set opposite shutter speed index line. Shutter speed indicator in the viewfinder indicates "A", showing that the camera is set for automatic exposure control.

For pre-selecting the aperture, refer to the following rough guide when using ASA 100 film:

Outdoors in bright sunlight .....	f/8.0 to f/16
Cloudy weather or in shade .....	f/2.8 to f/5.6
Indoors .....	f/1.4 to f/4.0

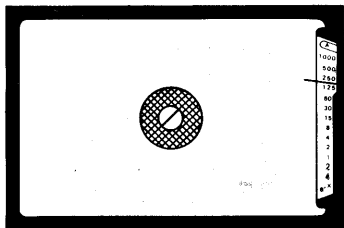

Now you should check the exposure before shooting. After moving film advance lever to "ON" position, press shutter release button lightly half way down until the exposure meter needle begins to move. The exposure meter needle in the viewfinder indicates the shutter speed you will be shooting at. If the needle goes above "1000", close down the aperture until the needle moves below "1000". If the needle goes below "B.X", open up the aperture until the needle moves above "B.X".

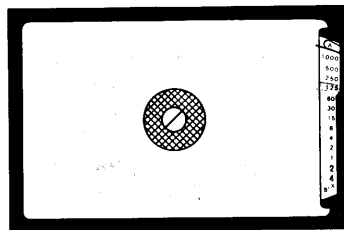

#### Tips for Better Results:

- ★ At slow speeds (below 1/30 sec.), use tripod or other firm support to prevent camera movement and blurred pictures. In shooting with a telephoto lens, be careful to minimize the camera shake in particular. When using telephoto lenses, a good rule of thumb is "use a shutter speed faster than 1/focal length of the lens". For example, with a 135 mm lens, use a shutter speed faster than 1/125 sec. Otherwise a tripod is suggested.
- ★ The shutter speed is automatically determined at any speed within the range of approximately 8 sec. to 1/1000 sec., according to the lighting conditions of your subject.

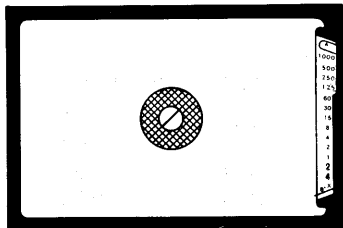

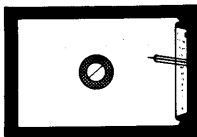

Correct exposure

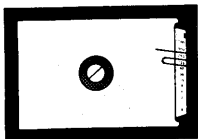

Over-exposure



Under-exposure

### Manual Exposure:

The through-the-lens full aperture CdS exposure meter measures the light coming through the lens and enables you to set the proper exposure for a given lighting condition. The correct exposure is obtained by setting the shutter speed and f-stop (aperture) in the correct combination for the film subject and lighting conditions.

Press automatic exposure lock button and move shutter speed dial off "AUTO". Set the desired shutter speed opposite shutter speed index line by rotating shutter speed dial (Read "SELECTING THE SHUTTER SPEED"). Shutter speed indicator in the viewfinder indicates the shutter speed you just set.

Move film advance lever to "ON" position.

Hold your camera, look at your subject through viewfinder eyepiece, press shutter release button lightly halfway down and check exposure meter needle.

Rotate f-stop (lens opening) ring and align exposure meter needle with shutter speed indicator. If exposure meter needle goes above shutter speed indicator, this means "over-exposure"; select a faster shutter speed or a small lens opening. On the contrary, if the needle goes below shutter speed indicator, this means "under-exposure"; choose a slower shutter or a larger lens opening.

If you want to use a specific f-stop for depth of field control, you may set the f-stop first and then the shutter speed, while other procedures are the same as previously. How your subject turns out in the picture depending on the f-stop setting (Refer to "DEPTH OF FIELD").

#### **Exposure Compensation Dial for Automatic Exposure:**

The dial is used when exposure compensation (intentional over- or under-exposure) is necessary in automatic exposure operation. In unusual lighting conditions, for both automatic and manual exposure, the desired effect or the correct exposure will not be obtained in the final picture and exposure compensation is necessary.

Lift up the outer ring of exposure compensation dial and rotate it until the index line on the ring is opposite the corresponding number you desire (+2, +1, -1, -2) and click stops.

#### **Back-lit Subjects (when light is behind the subjects):**

Set the dial at +1 or +2.

#### **Spot-lighted Subjects and Dark Backgrounds:**

Set the dial at -1 or -2.

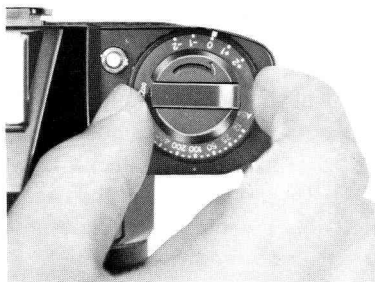

### **Tips for Better Results:**

- ★ When exposure compensation is unnecessary, be sure to set exposure compensation dial at "0".
- ★ Do not set exposure compensation dial between marked numbers, but at a click stop in accordance with indicated numbers only.

### **Exposure Compensation for Manual Exposure:**

#### **Back-lit Subjects (when light is behind the subjects):**

1. Move close to the subject for meter reading, then, move back, focus and shoot.
2. If it is impossible to approach the subject, adjust either shutter speed or lens opening to over-exposure. When you adjust the lens opening, open up the aperture by 1 or 2 stops.

#### **Spot-lighted Subjects and Dark Backgrounds:**

1. Move close to the subject for meter reading, then move back, focus and shoot.
2. If it is impossible to approach the subject, adjust either shutter speed or lens opening to under-exposure. When you adjust the lens opening, close down the aperture by 1 or 2 stops.

### **Tips for Better Results:**

- ★ When the shutter speed dial is set at "B", set the desired f-stop and expose manually because metering with the built-in exposure meter is not possible.

## 8. VIEWING AND FOCUSING

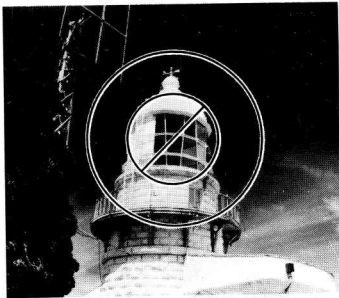

In focus



Out of focus

Since you are viewing through the lens, there is no parallax problem... what you are viewing is exactly what will appear in the final photograph. This enables you to determine the exact composition of your subjects before pressing shutter release button. Even when you shoot close-ups, there is no danger of accidentally cutting off a portion of your picture. To assure the sharpest possible pictures, your KSX has a three way focusing screen with diagonal split-image spot, micro-prism-image band and fresnel field... select according to your subject.

Look into viewfinder eyepiece to compose your picture.

**Split-image focusing** is helpful for the subject with either vertical or horizontal lines. Rotate focusing ring until the split image in split-image spot forms a single image. When it is out of focus, your subject is split in two parts.

**Microprism focusing** is good for the subject which lacks clear vertical or horizontal lines. Rotate focusing ring until the image in microprism-image band appears sharp.

You can also focus with any part of the area surrounding microprism-image band. This is most useful when taking pictures with ultra telephoto lenses or in close-up photography with bellows unit, macro lenses or extension rings because the other focusing aids may darken appreciably.

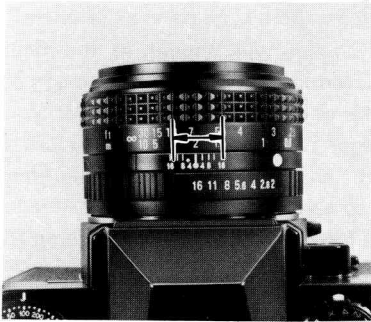

## 9. DEPTH OF FIELD

When you focus on a specific subject, an area in front of and behind the subject will appear acceptably sharp in your picture. This area of acceptable sharpness is called "Depth of Field". The depth of field is determined by the f-stop you select and the distance from the infocus subject to the film plane. As you get closer to your subject, or as you open your lens (for example, from f/16 to f/2.8), the depth of field becomes shallower. By stopping the lens down (for example, from f/2.8 to f/16), the depth of field becomes deeper. Knowing how to use depth of field allows the photographer to use the principles of "selective focus" to eliminate unwanted foreground and background objects from his photographs, and could mean the difference between a snapshot and a successful photograph.

### Depth of Field Scale:

After you have set the lens opening and have focused the camera, the area of acceptable sharpness in front of and behind your subject can also be determined on depth of field scale. Locate on depth of field scale the two numbers corresponding to the f-stop you have set on f-stop ring. The distance between these two f-stops on distance scale will be an area of acceptable sharpness in your picture. For example, if your lens is focused at 6.7 feet (2 meters) and you shoot at 16 (f/16), the area of acceptable sharpness will be from 5 ft. (1.5 m) to 10.7 ft. (3.2 m), by reading distance scale opposite both sides of the number "16" on the depth of field scale.



### Tips for Better Results:

- ★ Do not depress the shutter release button when depressing depth of field preview button.

## 10. INFRARED PHOTOGRAPHY

For infrared photography using infrared films, a correction of distance scale is necessary because infrared light waves focus on a plane slightly behind that of visible light. When using infrared film you can compensate for this difference by focusing slightly behind your subject.

First focus normally on your subject and note the camera-to-subject distance opposite the distance index line on distance scale. Turn focusing ring until this camera-to-subject distance setting is opposite the infrared index line. For example, if distance scale reads 16.5 ft. (5 m) after focusing, merely shift the "16" (5) scale to the "●" (red) position.

### Tips for Better Results:

- ★ Infrared radiation varies with the degree of infrared light rays in the atmosphere.
- ★ For exposure, follow the instruction sheets which are packed with the film and expose manually because metering with the built-in exposure meter is not possible.

## 11. HOLDING THE CAMERA

Support the camera in the palm of the left hand, with the thumb and forefinger gripping the focusing ring.

The palm of the right hand should fit against the right side of the camera body with the forefinger resting near the shutter release button and the thumb on the camera back.

Look through the viewfinder with the camera resting against the forehead to help steady it, and the left elbow held in against the body.

As a general rule, the camera should be hand held at shutter speeds slower than 1/60 second. This becomes particularly important when using lenses of longer than normal focal length, where it may be necessary to use even faster speeds to eliminate camera movement. At speeds slower than 1/60, a tripod is a must for the sharpest photographs.

**IMPORTANT:** When attaching the camera to a tripod that has a long attachment screw, adjust the screw to less than 1/4 inch to prevent damage to the interior of the camera body.

## 12. CHANGING LENSES

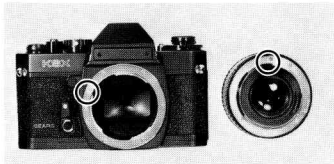

### To mount the lens on the camera:

Mount the lens by lining up the red dot on the lens mount with the matching dot on the camera mount. Grasp the lens firmly around the lens barrel and turn it clockwise until it clicks into place.

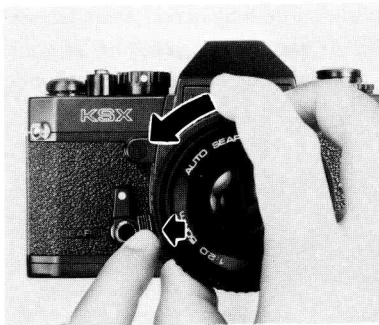

### To remove the lens from the camera:

Grasp the lens firmly around the lens barrel in one hand. With the other hand, hold the camera body and press lens release lever and turn the lens counterclockwise until it stops. The lens now can be removed.

You can also change lenses easily without looking, even in the dark, by means of lens locator node. Line up lens locator node with lens release lever and turn the lens clockwise for mounting the lens. For removing the lens, press lens release lever and turn the lens counterclockwise until lens locator node and lens release lever line up.

### **Tips for Better Results:**

- ★ Whenever a lens is mounted on the camera, make sure that the lens is perfectly mounted.
- ★ Do not touch any of the internal parts or permit dust or dirt to enter the camera body when removing or attaching lenses.
- ★ Protect the inside of the camera by putting on the body cap whenever the camera is carried or kept with the lens removed.

**NOTE:** A wide range of Sears interchangeable lenses including extremely wide angle lenses, telephoto lenses and zoom lenses are available to enable you to expand the pleasure of your picture-taking. Since the camera is designed to accept any lens with the "K" type bayonet mount, your K SX affords you the opportunity to select any interchangeable lens or accessory of the "K" type bayonet mount available on the market.



### 13. USING SELF-TIMER

Your K SX has a built-in self-timer which delays the shutter release a maximum of 10 seconds. This enables you to include yourself in your own pictures and is also of benefit in taking close-ups or photomicrographs where camera movement must be avoided.

First, advance film advance lever. Then move self-timer lever counterclockwise. According to the degree you have moved it, you can adjust the operating time. For the maximum delay, move it until it stops. Press shutter release button to start the self-timer moving.

#### Tips for Better Results:

- ★ Shield the viewfinder eyepiece by viewfinder eyepiece blind when using self-timer on automatic exposure.
- ★ You can set self-timer lever first, if you wish, and then advance film advance lever.
- ★ The camera should be placed on a tripod or other sturdy support when using self-timer.
- ★ When using a tripod with a long thread length, be careful not to forcibly screw in the thread further than the depth of socket.
- ★ Turn the self-timer lever to the original position with your finger to disengage the self-timer setting.
- ★ Please do not try to turn a shutter speed dial while a self-timer is working.

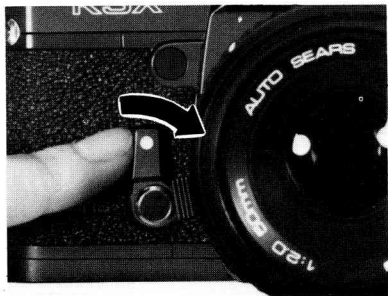

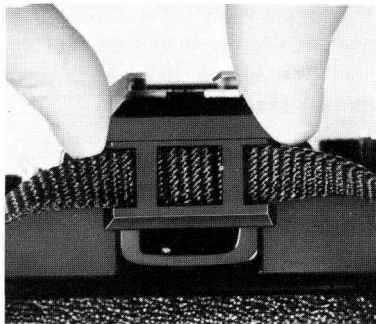

## **14. VIEWFINDER EYEPIECE CAP**

When shooting with the self-timer or cable release where you will not be viewing through viewfinder eyepiece at the time the exposure is made, viewfinder eyepiece cap should be used to prevent stray light from entering through the eyepiece and affecting the automatic exposure system.

## **15. USING AUTO WINDER**

The Sears KS Autowinder can be used with the KS1000, KS Auto and KSX cameras. By operating the shutter release button on the winder, it can be used for rapid sequence photography at approximate 2 frames per second (at shutter speed 1/125 sec.). By just setting the selection switch you may choose frame-by-frame shots or rapid sequence shots according to your needs. You can for instance capture the rapid movement in sports, or the fleeting facial expressions that make your picture-taking a more enjoyable experience.

## 16. UNLOADING FILM

After the last picture on the roll of film has been taken, rewind the film and unload your camera as follows:

Press the film rewind release button.

Lift up film rewind crank and turn it clockwise until film rewind release button stops revolving and you feel the film tension released. This indicates that the film has been completely rewound into the cartridge.

Open back cover by pulling film rewind knob.

Remove the film cartridge and have the film processed as soon as possible.

### Tips for Better Results:

- ★ Always unload your camera in the shade or in a poorly-lit place, never in direct sunlight or other bright light.
- ★ When you reach the end of the roll of film, film advance lever will tighten and refuse to advance. If this happens, do not advance film advance lever by force for "just one more shot", otherwise the film will be torn out of the cartridge.
- ★ Film rewind release button will remain in place once it is pressed, and return automatically to its original position when film advance lever is advanced.

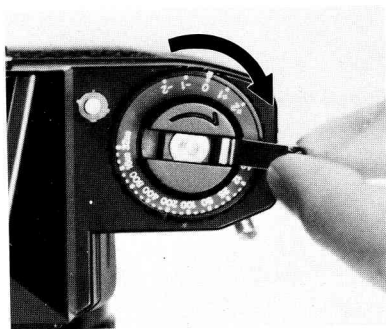
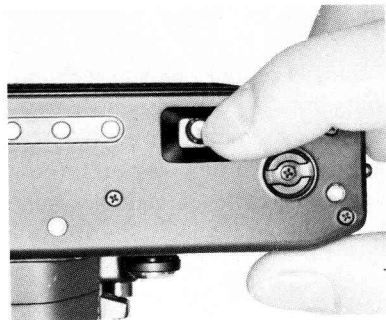

## 17. FLASH PHOTOGRAPHY

You can use a flash at night or in a dimly lit room as well as for supplementary lighting in outdoor photography. The camera and electronic flash will be fully synchronized with the shutter speed at "B", "X" and 4 sec. to 1/125 sec. Since proper flash exposure may not be obtained by automatic exposure setting, always change shutter speed dial from "AUTO" setting to a selected speed setting.

### **Cordless electronic flash unit:**

If you are using an electronic flash unit with a built-in hot shoe contact, it can be attached directly to hot shoe on top of the camera pentaprism.

### **Tips for Better Results:**

- ★ "125" (1/125 sec.) on shutter speed dial and "X" on hot shoe are marked in red as a reminder for electronic flash synchronization.

### **Exposure for flash photography:**

The exposure is determined by the guide number of the electronic flash unit. The guide number represents a relationship between the light output of the flash and the speed of the film. Guide numbers for flash can be found on the package and guide numbers for electronic flash units are found in the technical specifications. Using the guide number, you can determine the correct f-stop for a given flash situation using the following formula:

$$\text{F-stop} = \text{Guide number} \div \text{Flash-to-subject distance}$$

For example, if your flash unit has a guide number of 52.8 (ft.) or 16 (m) for the type of film you are using, and your subject is 2 meters (6.6 ft.) from the flash unit as indicated on distance scale after focusing, divide 16 (52.8) by 2 (6.6). The answer is 8; therefore, set f-stop ring at 8 (f/8).

### Tips for Better Results:

- ★ If you are using an auto electronic flash unit with power ratio control, follow the instruction sheets packed with flash unit.
- ★ Most electronic flash units have a built-in dial or exposure table which enables you to quickly compute f-stops based on flash-to-subject distances.
- ★ The Sears 8025 Auto Flash is available exclusively for use with the Sears KSX camera for automatic flash photography. Upon charging with the flash unit, the Flash LED on the frame of the view finder eye-piece will turn red indicating it is ready for use.

## 18. TROUBLE SHOOTING YOUR CAMERA

The proper operation of a precision instrument like the Sears KSX camera requires strict attention to the correct manipulation of controls. In many cases, the camera may appear to malfunction simply because some small detail was overlooked, or the operations were not in the proper sequence. Before you decide the camera is broken, there are some things you can look for.

**Problem:** EXPOSURE METER NEEDLE WILL NOT MOVE TO TAKE READING

**Possible cause:** Improper shutter speed/aperture combination for film and light conditions. Try changing the shutter speed/aperture combination until needle reacts. Or check to see that the correct type of battery is being used and has been inserted correctly.

**Problem:** FILM COMPLETELY BLANK WHEN PROCESSED, INDICATED NO EXPOSURE HAS BEEN MADE.

**Possible cause:** Improper loading. Review the section on film loading and be sure you are loading the camera correctly with the film being securely attached to the take-up spool and winding in the CORRECT DIRECTION, that is, UNDER the take-up spool. Film may not have gone through camera at all.

**Problem:** SELF TIMER DOES NOT OPERATE SHUTTER.

**Possible cause:** Timer not rotated at least 90 degrees.

**Problem:** LENS VERY HARD TO REMOVE FROM CAMERA. STOP IMMEDIATELY!

**Possible cause:** Pressure on film advance lever causing automatic diaphragm actuating plate to press against pin on back of lens. THIS CAN CAUSE SERIOUS DAMAGE TO YOUR LENS. DO NOT FORCE THE LENS! Check to be sure the film advance lever is retracted.

**Problem:** FLASH PICTURES BLANK OR PARTIALLY EXPOSED.

**Possible cause:** Improper shutter speed for the type of flash used, or improper cord receptable

used for the type of bulb or shutter speed. Check Flash Synchronization Table carefully.

**Problem:** SHUTTER WILL NOT RELEASE.

**Possible cause:** Film advance lever not advanced far enough. A full stroke is necessary to cock the shutter.

**Problem:** MIRROR HANGS UP AND SHUTTER JAMS.

**Possible cause:** Improper loading of batteries.

Turn the shutter speed dial to "X" or "B" to put the mirror back to its proper position.

Be sure two batteries are fresh and loaded properly (See page 7) and that the battery holder and the battery contact are clean.

If the problems above cannot be solved in the manners suggested, do not attempt to repair the camera yourself. Take it to the nearest service center. A minor problem could be aggravated by tampering.

## 19. PROPER CARE OF YOUR CAMERA

- ★ Always carry your camera with its carrying case and neck strap.
- ★ Use the lens cap to protect the lens when not taking pictures.
- ★ Protect your camera from dust, dirt, water, rain, dampness, salt air and rough handling.
- ★ Never expose your camera to excessively high or low temperatures for an extended period of time. In extremely hot climates, do not leave your camera inside closed automobiles during the daytime or in direct sunlight. In extremely cold climates, expose your camera to the outer air only when in use... when using, expose your camera gradually to the outer air to prevent the lens from clouding. If exposed to an extremely cold climate, the exposure meter batteries may fail to operate properly. Keep your camera inside your clothing until taking a picture.
- ★ Never touch the surfaces of the lens, metal focal plane shutter curtain, reflex mirror, etc. with your fingers.
- ★ To clean the lens, gently wipe it in a circular motion with a lens cleaning paper or a soft, clean and lintless cloth.
- ★ Do not wipe the camera body with chemicals such as benzine, thinner, etc. Use only soft cloth or cotton swab sprinkled LIGHTLY with alcohol on the camera body. Do not use them on the lens because it can affect coating.
- ★ When your camera is not in use for an extended period of time, put the lens cap on, remove the batteries, place your camera in its carrying case together with silica gel or other desiccant and store it in a dry and cool place. Never store your camera in places where the temperatures are excessively high or low.
- ★ Do not attempt to disassemble or repair your camera yourself. If service is necessary, take the camera to the nearest Sears store.