

**This camera manual library is for reference and historical purposes, all rights reserved.**

**This page is copyright by mike@butkus.org M. Butkus, N.J.**

**This page may not be sold or distributed without the expressed  
permission of the producer**

**I have no connection with any camera company**

**If you find this manual useful, how about a donation of \$3 to: M. Butkus, 29 Lake Ave., High Bridge, NJ 08829-1701 and send your E-mail address too so I can thank you. Most other places would charge you \$7.50 for a electronic copy or \$18.00 for a hard to read Xerox copy. These donations allow me to continue to buy new manuals and maintain these pages. It'll make you feel better, won't it?**

**If you use Pay Pal, use the link below. Use the above address for a check, M.O. or cash. Use the E-mail of butkusmi@ptd.net for PayPal.**



**[back to my "Orphancameras" manuals /flash and light meter site](#)**

**Only one "donation" needed per manual, not per multiple section of a manual !**

**The large manuals are split only for easy download size.**



MINOLTA

---

# MAXXUM FLASH      3500xi

# PROGRAM FLASH

---

**Minolta Camera Co., Ltd.**

**Minolta GmbH**

**Minolta France S.A.**

**Minolta (UK) Limited**

**Minolta Austria Gesellschaft m.b.H.**

**Minolta Camera Benelux B.V.**

**Belgium Branch**

**Minolta (Schweiz) AG**

**Minolta Svenska AB**

**Finland Branch**

**Minolta Portugal Limitada**

**Minolta Corporation**

**Head Office**

**Los Angeles Branch**

**Minolta Canada Inc.**

**Head Office**

**Vancouver Branch**

**Minolta Hong Kong Limited**

**Minolta Singapore (Pte) Ltd.**

**3-13, 2-Chome, Azuchi-Machi, Chuo-Ku, Osaka 541, Japan**

Kurt-Fischer-Strasse 50, D-22923 Ahrensburg, Germany

365-367 Route de Saint-Germain, 78420 Carrières-Sur-Seine, France

1-3 Tanners Drive, Blakelands North, Milton Keynes, MK14 5BU, England

Amalienstrasse 59-61, 1131 Wien, Austria

Zonnebaan 39, 3606 CH Maarssenbroek, P.B. 264, 3600 AG Maarssen, The Netherlands

Kontichsesteenweg 38, B-2630 Aartselaar, Belgium

Riedhof V, Riedstrasse 6 8953 Dietikon-Zürich, Switzerland

Brännkyrkagatan 64, Box 17074, S-10462 Stockholm 17, Sweden

Niitykatu 6 PL 37 SF-02201 ESPOO, Finland

Av. do Brasil 33 a, 1700 Lisbon, Portugal

101 Williams Drive, Ramsey, New Jersey 07446, U.S.A.

11150 Hope Street Cypress, CA 90630, U.S.A.

369 Britannia Road East, Mississauga, Ontario L4Z 2H5, Canada

106-3850 Jacombs Road, Richmond, B.C. V6V 1Y6, Canada

Room 208, 2/F, Eastern Center, 1065 King's Road, Quarry Bay, Hong Kong

10, Teban Gardens Crescent, Singapore 2260



MINOLTA

## 1. POWER

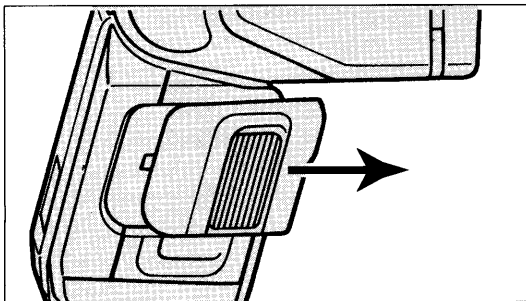

This flash is powered by four AA-size batteries. Either alkaline-manganese or rechargeable nickel-cadmium (Nicad) batteries can be used.

### To install the batteries:

1. Slide the battery cover out, as shown.

- The terminals of the batteries being installed should be kept clean. If necessary, wipe the terminals with a clean, dry cloth.

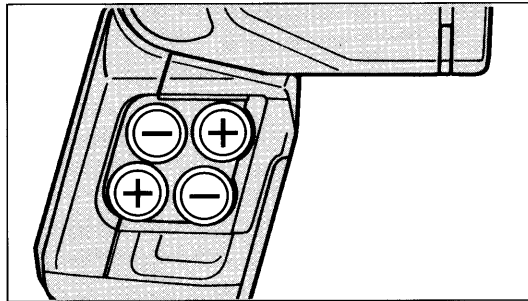

2. Insert the batteries, making sure their terminals are oriented as indicated inside the chamber.

3. Replace the battery cover by aligning it with the chamber grooves, then sliding it fully in so that it locks.

## 2. LENS

This flash provides coverage for lens focal-length settings down to 28 mm; if you use a wider focal-length setting, vignetting may occur.

## 3. FILM

For flash pictures taken with 3500xi, films within the ISO 25 to 1000 range should be used; if you use film outside this range, correct exposure may not be obtained.

Thank you for purchasing this product. Maxxum/Program Flash 3500xi is designed specifically for use with xi camera bodies; although its full potential will be realized only when used in combination with an xi camera body, it can also be used with i-series camera to the extent that these bodies permit.

Please read these instructions carefully before using the flash, and then keep them handy for future reference.

- Pre-flash, which is available with the xi camera's built-in flash, cannot be selected with this flash.

## NAMES OF PARTS

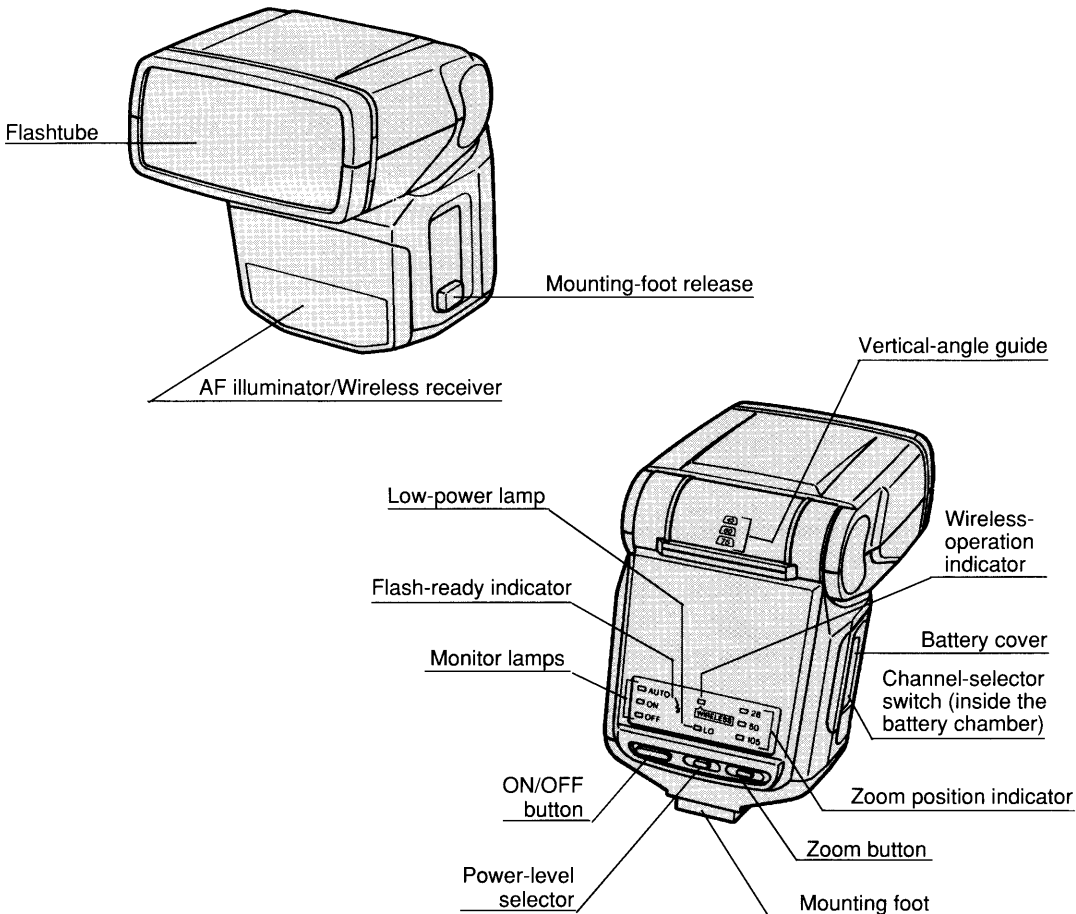

**To check the batteries:**

If the charging time is longer than the value listed below, the batteries should be changed or recharged (Nicad).

Type	Time
Alkaline-manganese	30 sec.
Nickel-cadmium	10 sec.

**Cold-weather Operation**

In cold weather, always use fresh batteries and keep a spare set warm in an inside pocket. For prolonged use near or below 0°C (32° F), Nicad batteries are recommended. Do not discard cold batteries. Their capacity will be restored when they are returned to room temperature.

**Battery Cautions**

- Read and follow all warnings and instructions supplied by the battery manufacturer.
- When inserting batteries, make sure that the ⊕ and ⊖ terminals face in the correct directions.
- Never use batteries that show signs of leaking or cracking.
- To prevent battery leakage or bursting, never mix batteries of different types, brands, or ages.
- Used batteries should not be discarded in fire.
- Keep batteries away from children.
- If batteries are not inserted correctly, flash will not charge and leaking or bursting may result.
- If the flash will not be used for more than two weeks, batteries should be removed.

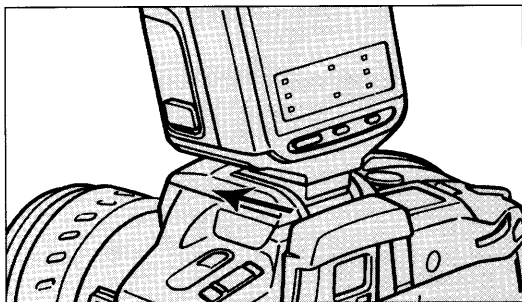
**4. ATTACHING AND REMOVING THE FLASH**

**To attach:** Slide the flash's mounting foot into the camera's accessory shoe until it locks.

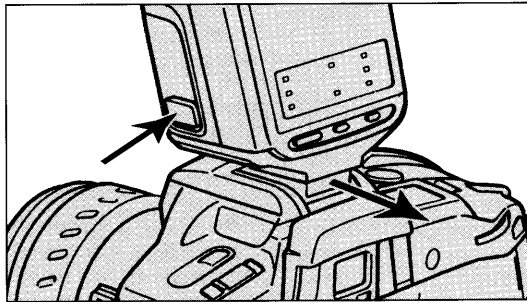

**To remove:** While pressing in on the flash's mounting-foot release, slide the flash straight out of the accessory shoe, as shown.

## 5. TURNING THE FLASH ON AND OFF

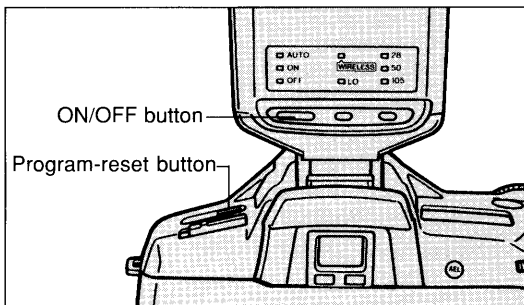

Once attached to the camera body, the flash can be switched on either by pressing its ON/OFF button, or by pressing the camera's program-reset button. In the latter case program exposure mode will be set, and monitor lamps besides the words AUTO and ON on the flash's back panel will glow; when the flash is used in any other exposure mode (A, S, or M) only the monitor lamp adjacent to the word ON glow.

The difference between AUTO ON and ON relates to the way in which the camera controls the flash: in AUTO ON mode, the flash may or may not fire when the shutter is released, based on the metering system's evaluation of the ambient lighting; at ON, the flash fires each time the shutter is released, regardless of the existing light level. In either case, flash output is automatically controlled by TTL off-the-film-plane metering for correct exposure.

Once the flash is switched on, if more than about eight seconds elapses without further operation, the monitor lamps are automatically extinguished; the flash remains in a standby state in this case, however, and the monitor lamps will be restored when you resume operation. Similarly, about eight seconds after the flash is switched off, the monitor lamp adjacent to OFF will disappear.

## 7. P-MODE AUTOFLASH

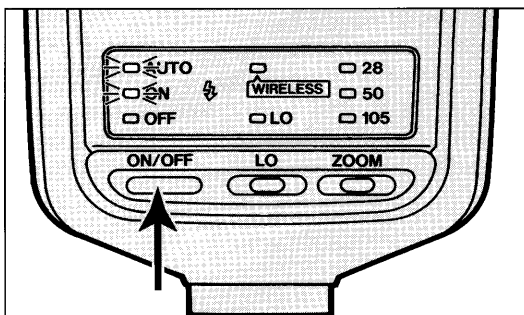

To use P-mode autoflash, which is the easiest way to take flash pictures, proceed as follows.

1. Set the camera to P mode and switch the flash on.

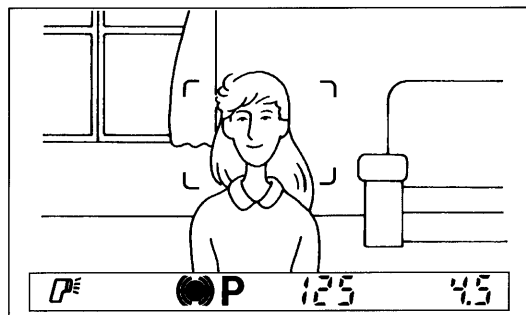

2. Focus on your main subject.

● If the camera's metering system determines that your subject requires flash for correct exposure, the viewfinder data panel's flash-on indicator  $P^{\#}$  glows to indicate that the flash will fire when you release the shutter.

## 8. A-MODE AUTOFLASH

When the flash is used with your camera set to A mode, it will fire each time a picture is taken. Using A-mode autoflash you can directly set the aperture and thereby control depth of field; in addition, for subjects at relatively short distances, setting a large aperture tends to reduce the flash recycling time.

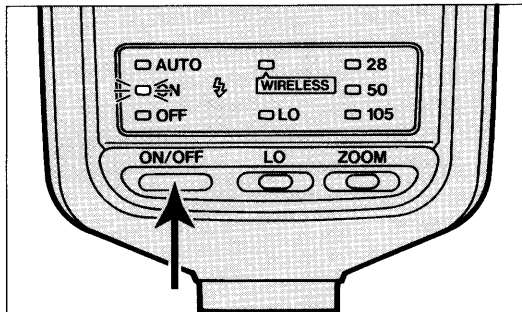

### To Use A-Mode Autoflash:

Making sure the flash is switched on (ON lamp glows in the flash's back panel), operate the camera in A mode the same way as you would without flash setting the aperture to produce the desired effect. When the flash-ready indicator ⚡ appears, press the shutter-release button down to take the picture.

## 11. FLASH CONTROL

	Flash setting	Flash burst	Aperture set	Shutter speed
<b>P mode</b>	AUTO ON	Fires when needed	Automatic	Automatic (Slower than)
	OFF	Doesn't fire		Automatic
<b>A mode</b>	ON	Always fires	Manual	Automatic to
	OFF	Doesn't fire		Automatic
<b>S mode</b>	ON	Always fires	Automatic	Automatic (s)
	OFF	Doesn't fire		Manual
<b>M mode</b>	ON	Always fires	Manual	Manual (from X-synco)
	OFF	Doesn't fire		Manual

## 6. AF ILLUMINATOR

In low-light, low-contrast situations, the flash's AF illuminator will be activated when the shutter-release button is pressed lightly. The focus-assist illumination that it projects onto the subject enables the camera's AF system to continue functioning in situations where operation would otherwise be impossible. The illuminator's range is 0.5 - 9 meters (1.6 - 30ft.), based on Minolta's standard test method using a 50 mm lens.

- When the flash is attached directly to the camera and AF illumination is required, either the flash's or the camera's AF illuminator operates, depending on the ambient light level: above a certain level the camera's AF illuminator operates, and below that level the flash's does.
- In off-camera flash operation only the camera's AF illuminator operates.
- If the subject's reflectivity is too low, autofocus may not operate.
- The AF illuminator may not operate with long focal length lenses.

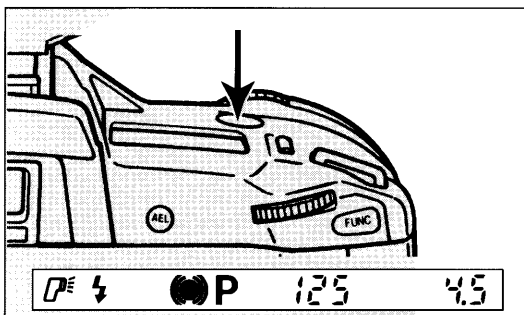

3. When the flash is charged, press the shutter-release button down to take the picture.

- The flash-ready indicators ⚡ in the camera's viewfinder and on the flash's back panel glow when the flash has charged.

- Following the exposure, the viewfinder's flash-ready indicator blinks if sufficient exposure was received at the film plane.
- You can force to fire the 3500xi in program mode by keeping the camera's flash pop-up button pressed in while releasing the shutter.

## 9. S-MODE AUTOFLASH

When the flash is used in S mode, both shutter speed and aperture settings will be made automatically by the camera.

## 10. M-MODE AUTOFLASH

As in A mode autoflash operation, the 3500xi fires each time the shutter is released. Operate the camera as you would in M mode without flash, except that you should be sure to set the shutter speed slower than the camera's top X-sync speed.

After checking that your subject is within the flash range and that the flash has charged, press the shutter-release button down to take the picture.

When you use the 3500xi with the 9xi, setting the shutter speed in A mode and S mode is different than described in this manual. Refer to the 9xi's manual for details.

Shutter speed set	AE lock button
(X-sync speed)	Slow-shutter sync
	AE lock
(X-sync speed (slower speed is available with AE lock button))	Fill flash Slow-shutter sync
	AE lock
(slower than X-sync speed, same control as in P mode)	Slow-shutter sync
	AE lock
(shutter speed to 30 sec.)	—
	AE lock

## 12. FILL FLASH

Getting good pictures of backlit scenes has until recently been among the most challenging situations a photographer could face, even those with many years of experience. The problem is caused by the extreme difference in lighting levels of the main subject and background. While aperture and shutter speed could be controlled for correct exposure of the main subject, this would often leave a washed out background showing little detail.



With fill flash

Fill flash provides a solution to this problem: by using a flash burst when the picture is taken, the difference in lighting levels of main subject and background can be reduced to obtain correct exposure in both parts of the scene.

In P mode, fill flash is automatic when the camera's metering system detects sufficiently strong backlight. In A and M modes, the flash fires each time a picture is taken, regardless of the lighting level.



Without fill flash

## 13. SLOW-SHUTTER SYNC

Slow-shutter sync is useful for increasing ambient exposure of background picture areas, and can be selected in P and A auto-flash modes. When selected, the camera reduces the shutter speed while controlling flash output for correct exposure of the main subject.

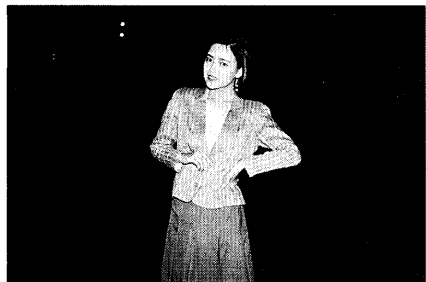
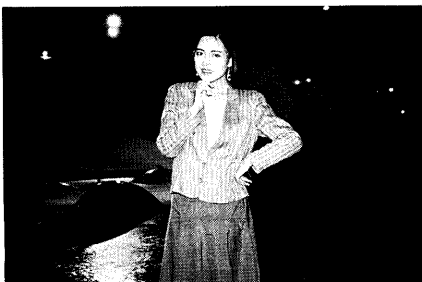

## 14. FLASH RANGE

Flash range will vary with the film speed, aperture, and lens focal length. The table below shows the flash range when used with 28-105 mm F3.5-4.5 lens.

	ISO 100	ISO 400
28 mm	2.3-21 ft (0.7-6.3 m)	2.3-41 ft (0.7-12.6 m)
105 mm	3.3-26 ft (1.0-7.8 m)	3.3-51 ft (1.0-15.6 m)

Diagram at right shows how the flash range with other lenses changes according to lens focal length, etc. For correct flash exposure, make sure that your subject falls within the appropriate range.

To determine the flash range for the film and aperture being used, refer to the graph

shown. Find the selected lens aperture on the vertical line for the appropriate film speed (ISO). Imagine a horizontal line drawn across the graph from this point. The minimum and maximum subject distances are indicated by the points where this line intersects the lower and upper set of diagonal lines, respectively.

For example, the bold line drawn on the graph shows how to determine the flash range using ISO 100 film, a 50 mm focal length setting at f/2; in this case the flash range would be 0.5-14 m (1.6 - 46ft).

When the 3500xi is attached directly to the camera, the minimum camera-subject distance is 0.7 m (2.3 ft), regardless of the film speed. If the subject is closer than 0.7 m, use an off-camera flash.

## 15. POWER-LEVEL SELECTION

When the camera is set to A, S, or M mode, you have the option of selecting low power; while maximum flash range will be reduced at this setting, it gives you the advantage of a quicker recycling time.

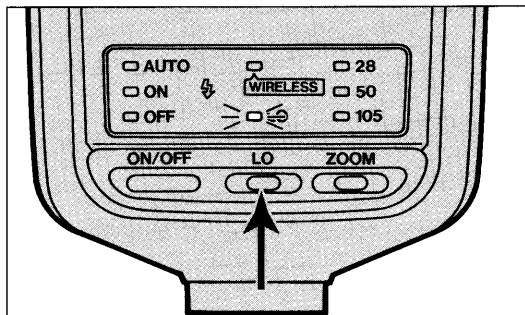

### To set Low Power:

With the flash switched on, press the power-level selector so that the low-power lamp glows; pressing the selector again, so that the lamp is extinguished, returns the camera to full-power operation.

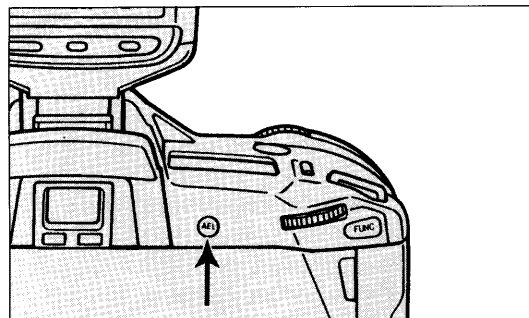

● In flash pictures made at dawn or dusk, or into other situations characterized by low ambient lighting, improved background rendition may be obtained by keeping the camera's AE Lock button pressed in while releasing the shutter. Refer to the following section for details.

● If you use fill flash in A mode with a large aperture set, the shutter speed may not be reduced and your subject may be overexposed.

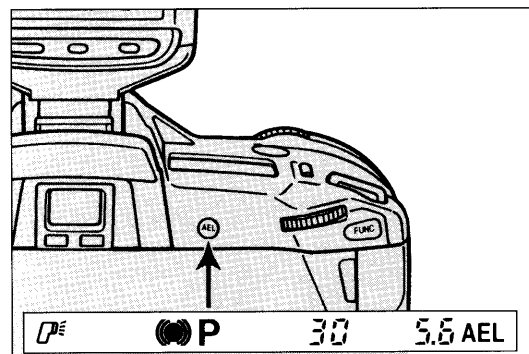

**To operate slow-shutter sync:**

1. Focus on your main subject.
2. While pressing in the AE Lock button, press the shutter-release button all-the-way down to release the shutter.

- If the background is bright or a large aperture is set, the shutter speed may not be reduced.
- When you use slow-shutter sync, attaching the camera to a tripod is recommended.

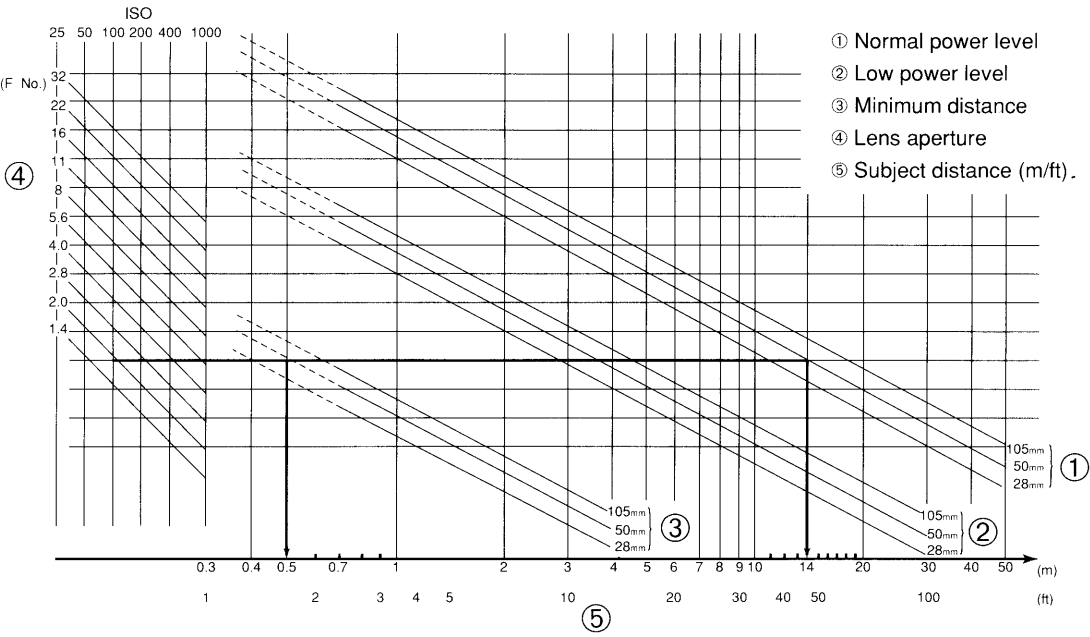

## 16. ZOOM CONTROL

When the flash is set for standard operation, its flash head zooms automatically to provide coverage suitable for the current lens-focal-length setting. Alternatively, you can manually set the flash head to one of three zoom positions by pressing the flash's zoom button.

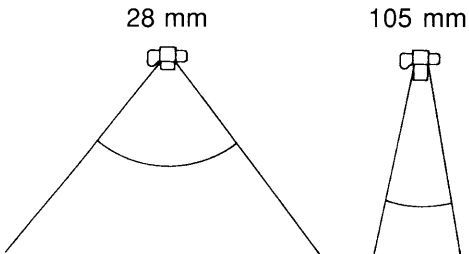
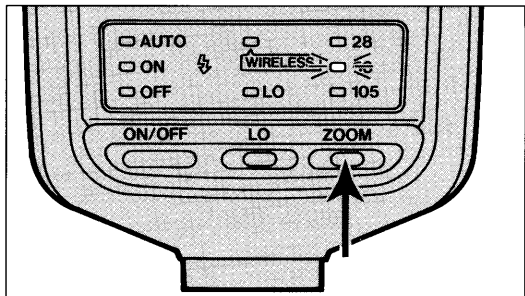

When you press the zoom button in succession, the zoom position changes as shown below.

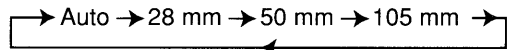

Note: When automatic setting of zoom head is in use, there is no light indication.

● If the zoom position that you set is higher than the actual focal-length, vignetting may occur.

# 17. BOUNCE FLASH

Reflecting the flash's light off a nearby surface provides softer lighting effect than direct flash, and with certain types of subjects may give more pleasing results. To create bounce-flash photographs, the flash head can be rotated up to 90° from its direct position (A).

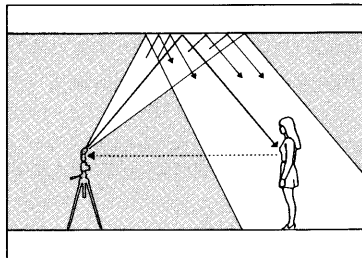

(A)



Bounce flash



Direct flash

# 18. WIRELESS/REMOTE OFF-CAMERA FLASH CONTROL

When used with xi camera, this flash can be set for wireless/remote, off-camera operation; the stand supplied (Mini Stand MS-2) is provided for this purpose. Refer to the camera's instruction manual for more information.

To select wireless/remote mode without attaching the flash to the camera, press and hold the ON/OFF button until the wireless/remote-operation indicator lights (This procedure cannot be used with the 5xi or 3xi cameras).

Mini Stand

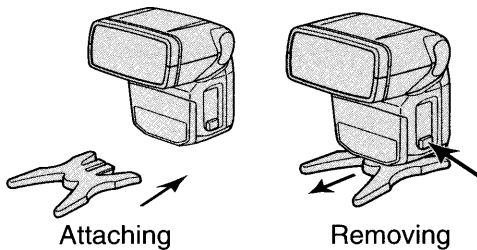

## 20. NOTES ON TAKING FLASH PICTURES

- Never fire the flash at close range into the eyes of peoples or animals.
- If the subject is at the near end of the flash range when the flash is attached to the camera, exposure will not be correct because of the difference in alignment of the flash and lens axis.
- Exposure may not be adequate if the shutter is released before the flash is charged.
- When using the self-timer, make sure that the flash is fully charged before releasing the shutter.
- When using reversal film, if the shutter is released just after the flash is charged, or if it takes more than 30 sec. to reach full charge, exposure may not be sufficient at the far end of the flash range.
- In pictures of people taken with flash your subject's eyes may appear red. "Red-eye," as the effect is called, is caused by light from the flash reflected back into the lens from the subject's retinas, and will be more noticeable in some subjects than in others. To minimize red eye, we recommend increasing the overall light level as much as possible, and getting as close as possible to the near end of the flash range without the flash discharge becoming a disturbance.
- The flashtube may become hot when the flash is discharged. Be sure to leave sufficient space around the flashtube during operation.

## 22. TECHNICAL DETAILS

**Type:** Fully dedicated autoflash for Minolta xi-series cameras with power zoom head and AF illuminator

**Exposure control:** Direct autoflash (TTL off-the-film) metering in all flash exposure modes based on camera's film speed setting

**AF illuminator:** Focus assist LED's automatically activated in low light, low contrast situations; range (based on Minolta's standard test method using a 50 mm lens): 1.6 - 30ft (0.5-9m)

**Controls:** ON/OFF button, power-level selector, zoom button

**Coverage:** Power-zoom head automatically adjusted for correct flash coverage for focal lengths between 28 mm and 105 mm; manual adjustment of zoom position also selectable

**Flash Duration:** Approximately 1/50,000 to 1/800 sec.

**Bounce Capability:** Flash head can be rotated up to 90° vertically from normal position with click stops at 45°, 60°, 75°, and 90°

**Guide Number (GN):** At ISO 100, in feet:

	Lens focal length				
	28	35	50	80	105
Normal	72	85	95	108	115
Low	18	21	24	27	29

**Indicators:** Monitor lamps, flash-ready, wireless operation, low-power, zoom position

**Power sources:** Uses four AA-size batteries, either 1.5V alkaline-manganese or 1.2V rechargeable nickel-cadmium types

For optimum light diffusion, the bounce surface should be light in tone and should disperse light broadly; a shiny surface is not desirable. In addition, for color photography the surface should be neutral in tone in order to achieve a natural color rendition.

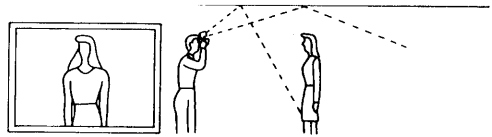

To use bounce flash, the flash head should be aimed so that the subject does not receive direct flash illumination (B). According to the lens focal-length setting, the following bounce angles are recommended (the direct position is taken to be 0°):

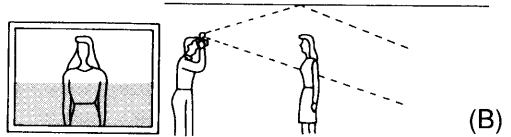

Focal length of the lens	Angle
More than 70 mm	45°
More than 28 mm	60°, 75°, 90°

- When you use bounce flash, flash range will be shorter than otherwise. You can confirm whether or not exposure was sufficient by checking for the blinking flash-ready indicator  in the viewfinder following exposure.

## 19. USE WITH i-SERIES CAMERA BODIES (8000i/7000i/5000i/3000i)

When the flash is used in combination with an i-series body, note the followings;

- When flash is charged, viewfinder's flash-ready indicator blinks.
- Wireless off-camera operation is not possible.
- If used in combination with an 8000i or 7000i body with focal length settings longer than 75 mm, only the center focus area will be available for autofocusing.
- With 7000i, 5000i, or 3000i, you cannot force to fire the flash in P mode.
- With 8000i or 7000i, AE lock button is replaced by SPOT button.

## 21. CARE AND STORAGE

- This flash is not waterproof. If it comes in contact with water wipe it dry with a clean cloth and bring it to an authorized Minolta service facility.
- If the flash is subjected to a sudden change in temperature, as when transferring it from a cold environment into a heated building, condensation may form inside. To prevent condensation, place the unit in a sealed plastic bag before transferring it from a cold to a warm environment, and wait for it to come to room temperature before taking it out of the bag.
- The flash may not operate satisfactorily at temperatures above 122°F (50°C) or below 14°F (-10°C).
- When dirty, the flash unit may be cleaned with a clean, dry cloth. Do not allow alcohol or other chemicals to come in contact with the flash.

- Never subject the flash to shock, high heat, or high humidity. Be particularly careful not to leave it in the glove compartment or other places in motor vehicles where it may be subjected to high temperatures.
- When storing the flash for more than two weeks, remove the batteries and store the flash in a cool, dry place away from dust or chemicals.
- The flash contains high-voltage circuit's. Never attempt to disassemble the flash. Any repairs should be done by an authorized Minolta service facility.
- Fire the flash at least several times a month to keep it in good operating condition.

To assure prompt service, contact your nearest authorized Minolta service facility before shipping your flash unit for repair.

**Battery performance:** With alkaline-manganese batteries;  
Flash per set: 220-3500  
Recycling time: 0.2-5 sec.  
Charging times may be exceeded with newly purchased batteries if they have been in prolonged storage.

**Flash-camera contacts:** Contacts on attaching foot for firing flash, automatic setting of zoom-head position, X-sync speed, activating viewfinder's flash-ready indicator, direct auto-flash metering, and triggering AF illuminator

**Standard accessory:** Mini Stand MS-2

**Other:** When flash is attached to camera and camera's Program Reset button is pressed, flash is automatically switched on and set to its standard settings: AUTO ON flash mode, auto zooming, and full power

**Dimensions:** 3 × 4-1/8 × 3-7/8 in.  
(76 × 104.5 × 99 mm)

**Weight:** 8-1/8 oz (230 g)

Specifications are based on the latest information available at the time of printing and are subject to change without notice.