

This manual is for reference and historical purposes, all rights reserved.

This page is copyright© by M. Butkus, NJ.

This page may not be sold or distributed without the expressed permission of the producer

I have no connection with any camera company

On-line camera manual library

This is the full text and images from the manual. This may take 3 full minutes for the PDF file to download.

If you find this manual useful, how about a donation of \$3 to: M. Butkus, 29 Lake Ave., High Bridge, NJ 08829-1701 and send your e-mail address so I can thank you. Most other places would charge you \$7.50 for a electronic copy or \$18.00 for a hard to read Xerox copy.

This will allow me to continue to buy new manuals and pay their shipping costs.

It'll make you feel better, won't it?

**If you use Pay Pal or wish to use your credit card,
click on the secure site on my main page.**

PayPal Name Lynn@butkus.org

E INSTRUCTION MANUAL

DYNAX™

303si

MAXXUM®

QTsi

Butkus.us

**QUICK
OPERATION**

**BASIC
OPERATION**

**SUBJECT
PROGRAM
SELECTION**

**ADDITIONAL
FEATURES**

APPENDIX



MINOLTA

Thank you for purchasing a Minolta camera. This manual has been designed to help you understand the operation of your Minolta camera more quickly. After familiarizing yourself with the camera, start with Basic Operation and learn to operate the camera in Full-Auto mode. Move on to Subject Program selection when you are comfortable with the camera and want to have more control. Here you decide the type of image you want to photograph and leave the exposure details to the camera.

The information in this manual is relevant for products introduced before June, 1999. Contact the nearest authorized Minolta Service facility to obtain compatibility information for products released after this date.



This mark certifies that this product meets the requirements of the EU (European Union) concerning interference causing equipment regulations. CE stands for Conformité Européenne (European Conformity).

This device complies with Part 15 of the FCC Rules. Operation is subject to the following two conditions: (1) This device may not cause harmful interference, and (2) this device must accept any interference received, including interference that may cause undesired operation. Changes or modifications not approved by the party responsible for compliance could void the user's authority to operate the equipment. This equipment has been tested and found to comply with the limits for a Class B digital device, pursuant to Part 15 of the FCC Rules. These limits are designed to provide reasonable protection against harmful interference in a residential installation. This equipment generates, uses and can radiate radio frequency energy and, if not installed and used in accordance with the instructions, may cause harmful interference to radio communications. However, there is no guarantee that interference will not occur in a particular installation. If this equipment does cause harmful interference to radio or television reception, which can be determined by turning the equipment off and on, the user is encouraged to try to correct the interference by one or more of the following measures:

- Reorient or relocate the receiving antenna.
- Increase the separation between the equipment and the receiver.
- Connect the equipment to an outlet on a circuit different from that to which the receiver is connected.
- Consult the dealer or an experienced radio/TV technician for help.

This Class B digital apparatus complies with Canadian ICES-003.

www.butkus.us

FOR PROPER AND SAFE USE

Read and understand all warnings and cautions before using this product.

WARNING

Batteries may become hot or explode due to improper use.

- Use only the batteries specified in this instruction manual.
- Do not install the batteries with the polarity (+/-) reversed.
- Do not subject batteries to fire or high temperatures.
- Do not attempt to recharge, short, or disassemble.
- Do not mix batteries of different types, brands, or ages.
- Tape over lithium battery contacts before disposal.
- Follow local regulations for battery disposal.

Keep batteries and other things that could be swallowed away from young children. Contact a doctor immediately if an object is swallowed.

Immediately remove the batteries and discontinue use if...

- the camera is dropped or subjected to an impact in which the interior is exposed.
- the camera emits a strange smell, heat, or smoke.

Do not disassemble. Electric shock may occur if a high voltage circuit inside the camera is touched. Take your camera to a Minolta Service Facility when repairs are required.

Do not look directly at the sun through the viewfinder.

CAUTION

Do not allow a camera lens to point directly at the sun. Fire may occur if sunlight comes to focus on a flammable surface. Replace the lens cap when the product is not being used.

TABLE OF CONTENTS

NAMES OF PARTS	4
QUICK OPERATION	8

BASIC OPERATION

Attaching the Strap.....	11
Batteries.....	12
Lens.....	14
Loading Film.....	16
Handling the Camera	18
Taking Pictures in Full-Auto.....	19
Focus	
Focus signals.....	20
Special focus situations	21
Focus hold	22
Using the Built-in Flash	
Flash signals.....	23
Flash range.....	23
Changing the flash mode.....	24
Auto flash.....	24
Auto flash with red-eye reduction	25
Fill flash.....	25
Fill flash with red-eye reduction	26
Flash cancel.....	26
Lens shadowing.....	27
Rewinding the Film	
Automatic.....	28
Manual	29

SUBJECT PROGRAM SELECTION

Portrait Mode	32
Landscape Mode	33
Close-up Mode	34
Sports Mode	35
Night Portrait Mode	36
Photographing Night Scenes	37
Self-timer	38
Continuous Advance	39
For Owners of the date model.	40
Exposing the Date/Time	41
Setting the Date/Time	42
Replacing the Battery	43

ADDITIONAL FEATURES

Manual Focus	45
AF Illuminator	46
Wireless/Remote Flash	48

APPENDIX

Accessory Information	53
Trouble Shooting	56
Care and Storage	58
Specifications	60

Beukes, US

NAMES OF PARTS

For information on specific parts, refer to the page numbers shown in parenthesis.

Body

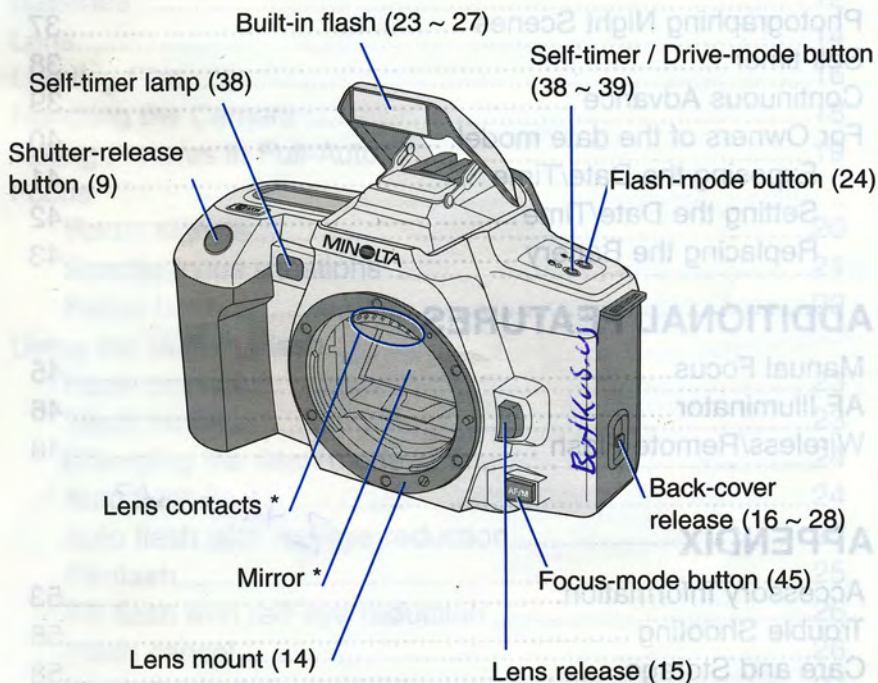



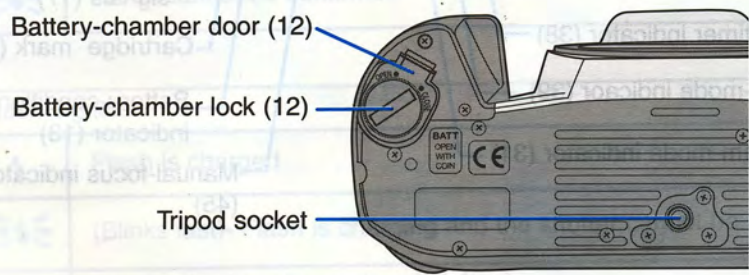
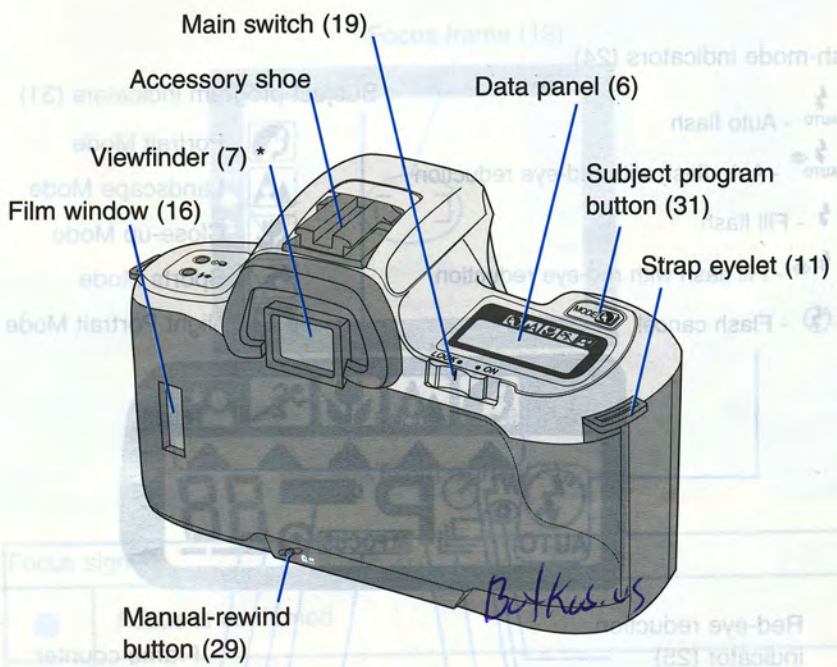

* Do not touch.







NAMES OF PARTS

Data Panel

Flash-mode indicators (24)

-  - Auto flash
-  - Auto flash with red-eye reduction
-  - Fill flash
-  - Fill flash with red-eye reduction
-  - Flash cancel

Subject-program indicators (31)

-  Portrait Mode
-  Landscape Mode
-  Close-up Mode
-  Sports Mode
-  Night Portrait Mode

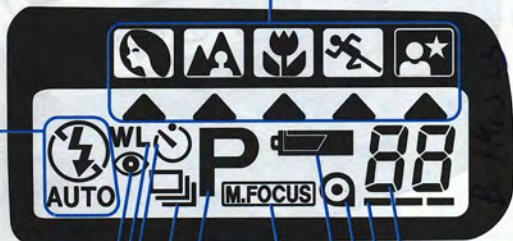



- Red-eye reduction indicator (25)
- Wireless/Remote flash indicator (48)
- Self-timer indicator (38)
- Drive-mode indicator (39)
- Program-mode indicator (31)
- Frame counter (17)
- Film-transport signals (17)
- Cartridge mark (17)
- Battery-condition indicator (13)
- Manual-focus indicator (45)

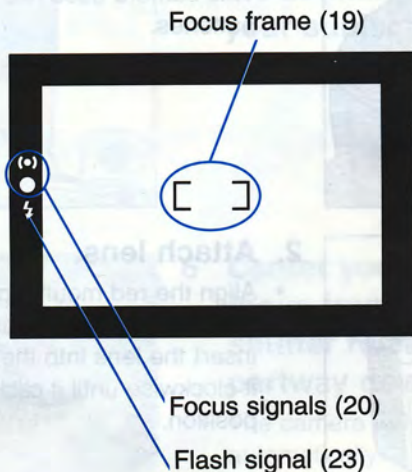

Viewfinder



Focus signals

	Focus is confirmed
	Continous focus is confirmed
	Focus cannot be confirmed

Flash signals

	Flash is charged
	(Blinks fast)- Flash is charging and the shutter cannot be released
	(Blinks slowly - after picture is taken) - Previous exposure was correct

QUICK OPERATION

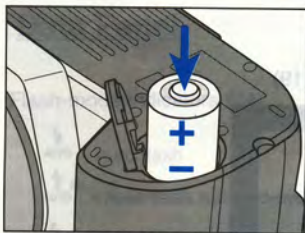

1. Insert batteries.

- This camera uses two CR2 lithium batteries.

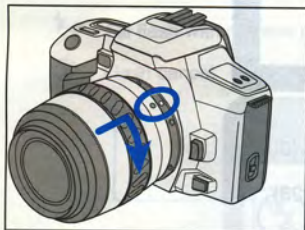

2. Attach lens.

- Align the red mounting dot on the lens with the one on the camera. Gently insert the lens into the mount and turn it clockwise until it clicks into the locked position.

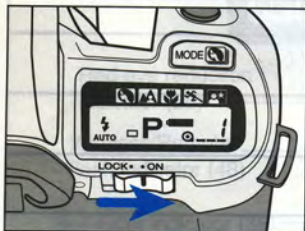

3. Turn on power.

- Slide the main switch to ON.

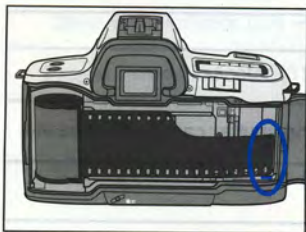

4. Load film.

- Align the film tip with the red mark, then close the back cover.

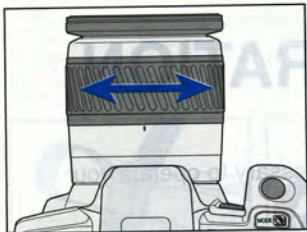

- 5** If using a zoom lens, rotate the zooming ring to frame your subject as desired.



- 6** Center your subject in the focus frame, then press the shutter release button partway down.

- The camera will focus and set exposure automatically.

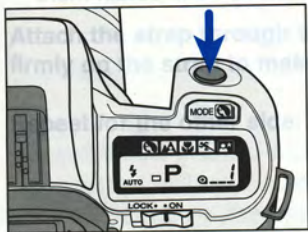

- 7** Take the picture.

- Gently press the shutter-release button all the way down to take the picture.

BASIC OPERATION

This section provides the information necessary to operate your camera in most photographic situations.

This section covers:

- Battery Installation
- Attaching and Removing the Lens
- Loading the Film
- Camera Handling
- Fully Automatic Camera Operation
- Special Focus Situations
- Basic Flash Operation
- Rewinding the Film

Once you fully understand the instructions in this section, proceed to Subject Program Selection and Additional Features to obtain more enjoyment from your camera.

ATTACHING THE STRAP

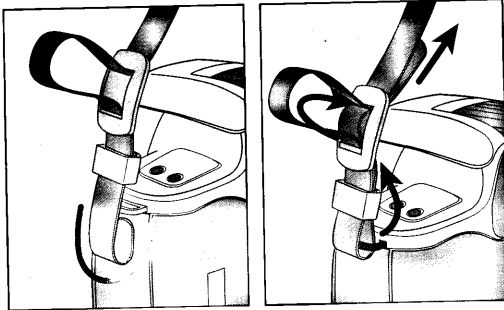

Attach the strap through the strap eyelets as shown. Pull firmly on the strap to make sure it is secure.

Repeat for the other side.

BATTERIES

Installing the Batteries

Your camera uses two 3V CR2 lithium batteries to supply power for all camera operations.

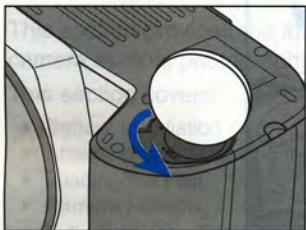

1. Using a coin or similar object, turn the battery-chamber lock to **OPEN**, then open the battery-chamber door.

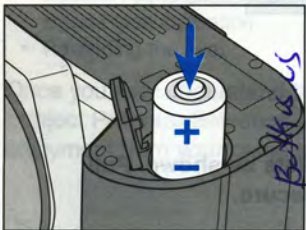

2. Insert the batteries as indicated by the + and - marks.

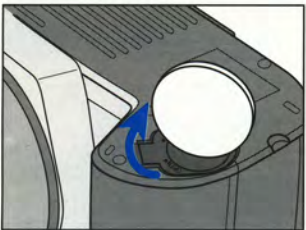

3. Close the battery-chamber door, then turn the battery-chamber lock to **CLOSE**.
 - Setting the camera down with the battery-chamber door open may damage the camera.

Checking Battery Power

Each time the main switch is set to ON, a battery symbol appears in the data panel indicating the power status of the batteries.



Full-battery symbol

Power is sufficient for all camera operations.

-  will only appear for five seconds.



Blinking low-battery symbol

Power is extremely low. All functions are operational, but the batteries will need to be replaced soon. Flash recycling time may be slow.

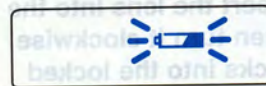

Blinking low-battery symbol appears alone and the shutter locks.

Power is insufficient for camera operation. Replace the batteries.

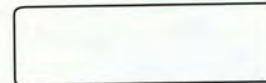

No display

Power is too low for the camera to operate. Replace the batteries or make sure they have been inserted correctly.

LENS

Attaching the Lens

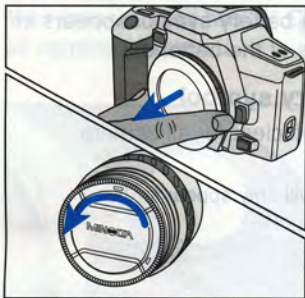

1. Remove the body and rear lens caps.

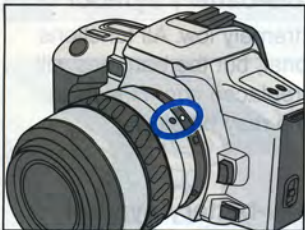

2. Align the red mounting dots on the lens and camera body.

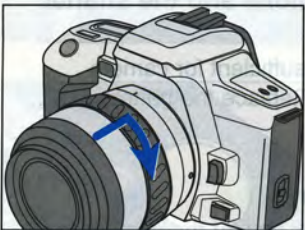

3. Gently insert the lens into the mount, then turn it clockwise until it clicks into the locked position.

- Do not insert the lens at an angle.
- Do not press the lens release when attaching the lens.

Caution

- Do not force the lens if it does not turn smoothly.
- Do not touch the inside of the camera, especially the lens contacts and mirror.

www.butkus.us

Removing the Lens

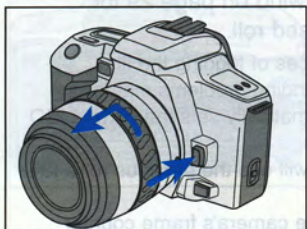

1. Press the lens release and turn the lens counter-clockwise until it stops.
2. Gently remove the lens and replace caps, or attach another lens.



LOADING FILM

Check the film window before loading film. If film is loaded, do not open the back cover. Refer to Manual Rewind on page 29 for instructions on removing a partially exposed roll.

- Load film in the shade to reduce the chances of fogging the film.
- Do not use Polaroid Instant 35mm film. Winding problems may occur.
- If DX-coded film is used, the camera automatically sets the correct ISO (film speed).
- If non DX-coded film is used, the camera will use the previous roll's ISO setting.
- Do not use infrared film in this camera. The camera's frame counter sensor will fog infrared film.

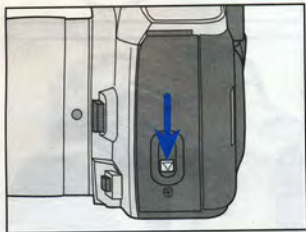

- 1. Slide the back-cover release down to open the back cover.**

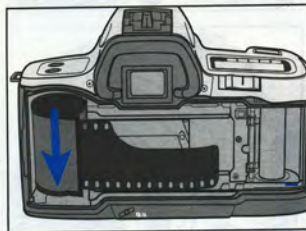

- 2. Insert a film cartridge into the film chamber.**

The shutter curtain's precision design makes it extremely sensitive to pressure. Never touch it with your fingers or the film tip.

www.butkus.us

shutter curtain

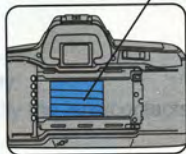

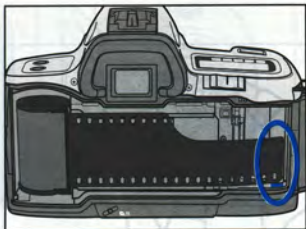

3. Extend the leader between the guide rails to the index mark.

- If the film tip extends beyond the index mark, push the excess film back into the cartridge.

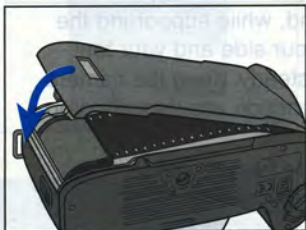
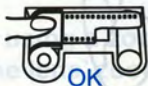

4. Close the back cover.

- The camera automatically advances the film to the first frame. 1 will appear in the frame counter.

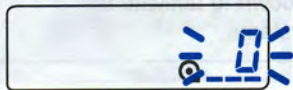

-  blinks in the frame counter and the shutter locks when the film is loaded incorrectly. Open the back cover and repeat steps 2 – 4.

If film is loaded with the power off

An  appear in the data panel for approx. five seconds to indicate successful loading, then the camera shuts down.

- If the film did not load,  will blink in the data panel before the camera shuts down. Reload the film.

HANDLING THE CAMERA

Holding the Camera



Grip the camera firmly with your right hand, while supporting the lens with your left. Keep your elbows at your side and your feet shoulder-width apart to hold the camera steady. Keep the camera strap around your neck or wrist in the event you accidentally drop the camera.

- Do not touch the end of the lens barrel while taking a picture.
- Use a tripod when using slow shutter speeds or a telephoto lens.

Pressing the Shutter-Release Button

Press the shutter-release button partway down to activate the camera's autofocus and auto-exposure systems.



Gently press the shutter-release button all the way down to take the picture.

TAKING PICTURES IN FULL AUTO

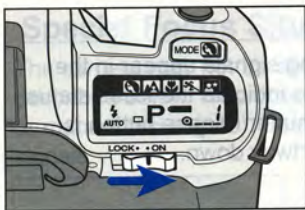

1. Slide the main switch to ON.

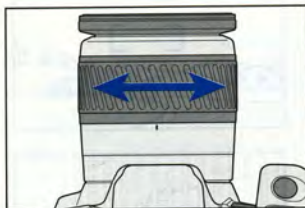

2. If using a zoom lens, rotate the lens' zooming ring to frame the subject as desired.



3. Center your subject in the focus frame [], then press the shutter-release button partway down to activate autofocus.

- ● or (●) will appear in the viewfinder when focus is confirmed.
- The built-in flash will pop-up and fire when necessary.

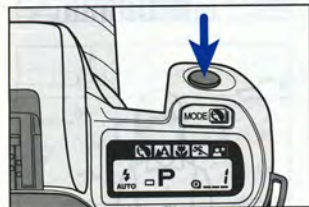

4. Press the shutter-release button all the way down to take the picture.

- In low-light conditions, the AF illuminator (flash) will fire to determine focus distance.
- Use focus hold (p22) if your subject is outside the focus frame.

Focus Signals



The following signals appear in the viewfinder to indicate the focus status when the shutter release button is pressed partway down.



Focus is confirmed



Continuous autofocus – **Focus is confirmed**



Focus cannot be confirmed – Shutter is locked.
Subject is too close or is one of the special focus situations described on page 21.

Special Focus Situations

The camera may not be able to focus in situations like those described below. When the focus signal blinks, use focus hold (p22) or manual focus (p45). See page 20 for an explanation of the focus signals.



If the subject within the focus frame is very bright, or low in contrast.



If two subjects at different distances overlap in the focus frame.

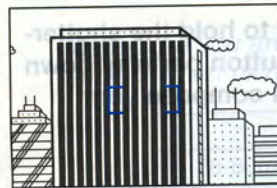

If a subject composed of alternating light and dark lines completely fills the focus frame.



If your subject is near a very bright object or area.

FOCUS

Focus Hold



Focus hold cannot be used for moving subjects.



Use focus hold when your subject is outside the focus frame or when autofocus is difficult to confirm.

1. **Center your subject in the focus frame, then press the shutter-release button partway down.**

- ● appears in the viewfinder when the focus is confirmed.
- Focus hold also locks the exposure settings.



2. **Continue to hold the shutter-release button partway down while you compose your picture.**

3. **Press the shutter-release button the rest of the way down to take the picture.**

- Remove your finger from the shutter-release button to cancel focus hold.



USING THE BUILT-IN FLASH

Flash Signals - (seen in the viewfinder)



Flash is charged.



(Blinks fast)

Flash is charging and the shutter can not be released.

After the picture has been taken.



(Blinks slowly)

Previous exposure was correct.

Flash Range

The range of the built-in flash depends on the speed of the film. Make sure your subject is within the flash range specified in the table below.

Make sure you are at least 1m (3.3 ft.) from your subject when using the built-in flash.

	LENS IN USE			
	28-80mm F3.5-5.6 II		35-80mm F4-5.6 II	
Film Speed	Wide angle	Telephoto	Wide angle	Telephoto
ISO 100	1.0 ~ 3.4 m (3.3 ~ 11.2 ft.)	1.0 ~ 2.1 m (3.3 ~ 6.9 ft.)	1.0 ~ 3.0 m (3.3 ~ 9.8 ft.)	1.0 ~ 2.1 m (3.3 ~ 6.9 ft.)
ISO 400	1.0 ~ 6.8 m (3.3 ~ 22.3 ft.)	1.0 ~ 4.2 m (3.3 ~ 13.8 ft.)	1.0 ~ 6.0 m (3.3 ~ 19.7 ft.)	1.0 ~ 4.2 m (3.3 ~ 13.8 ft.)

USING THE BUILT-IN FLASH

Changing the flash mode

When the flash mode button is pressed, the flash mode changes in the following sequence:

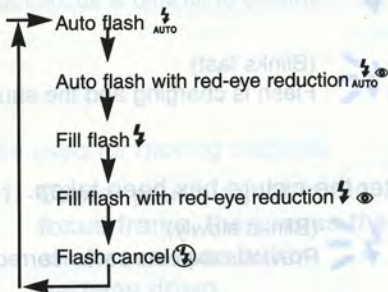
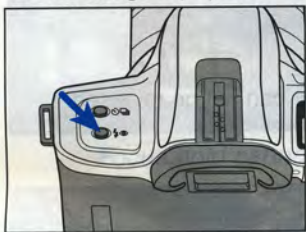

- The shutter will not release until the flash is charged.
- Select flash cancel (ⓧ) when you don't want the flash to fire.
- When you turn the main switch to ON, auto flash or auto flash with red-eye reduction will be set according to the setting used for the last picture taken.
- Make sure your subject is within the flash range specified in the table on page 23.

Auto Flash

In auto-flash, the built-in flash pops-up automatically when the shutter release button is pressed partway down in low light situations. Once the flash is up, it will fire when necessary.

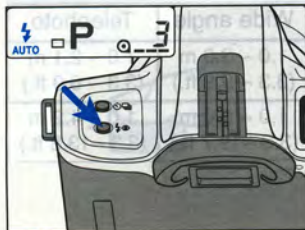

Press the flash mode button until  appears in the data panel.

www.butkus.us

Auto Flash with Red-Eye Reduction

Light reflecting from your subject's eyes may produce the effect known as red-eye. Use the built-in flash's red-eye-reduction mode to produce more natural looking photographs by reducing the red-eye effect.

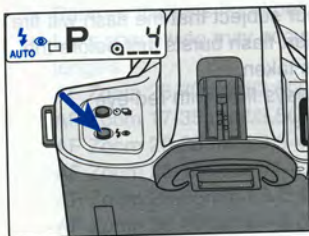

Press the flash mode button until ⚡ appears in the data panel.

- Warn your subject that the flash will fire a few short flash bursts just before the picture is taken.

Fill Flash

Use fill flash when taking pictures under fluorescent lighting or to eliminate harsh shadows. When set, the flash will fire every time a picture is taken. The TTL automatic flash metering system will ensure correct exposure.

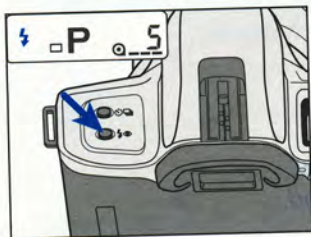

Press the flash-mode button until ⚡ appears in the data panel.

USING THE BUILT-IN FLASH

Fill Flash with Red-Eye Reduction

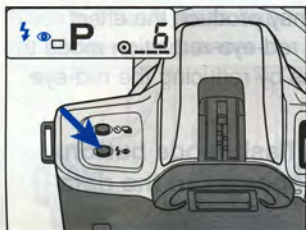



Press the flash-mode button until  appears in the data panel.

- Warn your subject that the flash will fire a few short flash bursts just before the picture is taken.
- Flash always fires with red-eye reduction.

Flash Cancel

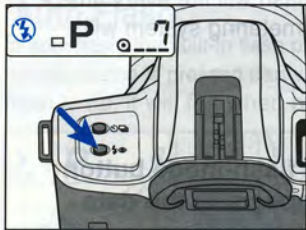
Use flash cancel when photographing twilight scenes or to capture the ambiance of existing light, or when flash is not permitted.



Press the flash-mode button until  appears in the data panel.

*The shutter speed may be slow.
Use of a tripod is recommended.*

www.butkus.us

Lens Shadowing

Lens shadowing occurs when the lens or lens hood blocks part of the output from the built-in flash. Lens shadowing appears as semi-circular shaded area at the bottom (horizontal) or side (vertical) of your image.

- Remove the lens hood before using the built-in flash.
- Lens shadowing may occur with the following lenses at shorter focal lengths.

AF Zoom 28-70mm f/2.8G

AF Zoom 17-35mm f/3.5G

AF Zoom 20-35mm f/3.5-4.5

AF Zoom 28-135mm f/4-4.5

AF Zoom 28-85mm f/3.5-4.5

AF Zoom 35-80mm f/4-5.6 II

- The built-in flash can not be used with the following lenses:
AF 300mm f/2.8 (APO tele)
AF 600mm f/4 (APO tele)

Do not use the built-in flash with focal lengths shorter than 28mm.
The built-in flash cannot cover focal lengths wider than 28mm.





REWINDING THE FILM

Automatic Rewind

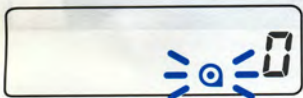
After you have exposed the last frame, the camera will automatically rewind the film. When the film is completely rewound, the motor will stop and  will blink in the data panel indicating it is safe to open the back of the camera.



1. Wait until the film is completely rewound.

-  will appear and  will blink in the data panel.

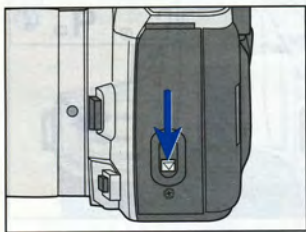

2. Slide the back-cover release down to open the back cover.

3. Remove the film, then close the back cover.

Manual Rewind

Use manual rewind to rewind the film before the current roll is finished.

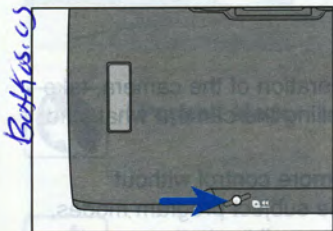

1. Press the manual-rewind button.
2. Follow steps 1-3 from Automatic Rewind.

SUBJECT PROGRAM SELECTION

Now that you are comfortable with the operation of the camera, take more control of the creative process by telling the camera what kind of picture you want to take.

The subject program modes let you take more control without leaving the automatic mode. In each of the subject program modes, the camera will automatically set the best possible shutter speed and aperture for the type of picture you are taking.

This section also lets you explore the use of the Self-timer and Continuous Advance modes.

Subject Program Selection	Page
Portrait Mode	32
Landscape Mode	33
Close-Up Mode	34
Sports Mode	35
Night Portrait Mode	36
Photographing Night Scenes	37

Drive Mode	Page
Self Timer	38
Continuous Advance	39

Each of these functions can be explored independently after basic operation has been mastered.

www.butkus.us

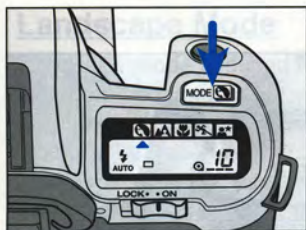

Press the subject program button to select any one of the following subject program modes. These program modes tell the camera what type of picture you will be taking so that it may customize the settings for that type of picture.



Portrait Mode - for portrait photography



Landscape Mode - for scenic and travel photography



Close-up Mode - for small subjects at close distances



Sports Mode - for sports and action photography



Night Portrait Mode - for night portrait and night scene photography

- Every time you turn the main switch to ON, the P (Program) mode is set and P appears in the data panel.

SUBJECT PROGRAM SELECTION

Portrait Mode

Portraits have the greatest impact when a shallow depth-of-field* is used to separate the subject from the background. In Portrait mode, the necessary settings are made automatically, leaving you free to capture the perfect expression.

- * Depth-of-field is the area in front of and behind the point you focused on that appears sharp.

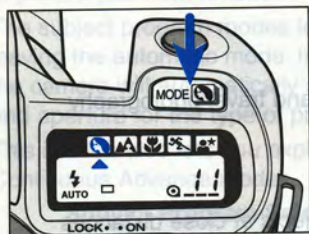

Press the subject-program button until the subject-program pointer is under .

Tips

- For best results use a mid-telephoto lens with a large aperture.
- Use flash when your subject is backlit or there are strong shadows across the face.
- Lock focus on your subject's eyes and be ready to capture the perfect expression.

Landscape Mode

Landscape mode is suited for photographing landscape, scenic or travel photographs. Landscape photography generally requires a large depth of field to make sure everything is in focus. In Landscape mode the camera is automatically set to the smallest aperture possible while maintaining a shutter speed fast enough to prevent blur due to camera shake.

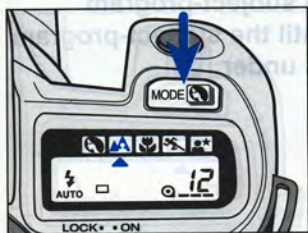

Press the subject-program button until the subject-program pointer is under .

Tips

- For best results zoom to a wide view or use a wide angle lens and include a foreground subject or detail to create a feeling of depth in the picture.
- Use flash when a subject in the foreground is backlit or has strong shadows across the face. If there is no subject in the foreground, do not use flash.
- Use a tripod, especially at slower shutter speeds.

SUBJECT PROGRAM SELECTION

Close-Up Mode

Choose the Close-Up mode when photographing small objects like flowers or jewelry. In Close-Up mode, the camera automatically sets the best possible aperture and shutter speed for the picture you are taking.

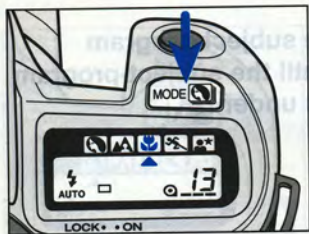

Press the subject-program button until the subject-program pointer is under .

Tips

- For best results use a macro lens or a macro capable zoom lens.
- Do not use the built-in flash if your subject is closer than 1.0m (3.3 ft.). The lens may block the flash, creating a shadow at the bottom of your image (lens shadowing, p27).
- Use a tripod to reduce camera shake.

Sports Mode

Fast shutter speeds are needed to stop action. In Sports mode, the camera will set the fastest possible shutter speed and continually adjust the focus to track fast-moving subjects.

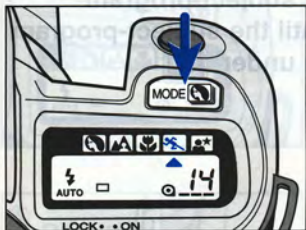

Press the subject-program button until the subject-program pointer is under .

Tips

- The built-in flash is only effective when your subject is within the flash range.
- Use fast film and keep the focus frame on your subject.
- Mount the camera on a tripod when using telephoto lenses.

SUBJECT PROGRAM SELECTION

Night Portrait Mode

Night portraits require the camera's flash exposure to be balanced with the background exposure. In Night Portrait mode, the camera sets the largest possible aperture with a longer shutter speed, allowing the background to appear in the photograph.



Press the subject-program button until the subject-program pointer is under .

Tips

- Be sure the camera is not set to flash cancel (⚡) when using Night Portrait mode.
- Use faster film and a tripod.
- Focus on the main part of your subject.
- Warn your subject not to move while the picture is taken.

Photographing Night Scenes

Cancel the flash in Night Portrait mode to photograph night scenes. The longer shutter speeds set in Night Portrait mode let you capture beautiful photographs of twilight scenes and night skylines.

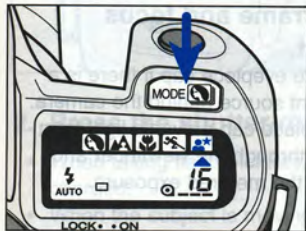

1. Press the subject-program button until the subject-program pointer is under .

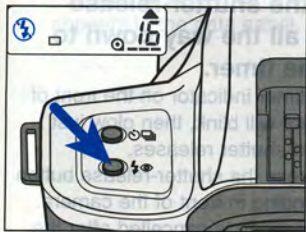

2. Press the flash-mode button until  appears in the data panel.

Tips

- Use faster film and a tripod.
- If you are photographing a dark night scene, it may be difficult for the camera to focus, use focus hold (p22) or manual focus (p45).

SELF-TIMER

The self-timer delays the release of the shutter for approximately 10 seconds after the shutter-release button is pressed.

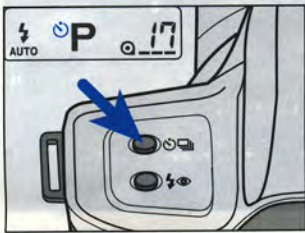

- 1. Place the camera on a tripod, then press the self-timer button until  appears in the data panel.**

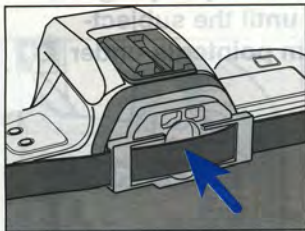

- 2. Center your subject in the focus frame and focus subject.**

- Attach the eyepiece cap if there is a bright light source behind the camera. The eyepiece cap prevents light from entering through the viewfinder and affecting the metered exposure.

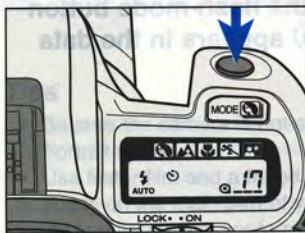

- 3. Press the shutter-release button all the way down to start the timer.**

- The self-timer indicator on the front of the camera will blink, then glow just before the shutter releases.
- Do not press the shutter-release button while standing in front of the camera.
- Self-timer mode is cancelled after the shutter is released.

Press the self-timer button or slide the main switch to lock to cancel the self-timer before the shutter releases.

www.butkus.us

CONTINUOUS-ADVANCE MODE

In this mode, the camera continues to release the shutter and advance the film as long as the shutter-release button is held down.

- AF Zoom xi and Power zoom lenses cannot be zoomed when continuous-advance mode is selected.

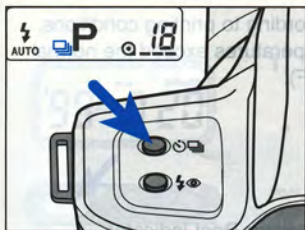

1. Press the drive-mode button until  appears in the data panel.

2. Press the shutter-release button down and hold.

- When taking flash pictures, the shutter will release after the flash is charged.
- When the subject is moving, the shutter will release after the camera focuses on the subject.
- To return to single frame mode, press the drive mode button until  appears in the data panel.

FOR OWNERS OF THE QUARTZ DATE MODEL

The Quartz-data function lets you record the date or time onto the lower-right corner of the photograph. The quartz data back has an automatic calendar through the year 2019.

- Imprinted data may be difficult to read if the lower-right corner of the photograph is bright or non-uniform.
- Imprinting size and position may differ according to printing conditions.
- Data imprinting may not be possible if temperatures exceed the normal operating range of 0 to 50 °C (32 to 122 °F).

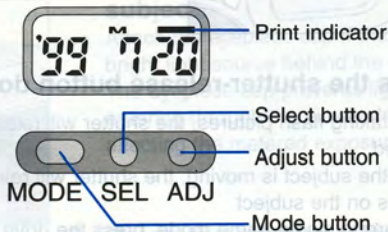

Exposing the Date/Time

Before taking the picture...

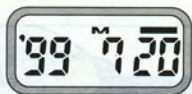

1. Press the mode button to choose the data imprinting format.

- The display changes as follows:



2. Take the picture.

- If the print indicator blinks after the shutter is released, the data was exposed.

FOR OWNERS OF THE QUARTZ DATE MODEL

Setting the Date/Time

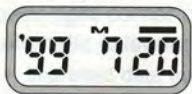

MODE SEL ADJ

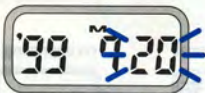

MODE SEL ADJ

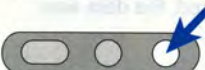

MODE SEL ADJ



MODE SEL ADJ

1. Press the mode button to choose the data imprinting format.

- M will appear above the month.

2. Use the select button (SEL) to move between different parts of the displayed data.

- The selected part will blink, indicating that it is the data to be changed.

3. Press the adjust button (ADJ) to change the data to the correct value.

- Data continues changing as long as the button is held down.
- In time mode, pressing the ADJUST button while : is blinking resets the seconds counter to zero (not shown).

4. When all data is correct, press the select button (SEL) until the data stops blinking.

Replacing the Battery

The quartz data back uses a CR2025 lithium battery, located on the inside of the back cover. Replace the battery if the display or imprinted data becomes dim.

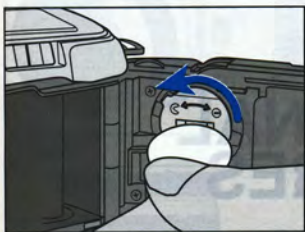

- 1. Open the back cover.**
- 2. Using a coin or similar object, turn the battery cover counter-clockwise, then remove it.**

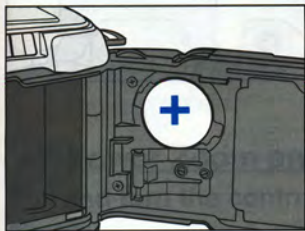

- 3. Remove the old battery and replace it with a new one.**
 - The + side should face up.
- 4. Replace the battery cover, then reset the date and time.**

ADDITIONAL FEATURES

MANUAL FOCUS

Focus the lens manually when autofocus is not suitable and focus hold is not possible. The autofocus system will monitor focus and indicate when a subject in the focus frame is in focus.

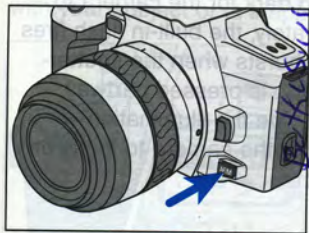

1. Press the focus-mode button. **M.FOCUS** will appear in the data panel.

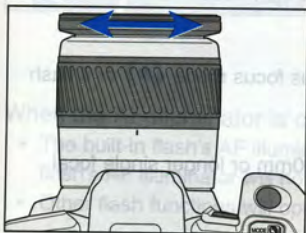
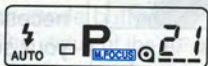

2. Turn the focusing ring until your subject appears sharp and focused.
 - ● appears in the viewfinder when the subject in the focus frame is in focus.
 - Press the focus-mode button again to return to the autofocus mode.

AF Power Zoom and xi-Series Lenses

Pull and turn the control ring until your subject appears sharp.

AF ILLUMINATOR

AF Illuminator (Built-in Flash) Function

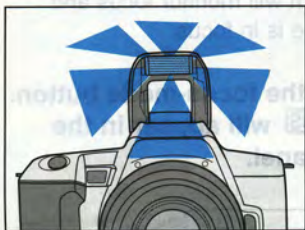

The AF Illuminator is a secondary function of the built-in flash. When the scene is too dark for the camera to focus accurately, the built-in flash fires a few short bursts when the shutter-release button is pressed partway down to provide the illumination necessary for the camera to focus on your subject.

- The range of the AF Illuminator flash is approximately one to five meters. (3.3 ~16.4ft.)
- The AF illuminator will not fire in continuous focus mode (●) or if flash cancel (⊕) is selected.
- The AF illuminator will not operate with 300mm or longer single focal length lenses.
- The AF illuminator will not operate with 3x-1x Macro Zoom.
- When an accessory flash is attached, its AF illuminator will be active in place of the camera's AF illuminator.

Canceling the AF Illuminator

You can cancel the built in flash's AF illuminator if it will interfere with your subject or is inappropriate.

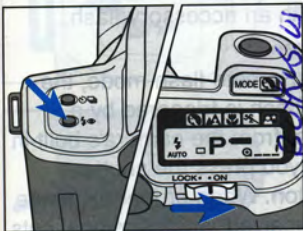

To turn the AF illuminator on or off, slide the Main switch to LOCK, then to ON while pressing the flash-mode button.

- The status of the AF illuminator is displayed in the data panel.

On - AF illuminator on

Off - AF illuminator off

When the AF Illuminator is cancelled;

- The built-in flash's AF illuminator will not fire, but an attached accessory flash's AF illuminator will not be cancelled.
- Other flash functions will operate normally.

WIRELESS/REMOTE FLASH



Normal Flash

Wireless/Remote Flash is available with the Minolta 5400HS, 5400xi, and 3500xi accessory flashes.

Wireless/Remote flash lets you experience the creative control available with an accessory flash.



Wireless/Remote Flash

In Wireless/Remote flash mode, the off-camera flash is triggered by a coded signal from the camera's built-in flash when you press the shutter-release button. When proper exposure has been received, another signal cuts the accessory flash off.

Taking Pictures in Wireless/Remote Flash Mode

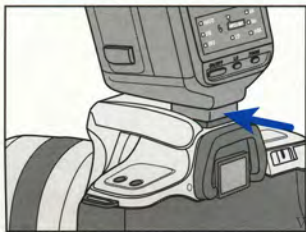

www.butkus.us



2. Press the flash mode button until WL appears in the camera's data panel.

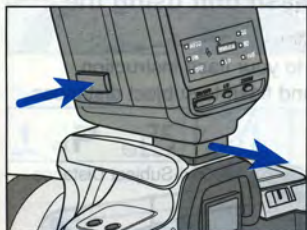

3. Detach the accessory flash, then press the camera's flash mode button to raise the built-in flash.

- See page 50 for positioning the camera, subject, and flash.

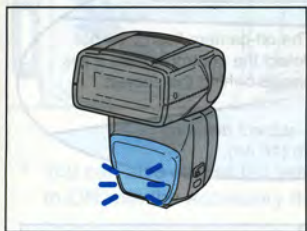

4. Wait until both flash units are fully charged.

- ⚡ appears in the viewfinder when the built-in flash is charged.
- When the off-camera flash is charged, its AF illuminator will blink.

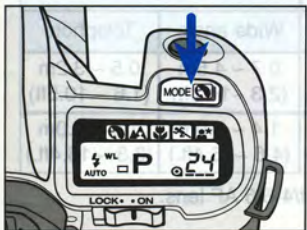

5. With the built-in flash up and WL showing in the data panel, press the subject program button to test fire the wireless/remote flash.

WIRELESS/REMOTE FLASH

- Press the shutter-release button all the way down to take the picture.

Positioning for Wireless/Remote Flash Mode

Position your camera and 3500xi flash unit using the information on this page.

- If you are not using the 3500xi flash, refer to your flash instruction manual for the correct camera to subject and flash to subject distances.

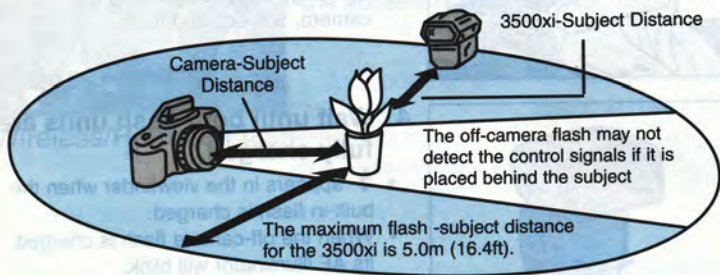

	Camera - Subject Distance		3500xi - Subject Distance	
Film speed	Wide Angle	Telephoto	Wide angle	Telephoto
ISO 100	1.0 ~ 5.0m (3.3 ~ 16.4ft.)	1.0 ~ 5.0m (3.3 ~ 16.4ft.)	0.7 ~ 4.5m (2.3 ~ 14.8ft)	0.5 ~ 3.2m (1.6 ~ 10.5ft)
ISO 400	2.0 ~ 5.0m (6.6 ~ 16.4ft.)	1.4 ~ 5.0m (4.6 ~ 16.4ft.)	1.4 ~ 5.0m (4.6 ~ 16.4ft.)	1.0 ~ 5.0m (3.3 ~ 16.4ft.)

- Chart data obtained using a 35-80mm f/4-5.6 AF lens.

www.butkus.us

Canceling Wireless/Remote Flash Mode

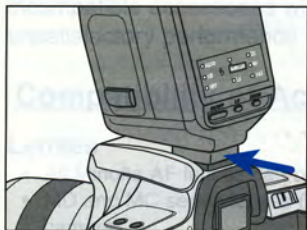

1. Attach the accessory flash to the camera.

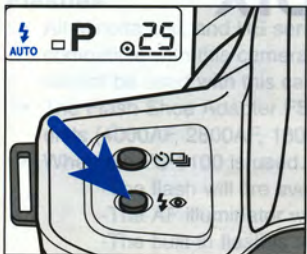

2. Press the flash mode button until WL no longer appears in the data panel.

- You can also cancel the wireless/remote flash by turning the main switch to ON with the accessory flash attached.

APPENDIX

ACCESSORY INFORMATION

This camera is designed to work specifically with lenses and accessories manufactured and distributed by Minolta. Using incompatible accessories with this camera may result in unsatisfactory performance or damage the camera and accessories.

Compatibility of Accessories

Lenses

- All Minolta AF lenses can be used with this camera.
- MD and MC series lenses (manual focus) cannot be used with this camera.

Flashes

- All Minolta i, si, and HS series flash units, and the Vectis SF-1 flash, are compatible with this camera. (High-speed syncro mode on HS flash cannot be used with this camera.)
- The Flash Shoe Adapter FS-1100 is required to mount AF series flash units (4000AF, 2800AF, 1800AF, and Macro flash 1200AF).
- When the FS-1100 is used...
 - The flash will fire every time the shutter is released.
 - The AF illuminator will not activate.
 - The built-in flash is set to fill flash when the accessory flash is removed.
- X, PX-series flashes and flashes sold by other manufacturers cannot be used with this camera.

Others

- The following accessories are not compatible with this camera:

Control Grip CG-1000	Data Receiver DR-1000
Creative Expansion Cards	Anglefinder
Magnifier	Wireless Controller IR-1N

ACCESSORY INFORMATION

Accessory Flash Control

When using an accessory flash, the desired flash mode can be controlled using either the camera or the flash.

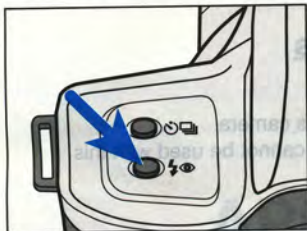

From the CAMERA

Press the flash-mode button to select the desired flash mode.

- The camera transfers data to the accessory flash immediately.
- Red-eye reduction cannot be selected when using an accessory flash.

- When an accessory flash is attached, pressing the flash mode button causes the flash modes to change in the following sequence.

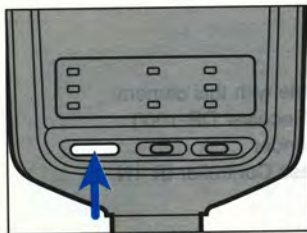
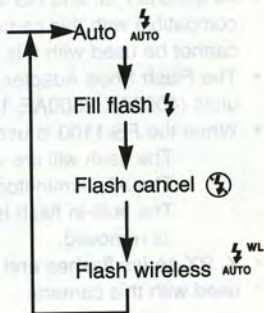

From the FLASH

Press the flash's ON/OFF button to select the desired flash mode.

- Data is not transferred from the flash until the shutter-release button is pressed partway down.
- Accessory fill flash cannot be selected.

For owners of the optional lens kits

Lens Hood

Flare is non-image forming light that degrades image quality. A lens hood improves image quality by reducing flare.

- Remove a lens hood before using the camera's built-in flash.

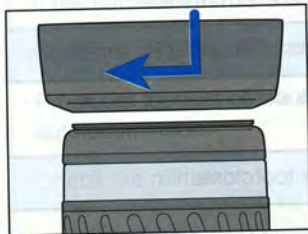

Fit the lens hood into the mount at the end of the lens barrel, then turn the hood clockwise until it stops.

- To store the hood, reverse it, attach it to the lens, then replace the lens cap.

Lens Specifications

AF Zoom 35 - 80mm f/4-5.6 II

Construction:	8 elements, 8 groups
Angle of View:	63° - 30°
Min. Focus Distance:	0.38m (1.25 ft.)
Mas. Magnification:	0.25X
Min. Aperture:	f/22-32
Filter Diameter:	49mm
Dimensions:	63 x 66mm
Weight:	150g (5.31 oz)

- Specifications are based on the latest information available at the time of printing and are subject to change without notice.

TROUBLE SHOOTING

Contact your nearest Minolta Service Facility if the following information does not cover the problem which you are experiencing or the condition continues.

PROBLEM	CAUSE
No display appears when the camera is switched on.	Batteries are loaded incorrectly.
	Batteries are exhausted.
Autofocus does not work when shutter-release button is pressed partway down.	Situation is unsuitable for autofocus.
	Camera is set to manual focus mode.
	Subject is too close.
Shutter cannot be released.	Focus cannot be confirmed.
	Camera is attached to a microscope or telescope.
Flash fires when the shutter-release button is pressed partway down.	The AF illuminator is on.
Flash picture is too dark.	Subject is beyond flash range.
Lower part of flash picture is dark.	Lens hood attached.
Err appears in the data panel.	Camera Malfunction.

www.butkus.us

Operating Temperature and Conditions

SOLUTION	PAGE
Remove and reinstall the batteries.	12
If the camera battery is exhausted, install a new battery.	12
Use focus hold or manual focus.	22/45
Press the focus mode button to return the camera to autofocus mode.	45
Check the minimum focus distance for your lens.	-
Use focus hold or manual focus.	22/45
Contact a Minolta service facility for information.	-
This is a normal camera operation. (The AF illuminator can also be cancelled.)	46
Make sure the subject is within the flash range.	23
Remove lens hood.	27
Remove and reinstall the batteries. If normal camera operation does not resume or the camera malfunctions repeatedly, contact an authorized Minolta Service Facility.	12

CARE AND STORAGE

Operating Temperature and Conditions

- This camera is designed for use from -20 to 50 °C (4 to 122 °F).
- Never leave your camera where it may be subjected to extreme temperatures such as the glove compartment of a car.
- Data panel response time will be slow at colder temperatures. The display will temporarily darken at higher temperatures, but will restore when the temperature normalizes.
- Never subject the camera to extreme humidity.
- To prevent condensation from forming, place the camera in a sealed plastic bag when bringing it from cold environment to a warm environment. Allow it to come to room temperature before removing it from the bag.
- The low-battery symbol may appear even with fresh batteries depending on the storage conditions. To restore camera power, repeat turning the camera on and off.
- Battery capacity decreases at colder temperatures. Keep your camera and spare batteries in a warm inside pocket when shooting in cold weather. Batteries will regain some of their capacity when warmed to normal operating temperature.

Storage

When storing your camera for extended periods,

- Always attach the protective caps.
- Store in a cool, dry, and well-ventilated area away from dust and chemicals such as moth balls. For long periods, place the camera in an airtight container with a silica gel drying agent.
- Periodically release the camera's shutter to keep it operating properly.
- Before using after prolonged storage, check the camera's operation to make sure it is functioning properly.

Cleaning

- If the camera or lens barrel is dirty, wipe it gently with a soft, clean, dry cloth.
If the camera or lens comes in contact with sand, gently blow away loose particles - wiping may scratch the surface.
- To clean the lens surface, first brush away any dust or sand then, if necessary, moisten a lens tissue with lens cleaning fluid and gently wipe the lens in a circular motion, starting from the center.
- Never place lens fluid directly on the lens.
- Never touch the interior of the camera, especially the shutter and mirror, doing so may impair their alignment and movement.
- Dust on the mirror will not affect the exposure but may affect the focus. Use a blower brush to remove dust from or around the mirror.
- Never use compressed air to clean the camera's interior, it may cause damage to sensitive interior parts.
- Never use organic solvents to clean the camera.
- Never touch the lens surface with your fingers.

Before Important Events

- Check the camera's operation carefully, or take test photographs.
- Minolta is not responsible for any loss that may occur due to an equipment malfunction.

Questions and Service

- If you have questions about your camera, contact your local camera dealer or write to the Minolta distributor in your area.
- Before shipping your camera for repair, please contact an authorized Minolta Service Facility for details.

SPECIFICATIONS

Camera Type: 35mm SLR with built-in flash, autoexposure (AE), and action predictive autofocus (AF)
Lens Mount: Minolta A-type bayonet mount
Viewfinder: SLR roof mirror type, 90% field of view
Magnification: 0.75X

Shutter

Type: Electronically-controlled, vertical-traverse, focal-plane type
Speeds: 30 sec. - 1/2000 sec.
Flash sync speed: 1/90 or slower
1/45 with wireless flash

Focus

Type: TTL phase-detection system, with one CCD sensor. Autofocus and manual focus modes.
AF Sensitivity Range: EV -1 to 18 (ISO 100)
AF Illuminator: Built-in with range of 1.0 - 5.0m. Automatically activated in low-light/ low-contrast situations.
AF Control: Single-shot, continuous, automatic AF-mode selection.

Exposure

Modes: P and 5 Subject Program modes (Portrait, Landscape, Close-up, Sports, Night Portrait)
Type: TTL metering; direct TTL metering for flash
Metering Cell: 2-segment SPC for ambient light and flash-metering SPC for flash.
Metering Range: EV 4 - 20
(ISO 100, f/1.4 lens)
Film-speed Setting: Automatic: ISO 25 to 5000 for DX-coded film.
Flash: ISO 25 - 1000.

Film Transport

Loading: Auto load

Drive Modes: Single frame, continuous advance
(1 frame/sec.), self-timer.

Rewind: Auto rewind, manual start (Count-down display)

Frame counter: Forward (shows number of exposures taken)

Built-in Flash

GN: 12 (ISO 100 in meters)

Coverage: 28mm angle of view

Recycling Time: Approx. 3 sec. (according to Minolta test methods)

Additional

Power: Two CR2 lithium batteries

Battery Performance:

Flash use (%)	Condition A		Condition B	
	20°C	-10°C	20°C	-10°C
0	40 rolls	30 rolls	65 rolls	50 rolls
50	17 rolls	13 rolls	23 rolls	18 rolls
100	11 rolls	8 rolls	14 rolls	10 rolls

• 24 Exposure rolls

Condition A: Lens (35-80 f/4-5.6) focused from infinity to 2m three times and the shutter-release button held partway down for ten seconds before each exposure.

Condition B: Lens (35-80 f/4-5.6) focused from infinity to 2m and the shutter-release button held partway down for five seconds before each exposure.

- Battery performance will vary with usage conditions.
- Exposures taken at a rate of 2 rolls/month.

Dimensions : 135.0 x 90.0 x 58.5mm (WxHxD)
QD model: 135.0 x 90.0 x 61.0mm (WxHxD)

Weight : 340g (w/o camera battery)
QD model: 355g (w/o camera battery)

Specifications and accessories are based on the latest information available at the time of printing and are subject to change without notice.

Minolta Co., Ltd.

Minolta Europe GmbH

Reparatur/Repair

Minolta France S.A.

Minolta (UK) Limited

Minolta Austria Ges. m.b.H.

Minolta Camera Benelux B.V.

Belgium Branch

Minolta (Schweiz) AG

Minolta Svenska AB

Finland Branch

Minolta Portugal Limitada

Minolta Corporation

Head Office

Los Angeles Branch

Minolta Canada Inc.

Head Office

Vancouver Branch

Minolta Hong Kong Limited

Minolta Singapore (Pte) Ltd.

Shanghai Minolta Optical

Products Co., Ltd.

3-13, 2-Chome, Azuchi-Machi, Chuo-Ku, Osaka 541-8556, Japan

Minoltaring 11, D-30855 Langenlagers, Germany

Senator-Helmken-Strasse 1, D-28197 Bremen, Germany

365 Route de Saint-Germain, F-78420 Carrières-Sur-Seine, France

7 Tanners Drive, Blakelands, Milton Keynes, MK14 5BU, England

Amalienstrasse 59-61, A-1131 Wien, Austria

Zonnebaan 39, P.O. Box 6000, NL-3600 HA Maarssen, The Netherlands

Prins Boudewijnlaan 1, B-2550 Kontich, Belgium

Riedstrasse 6, CH-8953 Dietikon, Switzerland

Albygatan 114, S-171 54 Solna, Sweden

Niittykatu 6 PL 37, SF-02201 Espoo, Finland

Av. do Brasil 33-A, P-1700 Lisboa, Portugal

101 Williams Drive, Ramsey, New Jersey 07446, U.S.A.

11150 Hope Street Cypress, CA 90630, U.S.A.

369 Britannia Road East, Mississauga, Ontario L4Z 2H5, Canada

230-3771 Jacombs Road, Richmond, B.C. V6V 2L9, Canada

Room 208, 2/F, Eastern Center, 1065 King's Road, Quarry Bay, Hong Kong

10, Teban Gardens Crescent, Singapore 608923

368 Minolta Road, Songjiang, Shanghai, China

© 1999 Minolta Co., Ltd. under the Berne
Convention and Universal Copyright Convention