



This manual is for reference and historical purposes, all rights reserved.

This page is copyright© by M. Butkus, NJ.

This page may not be sold or distributed without the expressed permission of the producer

I have no connection with any camera company

On-line camera manual library

This is the full text and images from the manual. This may take 3 full minutes for the PDF file to download.

If you find this manual useful, how about a donation of \$3 to: M. Butkus, 29 Lake Ave., High Bridge, NJ 08829-1701 and send your e-mail address so I can thank you. Most other places would charge you \$7.50 for a electronic copy or \$18.00 for a hard to read Xerox copy.

This will allow me to continue to buy new manuals and pay their shipping costs.

It'll make you feel better, won't it?

**If you use Pay Pal or wish to use your credit card,
click on the secure site on my main page.**

B-425
SERIAL-E-207
MODEL-A

IM-400-A424-1
INSTRUCTION MANUAL
11-1-60 Issue 3

2019
2022

ascorlight®



Electronic Flash

Instruction Manual

for

- | | |
|------|------|
| A412 | B413 |
| A414 | B415 |
| A420 | B416 |
| A424 | B421 |
| A425 | |
| A426 | |
| A429 | |

*Brooks Camera Co.
45 Keating -
EX-2-1902*

MANUFACTURED IN U. S. A.

BY

AMERICAN SPEEDLIGHT CORPORATION

63-01 METROPOLITAN AVENUE
MIDDLE VILLAGE 79, N. Y.

TABLE OF CONTENTS

	Page
1. Preface - Welcome to Ascortlight Family.	i
2. Ascort Guarantee.	ii
3. Foreword - Boiling the Mystery out of Speedlight	1
4. GENERAL DESCRIPTION - Series 400.	7
4.1 Description Model A412	8
4.2 Description Model A414.	9
4.3 Description Model A420	11
4.4 Description Model A424 and A425.	13
4.5 Description Model A426	15
4.6 Description Model A429	17
4.7 Description Model B413	18
4.8 Description Model B415	20
4.9 Description Model B416	21
4.10 Description Model B421	22
5. Operating Instructions - Series 400.	23
5.1 Assembly - Series 400.	23
5.2 OPERATION.	23
5.3 Lectro-Sync Operation	23
6. PHOTOGRAPHIC AND TECHNICAL DATA	26
6.1 Technical Data	26
6.2 Synchronization.	26
6.3 Light Data.	27
6.3.1 BCPS Values for Combination of Light Units & Power Supplies	27
6.4 Exposure and Guide Numbers	28
6.5 Ascort Guide Number Nomograph For Electronic Flash	29
6.6 Development	30
7. CARE AND MAINTENANCE.	30
8. SERVICE.	31
8.1 CHECKING PROCEDURES	31
8.2 Fuses.	32
8.3 Flash Tubes Used With Series 400.	32
9. AUXILIARY EQUIPMENT, ACCESSORIES & PARTS	32



Welcome to the ascorlight Family

We, the designers and manufacturers of your new ASCORLIGHT, take this opportunity to congratulate you on your selection. We are confident that this purchase of your ASCORLIGHT unit will result in your being another member of the large family of satisfied ASCORLIGHT users.

ASCOR has long stood for the best in electronic flash. The Company (starting as Parker & Young and the trademark Fotolux in 1946, changing to American Speedlight Corporation in 1948) has, from the beginning, specialized in building the most advanced types of speedlights for exacting professionals.

We realize that you, as a satisfied user, will be one of our most valuable assets and potentially one of our best salesmen. Therefore, we have prepared this manual to acquaint you with and assist you to get the most out of the advantages which we have built into your ASCORLIGHT.

Since your particular application may be somewhat different from that of others, it is difficult to include enough general information to help solve all varied problems. We invite you to write us about your particular problems, questions, complaints or suggestions. Together, through an active exchange of ideas, we can all learn to use today's equipment more effectively, and plan tomorrow's equipment more intelligently.

To help us know you and meet our obligations to you, please fill out and mail the enclosed registration-guarantee card now. It will put your guarantee into effect and enable us to periodically send you the most up-to-date information on the application of ASCOR equipment - equipment we are proud to sell, and you will be proud to use.

Sincerely,

AMERICAN SPEEDLIGHT CORPORATION

2. **ascor** GUARANTEE

All ASCOR equipment, when properly registered is guaranteed against defects in material and workmanship for a period of ninety (90) days, provided it has not been subjected to abnormal usage.

Special components, such as nickel cadmium batteries, lead acid batteries and capacitors (see guarantee card) are guaranteed for longer periods.

Under this guarantee, our obligation is limited to repairing or replacing the equipment at our option, provided it is returned, prepaid, to the factory. This does not include batteries or tubes.

This guarantee is in lieu of all other guarantees, implied or expressed, and no representative or person is authorized or allowed to assume for the American Speedlight Corporation any obligations not in accordance with the above.

This guarantee does not apply to any instrument which has been tampered with in any way, or which has the Serial number removed, altered or effaced.

IMPORTANT

This guarantee is not valid until the registry card has been returned to American Speedlight Corporation, 63-01 Metropolitan Avenue, Middle Village 79, N.Y. MAIL AT ONCE.

3. FOREWORD

Boiling the Mystery Out of Speedlighting

By HARRY L. PARKER, Pres. American Speedlight Corp.
Printed in *Photographic Trade News*, May 1955.

The tremendous number of speedlights (electronic flash) in all shapes, sizes, and prices that have been, are and will be on the market, sometimes leaves even the electronic flash engineer confused. With all the claims, counter-claims, and partial information, a few simple facts that can be used as a basis of comparison or evaluation are needed.

The typical first approach to speedlights is to use guide numbers and let it go at that. However, there are two serious faults in using guide numbers. First, high guide numbers can be achieved by concentrating the available light in a narrow beam from the reflector. The result, however, is uneven coverage or "hot spots". Second, with a given speedlight, guide numbers can be honestly chosen over a very wide range. In black and white, depending on the film, method of development, latitude of film, etc., guide numbers of 6 to 1 could be chosen. One could have the film go through standard photo finishing, but even here there is a wide latitude, particularly with some of the new film.

Even with color film, it is well known that variations in processing can give changes of over plus-or-minus one full f/stop. This would mean a difference in guide numbers of 2 to 1.

Kodachrome, with its standardized processing, has been suggested as the basis for color guide numbers. Even here, the conditions of taking and viewing can result in good photographers giving guide numbers of about one stop difference. Let's say that a manufacturer gives a "middle of the road" Kodachrome guide number of 40. On the test strip using all f/stops, it is common for qualified photographers to choose exposures that give guide numbers ranging from 35 to 56.

The point is this - - don't get too excited or misled by a small numerical difference in guide numbers. Most of you have heard heated discussions over color guide number differences of only 10% to 15%. The chances are that ratings of, say 40 or 45, represent an honest difference of opinion of the persons selecting the 'best'. Both could be within the range of acceptability.

IMPORTANT RATINGS

For too long most people have rated speedlights in watt seconds. Just what is a watt-second? If you really know, you are one of the unusual photographers. Then again, what photographer really cares? Watt-seconds is not a rating of light output of speedlight equipment. The use of watt-seconds, microfarads, and other terms have so confused the photographer that many are thoroughly baffled about electronic flash.

Speedlight has already established itself as a major photographic light source and will continue to grow in spite of this confusion. If we consider for a moment the purpose of speedlight, we realize that its whole function is to produce light of proper quality to take pictures. When you get down to basic factors, the points of comparison should be:

- (1) Photographic effectiveness of the light
- (2) Operational requirements
- (3) Dependability
- (4) Cost

Speedlight is just light. It can be used with the same photographic lighting effect as any other type of light source. It has daylight quality, and is constant, cool and clean). It can be emphasized that this gives a daylight source that can be controlled any time, anywhere. The points that determine the photographic effectiveness and what the photographer needs to know about any light source are:

- (1) Strength of light
- (2) Color of light
- (3) Coverage of the reflector
- (4) Speed of the flash or exposure

In addition to these, the user of a speedlight also needs to know the recharge or recycling time of his equipment.

Knowing these things is important, provided a standard term and method of measuring is used in arriving at the figures. The need for establishing standards for electronic flash has been recognized by many of the leaders in photographic engineering, and a project was set up by the Committee on Standards of the Society of Photographic Engineers. A questionnaire was sent out to a large number of people concerned with electronic flash and the answers were collated. The definitions agreed upon by the majority were collated. The definitions agreed upon by the majority of those replying were written up as proposed standards, and the intention of the S.P.E. Committee on Standards was, and is, to submit the results of this survey to the American Standards Association for their consideration.

The results of the survey, the general agreement that came out of it, and the fact that many of the speedlight manufacturers are now giving data based on these definitions, indicate that these definitions and terms may well become standard by common usage. The definitions agreed to by the majority are:

STRENGTH OF LIGHT AND COVERAGE

The recognized unit of measure for the strength of a light source is the candle power. Photographically, we are concerned not only with the strength of the light but also the time. The sum of the light energy, during a period of time, is therefore measured in candle power seconds (equivalent to the light of one candle power strength acting for one second's time). When measuring a light source on the beam of the reflector, the term is referred to as Beam Candle Power Seconds (abbreviated B.C.P.S.).

It is possible to concentrate all the available light on the beam and get a very high rating or guide number on the beam but have an unusable "hot spot". In recognizing this, the first approach in standardizing definitions required that measurements be averaged over a specified zone and the resulting average was referred to as Effective Candle Power Seconds (E.C.P.S.). This proved to be somewhat cumbersome and difficult to measure in the field.

The current thinking is that the rating for lighting effectiveness be included in one rating which will give both the strength of the light and the coverage. Such a rating applies only to reflectors which have a smooth coverage with no objectionable "hot spots". This rating gives the Beam Candle Power Seconds (BCPS) and the Angle of Coverage and is shown as follows: 2000 BCPS/60°. This means 2000 Beam Candle Power Seconds as measured on the beam or axis of the reflector and a coverage of 60 degrees as defined below. Numerically, on a good type reflector, the BCPS will be different from previously measured ECPS by only about 10% more. Therefore data still giving BCPS can be used for your starting tests.

SPEEDLIGHT POINTERS

Make sure you know the strength of light, reflector coverage and flash speed.

Then compare similar units.

Base dependability on your experience, the unit's reputation and the manufacturer's guarantee.

Compare prices, considering factors such as flexibility, synchronization, etc., that add value without greatly increasing cost.

The light output of a speedlight unit is measured by a meter such as the General Radio Integrating Light Meter that has been calibrated against a standard light source.

COVERAGE OF REFLECTOR

Coverage is measured by rotating the light on a compass with the light meter fixed. Half angle is the point where light falls off to 1/2 of that on the beam. (Fig. 1.) This point is called the 1/2 power point.

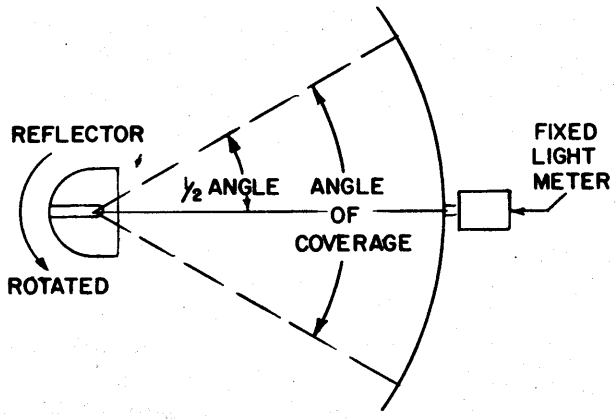

FIGURE 1
COVERAGE
OF
REFLECTOR

METHOD OF MEASURING REFLECTOR ANGLE

Half angle defined as angle where light is $\frac{1}{2}$ of light on axis.

SPEED OF FLASH

Defined as length of time between the times when the intensity of the light is more than $1/3$ of the peak intensity. This helps evaluate the action-stopping ability and the reciprocity failure effect in the film (Fig.2).

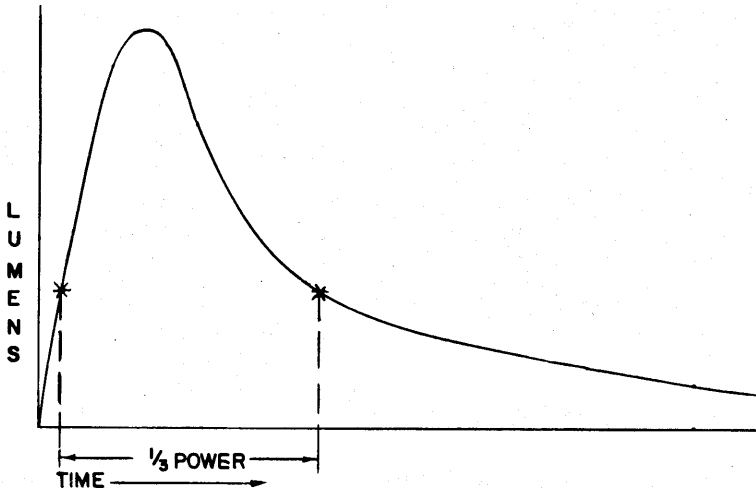

TYPICAL FLASH DISCHARGE CURVE

Duration of flash measured between $1/3$ power points.

Figure 2

COLOR

Most electronic flash units are of about the same color characteristics. Don't be confused by claims of a few hundred degrees difference in Kelvin temperature. Kelvin ratings are approximate comparisons and the flash cannot be compared accurately to "black body radiation". Most speedlights are of daylight color quality and slight filtering may be required for daylight color materials, depending on the emulsion

RECHARGE TIME

Defined as the time required to recharge the capacitors to 90% of their peak voltage. This determines the recycling time that can be used with even exposures. (Fig. 3).

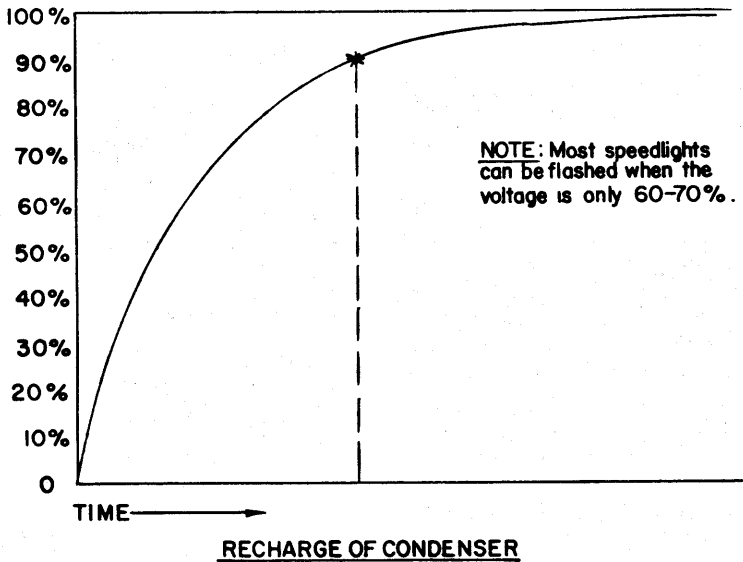

Figure 3

Most of the small units are one-light portables aimed at the amateur. However, there are speedlights available that can provide any number of lights, of almost any power, at fast rates of flashing, etc. Be sure to obtain the proper equipment to do the job that you want photographically.

DEPENDABILITY

Everybody claims dependability. Electronic equipment can be very dependable if properly engineered. It would be very difficult to give any rules to guide a customer on judging dependability. It looks, therefore, like the customer must use judgement about a manufacturer's reliability and integrity, plus the service and guarantee that backs up the unit.

All sales get down to price. We all say that "you can't get something for nothing", yet we all try for a lower price and discount. Remember, unless the cheapest price gives the photographic results that are wanted, plus dependability and proper operation, then no matter how little is paid, it is a waste of money.

If we start talking about speedlight in terms of light output, with the other qualifying factors, such as the duration of the flash and the angle of coverage of the reflector, these terms will become common and easy as we get used to them. It will help the entire Photographic Industry if we can "Boil the Mystery Out of Speedlight, reduce the important factors to simple terms, so that speedlight or electronic flash will be considered technically no more difficult than f/stops.

4. GENERAL DESCRIPTION - Series 400

The Series 400 ASCORLIGHTS are portable, lightweight, heavy duty, professional speedlights. A wide range of power supplies, light units, and accessories make it possible to adapt the equipment for many applications. Since both the Series 400 and Series 500 operate at the same voltage (900 volts, 450 volts each side of chassis ground) and have the same type of circuitry, all parts of these two Series are interchangeable. The Series 400 includes both high powered battery operated portables and AC operated units for location work.

The ASCOR SPEEDLIGHTS are electronic devices for converting electrical energy from a relatively small power source into a high-speed, high-intensity flash of light. Essentially, the energy is drawn slowly from the power line or battery, converted into high voltage, and stored in a capacitor (an electrical storage tank). Then at the moment the flash of light is desired, the energy (watt-seconds) is dumped instantaneously out of the capacitors through the flash tube which converts the electrical energy into light.

Speedlight is cool, clean, fast, of daylight quality, efficient, and economical.

IMPORTANT FEATURES OF THE ASCORLIGHT Series 400

The ASCORLIGHT Series 400 AC operated units include many outstanding features of design and engineering. A few of these are:

- (1) High light output.
- (2) Short recharging time of capacitors.
- (3) Light-weight power supplies.
- (4) Efficient, broad, even coverage reflectors.
- (5) Interchangeable reflectors - choice of 10", or 16".
- (6) Provides sensitivity for phototube (slave) operation.
- (7) Thyatron trigger tube circuit that protects shutter contacts.
- (8) Adequately fused circuits.
- (9) Wide range of ASCOR auxiliary light units and accessories permits addition of extra lights.
- (10) Heavy-duty connectors.

4.1 DESCRIPTION - MODEL A412

HEAVY DUTY THREE LIGHT ASSEMBLY (200-100-100 W-S)

The A412 is a 400w-s assembly designed for three light color work. The power is divided so that the photographer has 200 w-s on his main light, and 100 w-s on each of the other two lights. Each light outlet is isolated and the modeling lamps are in the same 2-1-1 ratio as the flash-tubes. Each light outlet on the power supply is controlled by a separate switch so that it can be operated independently from the others.

The power supply is also equipped with a light output meter showing the extent to which the condensers are charged. This aids the photographer in assuring the same amount of light on each exposure.

The AL424B 10" Light Units are normally used, but any choice of Series 400 or Series 500 lights can be used.

INCLUDES:

- 1-B412 Power Supply
- 1-D501 Power Cord
- 1-K107 Sync Cord
- 3-L424B Light Units
- 3-P602 10" Reflectors
- 3-F517 Flash Tubes
- 9-F108 60 Watt Modeling Lamps

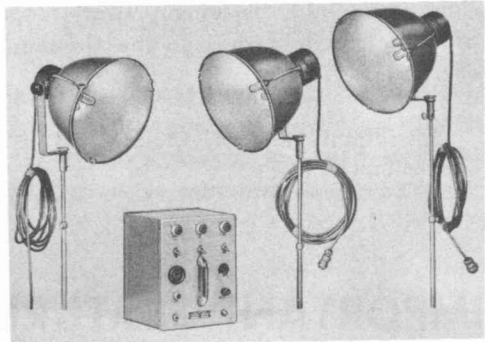

A412

Figure 4

SPECIFICATIONS

LIGHT OUTPUT: 8,000 BCPS/55° (200 w-s main light)

WATT-SEC.: 400 (200-100-100)

GUIDE NO.: Ektacolor Type S 110; ASA 125 B&W 240

RECYCLE TIME: 8 sec.

SPEED OF FLASH: 1/2000 sec.

VOLTAGE INPUT: 105-125 volts, 50-60 cycles AC

POWER INPUT: 550 watts maximum with modeling lights

FUSE VALUE: 2 amp Slo-Blo type MDL

SIZE: 8¼" Wx9 "Lx10¼"H

WEIGHT: 20 lbs.

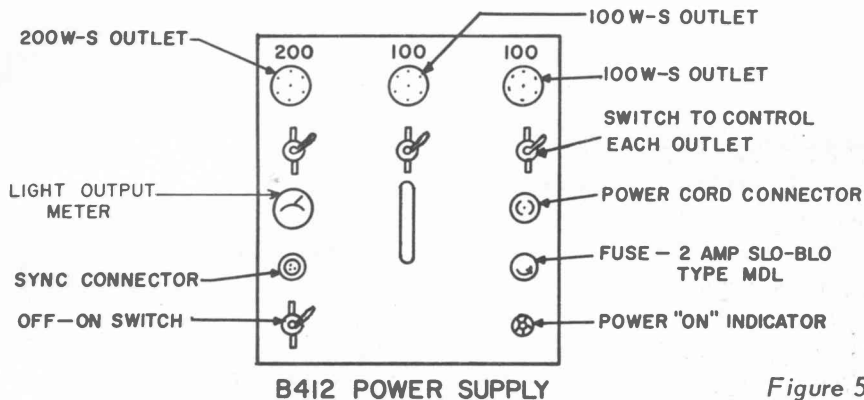

Figure 5

SPECIAL OPERATING INSTRUCTIONS - B412 POWER SUPPLY

1. Connect light units to proper connectors on power supply.
2. Connect K-107 sync cord to sync outlet on power supply. Attach shutter sync cord from camera to K-107 cord.
3. Insert power cord into 117 volt 60 cycle line of 550 watts minimum capacity. (15 amp circuit)
4. Turn on power switch and desired outlet switch and operate unit.

4.2 DESCRIPTION MODEL A414

HEAVY DUTY SINGLE LIGHT ASCORLIGHT

The power supply in this assembly attaches to a light weight stand, and is extremely simple to operate. The power and sync cords to the automatic camera are in one cable. Excellent for applications such as Santa Claus production work, identification pictures, or any other work requiring one light cable of continuous operation every 3 sec.

Figure 6

INCLUDES:

- 1-B414 Power Supply
- 1-L419-15 Light
- 1-F118 50 watt Modeling Lamp

A414

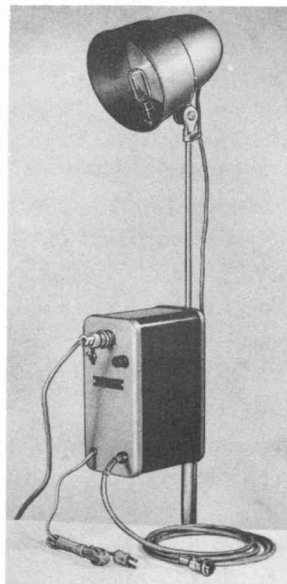

SPECIFICATIONS

LIGHT OUTPUT: 2000 BCPS/38°

WATT SEC.: 60

GUIDE NO.: Ektacolor Type S-56; ASA 125 B&W - 125

RECYCLE TIME: 2 sec.

SPEED OF FLASH: 1/3000 sec.

VOLTAGE INPUT: 105-125 volts, 50-60 cycles AC

POWER INPUT: 100 watts maximum with modeling lights

FUSE VALUE: 1 amp. Slo-Blo MDL

SIZE: Power Supply - 6" Lx3½ "Wx5"H

WEIGHT: 3½ lbs.

SPECIAL INSTRUCTIONS - B414 POWER SUPPLY

Power Supply

The power supply comes completely assembled and requires only interconnection to voltage source and light unit to operate.

Fig. 7 shows the layout of the connectors and controls. A brief description follows:

Light Connector

Light unit connects here.

Power-On Light

Glowes when power is ON

H.V. Light

Glowes when H.V. is up.

Power

ON-OFF toggle for turning unit ON and OFF.

Sync

Connection for synchronizing flash with camera shutter. Attach sync cord here.

Fuse

1 amp. Slo Blo

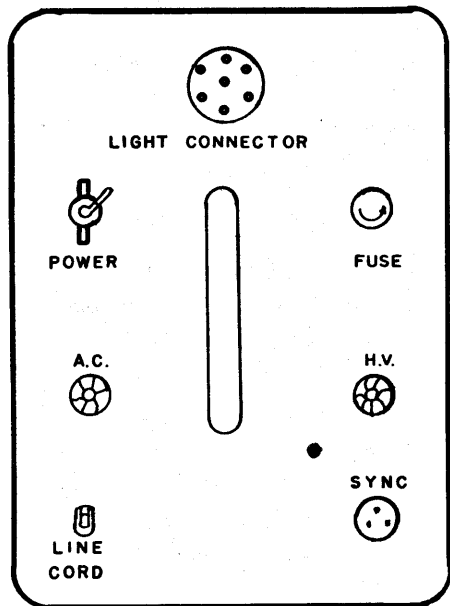

B414 POWER SUPPLY

Figure 7

OPERATING INSTRUCTIONS:

1. Connect AN type connector from the light unit to connector on power supply.
2. Plug AC cord into 117 volt, 60 cycle power outlet.
3. Push power toggle to ON. Power light will glow.
4. Plug in and tighten sync cord. Connect Jones plug to female connector of camera sync cord.
5. Unit is ready to Operate.

CAUTION: Turn power Off and flash the unit before removing flash tube or light.

4.3 DESCRIPTION MODEL A420

A420 HEAVY DUTY 200 WATT-SEC. SINGLE LIGHT

This unit is designed especially as a heavy duty, dependable, simple to operate, high powered unit for single light color work such as Christmas Santa Claus pictures. It combines maximum light output with dependability and economy.

INCLUDES:

- 1-B420 Power Supply
- 1-L424B Light Unit
- 1-F517 Flash Tube
- 3-F108 60 watt Modeling Lamps
- 1-K107 Sync Cord

SPECIFICATIONS

LIGHT OUTPUT: 8,000 BCPS/55°

WATT-SEC.: 200

GUIDE NO.: Ektacolor Type S 110; ASA 125 B&W 240

RECYCLE TIME: 6 sec.

SPEED OF FLASH: 1/1500 sec.

VOLTAGE INPUT: 105-125 volts 50-60 cycle AC

POWER INPUT: 400 watts maximum with Modeling Lamps.

FUSE VALUE: 1 amp. Slo-Blo MDL

SIZE: Power Supply: 10" Lx4½" wx6½"H

WEIGHT: 10½ lbs.



A420

Figure 8

SPECIAL INSTRUCTIONS FOR B420 POWER SUPPLY

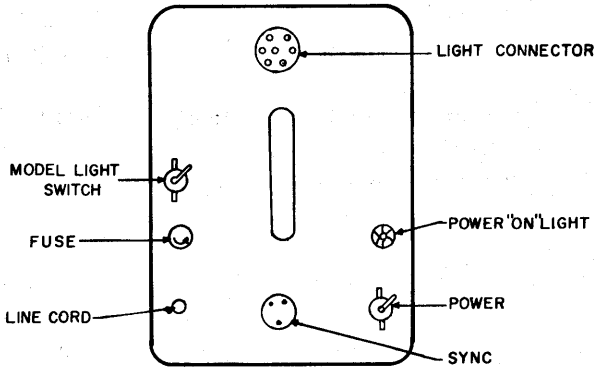

Figure 9

B420 POWER SUPPLY

Assembly Instructions:

Power Supply

The power supply comes completely assembled and requires only inter-connection to voltage source and light unit to operate.

Fig. 1 shows the layout of the connectors and controls. A brief description follows:

Light Connector

Light unit connects here.

Power-On Light

Glows when power is ON.

Power

ON-OFF toggle for turning unit ON and OFF.

Model

ON-OFF toggle for turning model light ON and OFF.

Sync

Connection for synchronizing flash with camera shutter. Attach sync cord here.

Fuse

1 amp. Slo Blo

Operating Instructions:

1. Connect AN type connector from the light unit to connector on power supply.
2. Plug AC cord into 105-125 volts, 50-60 cycles AC.
3. Push power toggle to ON. Power light will glow.
4. Plug in and tighten sync cord. Connect Jones plug to female connector of camera sync cord.
5. Unit is ready to operate.

CAUTION: Turn power off and flash the unit before removing flash tube or light unit.

L-434
ASCOR LIGHT

4.4 DESCRIPTION

MODEL A424 & A425

A424 - A425 HEAVY DUTY FOUR LIGHT AC ASSEMBLIES
(100-100-50-50 W-S)

The A424 is a 300 W-S assembly designed for heavy duty, economical operation for four-light portraiture. Two 10" light units, with provisions for using a low cost, clear Mazda bulb, give the "direction" of the lights. The Hairlight and the Backlight are alike, the only difference being the use of the M428 Snoot with the Hairlight. By using 100 watt-sec. each on the mainlight and backlight, and 50 watt-sec. each on the fill light and hairlight, excellent lighting can be obtained for portrait work, including the use of Ektacolor Type S.

The A425 is the same as the A424 except that it has a fast recharge circuit.

THE 424 INCLUDES:

- 1 B424 Power Supply
- 2 L427 Light Units
- 2 F118 Modeling Lamps
- 1 M428 Snoot
- 2 L431 Light Units
- 2 F517 Flash Tubes
- 2 75-watt clear Mazda Bulbs
- 1 K107 Sync Cord

THE A425 INCLUDES:

- 1 B425 Power Supply
- 2 L431 Light Units
- 2 F517 Flash Tubes
- 2 75-watt clear Mazda Bulbs
- 1 K107 Sync Cord
- 2 L427 Light Units
- 2 F118 Modeling Lamps
- 1 M428 Snoot

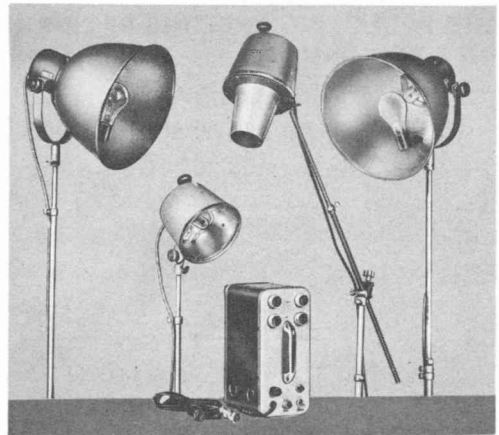

Figure 10

A424-A425

SPECIFICATIONS

LIGHT OUTPUT: 4000 BCPS/55° (100 w-s main light)

WATT-SEC: 300 (100-100-50-50)

GUIDE NO.: Ektacolor Type S 80; ASA 125 B&W 170

RECYCLE TIME: B424: 8 sec.; B425: 3 sec.

SPEED OF FLASH: 1/2500 sec.

VOLTAGE INPUT: 105-125 volts, 50-60 cycles AC

POWER INPUT: A425: 500 watts maximum with Modeling lights.

A425: 1000 watts maximum with Modeling Lights.

FUSE VALUE: A424: 1 6/10 amp Slo-Blo Type MDL

A425: 2 amp Slo-Blo Type MDL

SIZE: B424 & B425 Power Supplies - 10" x 4 1/2" x 6 1/2"

WEIGHT: B424 - 12 1/4 lbs. - B425 - 13 lbs.

B424 - B425 POWER SUPPLIES - SPECIAL INSTRUCTIONS

The light outlets of the B424 and B425 Power Supplies are divided into two banks; a 200 watt-sec. and a 100 watt-sec. bank. The two outlets at the front of the case are connected to the 200 watt-sec. bank, so that if only one light is used in either of these outlets, it will have 200 watt-sec.; if two lights are used, they will have 100 watt-sec. each.

The remaining two outlets are connected to the 100 watt-sec. bank. If one light is used in either of these outlets, it will have 100 watt-sec. If two lights are used in these outlets, they will have 50 watt-sec. each. It is important however, that at least one light is used in each bank at all times.

THE FOLLOWING LIGHTING RATIOS ARE THEREFORE OBTAINABLE WITH THIS UNIT.

- (a) 2 Lights: 200-100
- (b) 3 Lights: 200-50-50 or 100-100-100
- (c) 4 Lights: 100-100-50-50

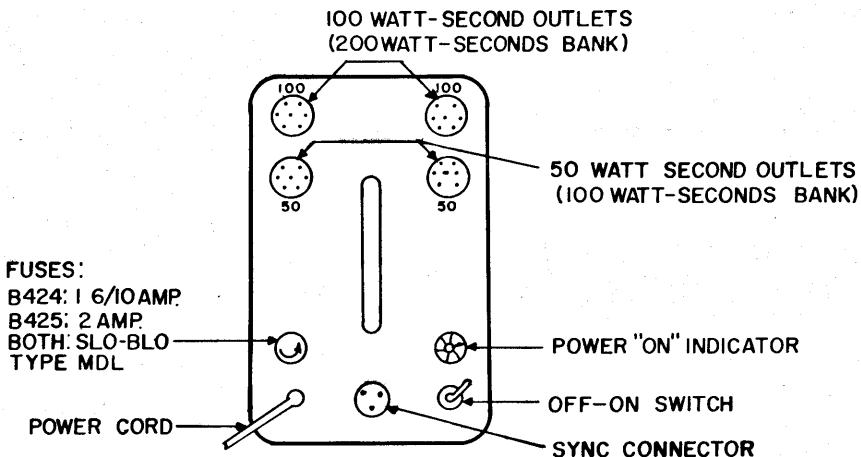

B424 & B425 POWER SUPPLIES

Figure 11

4.5 DESCRIPTION MODEL A426

A426 DELUXE SCHOOL COLOR ASSEMBLY

The A426 is a heavy duty, 300 w-s, four light assembly similar to the A425, except that it is a deluxe version featuring automatic light output stabilization. The photographer also has the capability of switching from left hand to right hand lighting just by throwing a switch.

The main light and fill light are the AL424B Type with permanently mounted 10" 55° reflectors. Each unit has three F108 60 watt modeling lamps which assures the photographer of getting "true modeling". The Hairlight and the Backlight are alike, the only difference being the use of the M428 snoot with the Hairlight. By using 100 w-s each on the main-light and backlight, and 50 w-s each on the fill light and hair light, excellent lighting results can be obtained for color portrait work.

The voltage stabilization circuit in the B426 Power Supply, when being used for production color portraiture, assures evenness from negative to negative throughout the whole roll of film.

The A426 comes equipped complete with stands, barndoors, diffusers, and a carrying case.

INCLUDES:

- 1 B426 Power Supply
- 2-AL427 Light Units
- 1 M428 Snoot
- 2 AL424B Light Units
- 1 K107 Sync Cord
- 2 M504 Barn Doors
- 2 M544 Diffusers
- 1 H425 Carrying Case
- 2 S201 Stands
- 1 S202 Stand
- 1 S203 Stand

SPECIFICATIONS

A426

LIGHT OUTPUT: 4,000 BCPS 55° (100 w-s main light)

WATT-SEC.: 300 (100-100-50-50)

GUIDE NO.: Ektacolor Type S 80; ASA 125 B&W 170

RECYCLE TIME: 3 sec.

SPEED OF FLASH: 1/2500 sec.

POWER INPUT: 1,000 watts maximum with Modeling lights.

VOLTAGE INPUT: 105-125 Volts, 50-60 cycles AC

FUSE VALUE: 4 amp Slo-Blo Type MDL

SIZE: 10" x 4½" x 6½"

WEIGHT: 14 lbs.

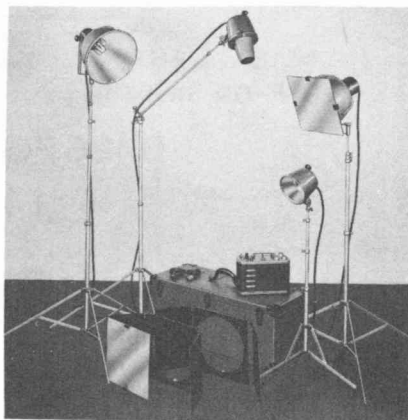
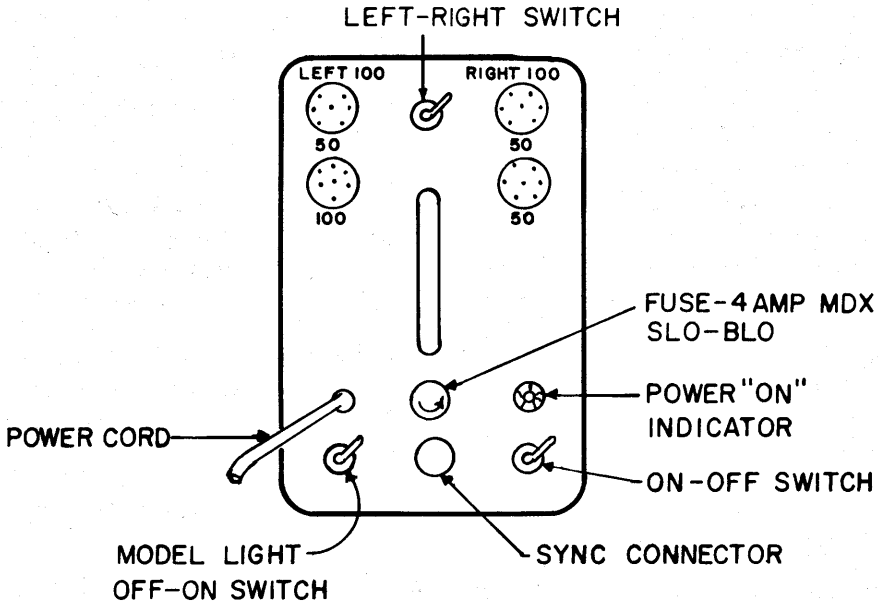

Figure 12

B426 POWER SUPPLY SPECIAL INSTRUCTIONS



B426 POWER SUPPLY

Figure 13

It is necessary that four lights be used on this power supply in order to operate properly. Light units attached to the bottom left and bottom right outlets will be flashed at 100 w-s and 50 w-s, respectively. The upper two outlets are connected so that one delivers 100 w-s and the other delivers 50 w-s. The selection of each is controlled by the position of the Left-Right switch. When the switch is in the Left position, the upper left outlet will deliver 100 w-s and the upper Right 50 w-s. When the switch is in the Right position, the upper Left will deliver 50 w-s and the upper Right 100 w-s.

4.6 DESCRIPTION MODEL A429

A429A & A429B ECONOMICAL STUDIO ASSEMBLIES

The A429A is an example of a combination of equipment that provides the most economical installation of four studio type lights with adequate power for color or black and white work. This Assembly includes stands and everything needed to do a job except for the camera.

Total 300 watt-sec.
(divided 100-100-50-50)

INCLUDES:

- 1 B424 Power Supply
- 2 AL429 Light Units
- 1 AL428 Baby Spot
- 1 AL427 Backlight
- 3 S514 Stands
- 1 S504 Boom Arm
- 1 S202 Stand
- 1 K107 Sync Cord.

Figure 14



A429B

The A429B is an Economy 600 watt-sec. 4-Light Studio Assembly divided (200-200-100-100) complete with studio type stands. It is the same as A429A but with the following items added:

- 1 B424 Power Supply
- 1 M102 Phototube Assembly.

SPECIFICATIONS: - A429A & A429B

LIGHT OUTPUT: A429A 2250 BCPS/60° (100 w-s main light)
A429B 4500 BCPS/60° (200 w.s main light)

WATT-SEC.: A429A - 300 (100-100-100)
A429B - 600 (200-200-100-100)

GUIDE NO.: A429A - Ektacolor Type S 56; ASA 125 B&W 130
A429B - Ektacolor Type S 85; ASA 125 B&W 180

RECYCLE TIME: A429A & A429B: 8 sec.

SPEED OF FLASH: A429A - 1/2500 sec.
A429B - 1/2000 sec.

VOLTAGE INPUT: 105-125 volts, 50-60 cycles AC

POWER INPUT: 500 watts maximum with Modeling lights.

FUSE VALUE: 1 6/10 amp Slo-Blo Type MDL

SIZE: B424 Power Supply: 10" x 4½" x 6½"

WEIGHT: B424: 12¼ lbs.

For additional instructions, please refer to Special Instructions on the B424 Power Supply.

4.7 DESCRIPTION MODEL B413

B413 POWER SUPPLY DESCRIPTION AND SPECIAL INSTRUCTIONS

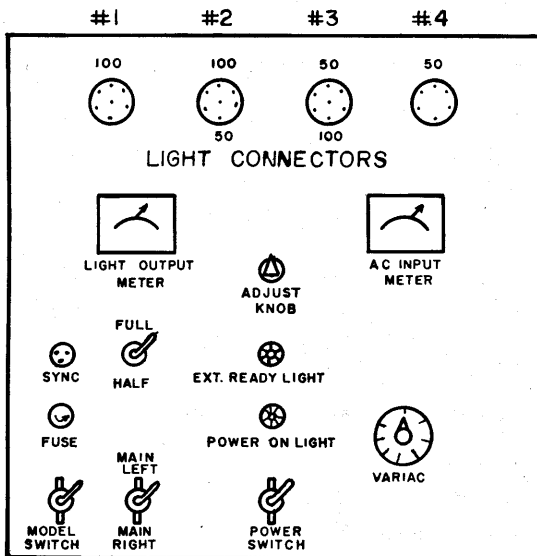

B413 POWER SUPPLY

Figure 15

The B413 power supply when operated with 4 light units will give 100 watt-seconds of power on each of two light units and 50 watt-seconds on each of the other two units. When operated with 3 light units, each light will obtain 100 watt-seconds of energy.

The placements and identification of the various controls is shown schematically in Fig. 15. A brief description of the function of each follows:

LIGHT CONNECTORS

The light units are connected to these connectors and will obtain the power shown. Note that to obtain 50 watt-seconds of power, a light unit must be connected to each 50 watt-second connector. With only one light unit connected to either 50 watt-seconds outlet, the light unit will receive 100 watt-seconds of energy.

MODELING SWITCH

This turns modeling lights ON and OFF. Modeling lights can be operated with power switch ON or OFF.

FUSE - 5 amp. Slo Blo

OPERATING INSTRUCTIONS – B413 POWER SUPPLY

1. Connect light units to the output connectors.
2. Plug AC plug into 105-125 volt, 50-60 cycle AC outlet
3. Turn power to ON.
4. Adjust AC input by means of varivolt variac, so that needle coincides with adjust mark.
5. Turn ADJUST knob so that ready light glows when the needle of the Light Output Meter has stopped or is moving very slowly. This will give a recycle time of approximately 3 to 5 seconds.
6. Connect sync cord to sync connector. Plug camera sync cord into female end of sync cord.
7. Turn modeling switch to ON.
8. Fire unit. When Ready Light glows, unit is ready to refire.

ADJUST KNOB

This, in conjunction with the Light Output Meter adjusts the point at which the Ready Light will glow.

LIGHT OUTPUT METER

This meter indicates to what extent the condensers have become charged. When condensers are fully charged, there will be no movement of the needle. At this point light output will be maximum.

AC INPUT METER

When the input voltage is adjusted to the indicated mark by means of the variac, the energy output will be as rated.

SYNC CONNECTOR

Sync Cord K107 is connected here. The female end of the sync cord is in turn connected to the camera sync cord.

EXTENSION READY LIGHT CONNECTOR

The Ready Light Extension is connected here. When unit is ready to flash, the Ready Light will glow.

POWER SWITCH

This toggle switch turns power for flashing light unit ON and OFF. Power indicator light will be lit when power is ON.

4.8 DESCRIPTION MODEL B415

B415 POWER SUPPLY DESCRIPTION AND SPECIAL OPERATING INSTRUCTIONS

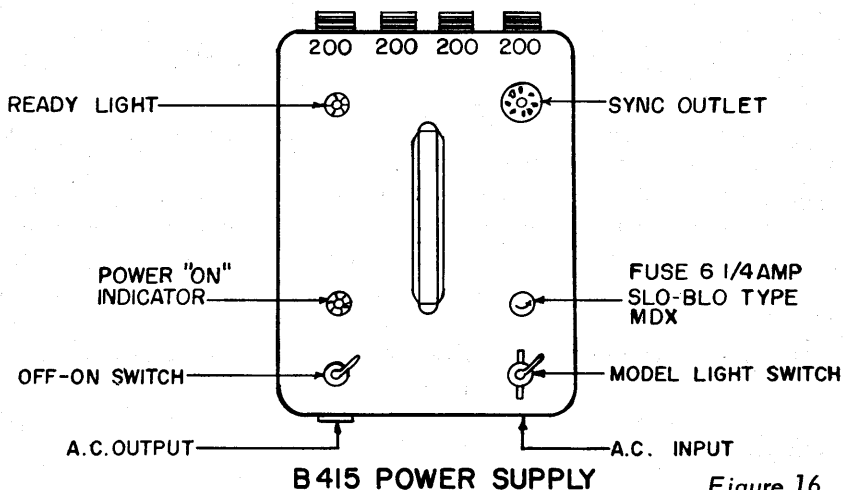

Figure 16

The B415 is an 800 watt-second, fast recharge, heavy duty power supply. It will operate any light unit in the 400 or 500 Series.

The power is divided into four banks of 200 watt-seconds each. This is to insure that 200 watt-second light units can be used without danger of overloading. The unit can be operated with any number of lights, from one to four. The sync outlet is the 8-pin type, enabling the use of the Lectro-Sync control as well as phototube synchronization.

OPERATING INSTRUCTIONS

1. Connect light units to proper connectors on power supply.
2. Connect either phototube, Lectro-Sync receiver, or sync cord, to sync outlet.
3. Insert power cord into A.C. Input connector and other end into 117 volt 50-60 cycle line of 1000 watts minimum capacity.
4. Turn on model light switch to operate model lights if desired.
5. Turn on power switch to operate unit.

SPECIFICATIONS

POWER INPUT	- 1000 watts maximum with modeling lamps
VOLTAGE INPUT	- 105-125 volts, 50-60 cycle AC
POWER OUTPUT	- 800 watt-seconds maximum.
RECHARGE TIME	- 8 seconds
FUSE VALUE	- 6¼ amp Slo-Blo Type MDX.
SIZE	- 12 x 7 x 9½
WEIGHT	- 19 pounds.

4.9 DESCRIPTION MODEL B416

B416 POWER SUPPLY DESCRIPTION AND SPECIAL INSTRUCTIONS

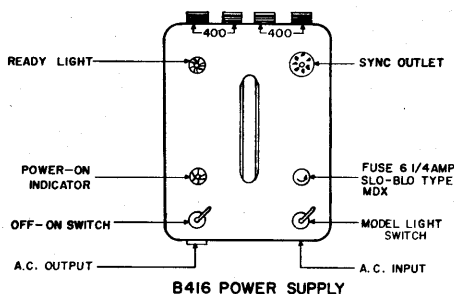

Figure 17

The B416 is an 800 watt-second, fast recharge, heavy duty power supply.

The power is divided into two banks of 400 watt-seconds each. This is to obtain various lighting ratios. For example, if two lights are used, one in each of the 400 banks, each light will give 400 watt-seconds. If, however, the two lights are put in to the two connectors on one 400 bank, each light will give 200 watt-seconds. Therefore, for a 400-200-200 ratio, one light is used in one outlet of a 400 bank, and two lights are used in the other bank.

The sync outlet is the 8-pin type, enabling the use of the Lectro-Sync remote control as well as phototube synchronization.

OPERATING INSTRUCTIONS

1. Connect light units to proper connectors on power supply.
2. Connect either phototube, Lectro-Sync receiver, or sync cord to sync outlet.
3. Insert power cord into A.C. Input connector and other end into 117 volt 50-60 cycle line of 1000 watts minimum capacity.
4. Turn on model light switch to operate model lights if desired.
5. Turn on power switch to operate unit.

SPECIFICATIONS

POWER INPUT	- 1000 watts maximum with modeling lamps
VOLTAGE INPUT	- 105-125 volts, 50-60 cycle A.C.
POWER OUTPUT	- 800 watt-seconds maximum
RECHARGE TIME	- 8 seconds
FUSE VALUE	- 6 1/4 amp Slo-Blo Type MDX
SIZE	- 12 x 7 x 9 1/2
WEIGHT	- 19 pounds

4.10 DESCRIPTION MODEL B421

OPERATING INSTRUCTIONS ASCORLIGHT B421 POWER SUPPLY

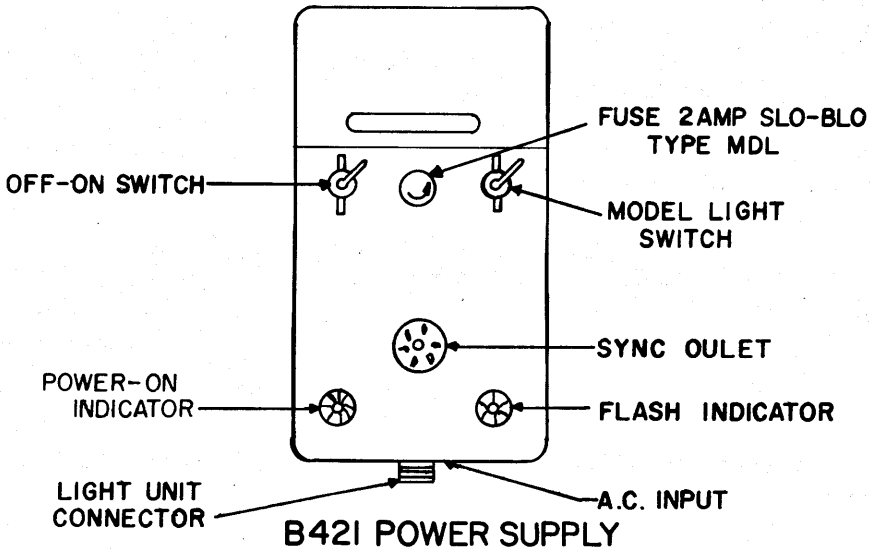

Figure 18

The B421 is a 400 watt-second, heavy duty power supply. It will operate any light unit in the 400 or 500 Series, rated for 400 watt-seconds. The sync outlet is the 8-pin type, enabling the use of the Lectro-sync remote control as well as phototube synchronization.

OPERATING INSTRUCTIONS

1. Connect light unit to connector on power supply.
2. Connect either phototube, Lectro-Sync receiver, or sync cord to sync outlet.
3. Insert power cord into A.C. Input connector and other end into 117 volt 50-60 cycle line of 500 watts minimum capacity.
4. Turn on model light switch to operate model lights if desired.
5. Turn on power switch to operate unit.

SPECIFICATIONS

POWER INPUT: 500 watts maximum with modeling lamps.

VOLTAGE INPUT: 105-125 volts, 50-60 cycle AC

POWER OUTPUT: 400 watt-seconds

RECHARGE TIME: 10 seconds

FUSE VALUE: 2 amp Slo-Blo Type MDL

SIZE: 10½" x 4¾" x 10"

WEIGHT: 20 pounds

5. OPERATING INSTRUCTIONS - Series 400

The operation of the Series 400 is very simple. The following sections will show you how to assemble the equipment, turn it ON, Synchronize with the camera, and turn it OFF. Basically, the operation of all of the units is the same.

5.1 ASSEMBLY - Series 400

The following steps will explain how to assemble the Series 400 units. The Flash Tube, Light Unit, and Power Supply should be assembled and connected together first with the switch in the OFF position and before connecting the AC cord.

- (1) Assemble Light Unit. Plug in Flash Tube and Reflector.
- (2) Connect power cable from the Light Unit to either connector on the Power Supply.
- (3) Mount the Light on Camera or Stand.
- (4) Either attach Sync Cord from the Camera to the Sync Connector on the Power Supply or insert the Phototube or Lectro-Sync Receiver.
- (5) Connect Power Cord from Power Supply to a wall outlet or other source of 117 volt, 50-60 cycle AC.

5.2 OPERATION

All that is involved in operating the unit is to turn the unit ON and when the condensers are charged up, flash the light either by tripping the camera shutter or by actuating the phototube with another pulse of light. Specific information on Synchronization with the camera is found in Sec. 6.2.

NOTE 1: - If the unit fails to operate properly see "Servicing", Sec. 8.

NOTE 2: - While it is possible to fire this unit in less time that it takes to recycle, it is not designed for this purpose and the results are less output of light with the possibility of blowing the fuse. THIS IS NORMAL, a safety feature which we have incorporated into the unit for your protection.

5.3 LECTRO-SYNC OPERATION

NOTE: The Lectro-Sync Remote Control System can be used only with power supplies equipped with proper circuitry for remote control. ASCOR B415, B416 and B421 Power Supplies are wired for this circuitry.

I. GENERAL

Lectro-Sync Remote Control System has been designed for triggering electronic flash units without the use of connecting sync cords or phototubes. The system consists of an M548 Lectro-Sync Transmitter which sends a CW signal over the power lines, and Lectro-Sync Control Receivers which are connected to the triggering circuit of the individual power supplies. A sync cord connects the Lectro-Sync Control Transmitter with the camera and each time the shutter is operated, the transmitter signal is interrupted, causing the Lectro-Sync Remote Control Receiver to generate a pulse which triggers the flash unit. As many receivers as desired can be operated with one transmitter.

II. INSTALLATION

Mount Lectro-Sync Transmitter on camera stand or near camera. Connect sync cord to the camera; sync cord should be 6 ft. max. length or shorter. Plug Transmitter into power line and turn the power on by depressing power-on push button switch. Power "ON" light should glow. Allow about 15 seconds for warm-up before operating transmitter.

Next plug in Lectro-Sync Receivers into the phototube sockets on the power supplies, making sure the power is OFF in the power supplies. Never plug in Receivers while the power is on, otherwise the Receiver might be damaged. Turn on all power supplies and after 30 seconds the system is ready to operate. Before making exposure turn the Transmitter off; the lights should flash, indicating that the system is working.

To ensure your exposure in full sync, shutter speed of 1/100 or slower is recommended.

III. OPERATING NOTES

(a) If you have difficulty, check first to see if the power supplies and lights themselves are operating. This can be done by using a regular sync cord connected to the camera shutter from each power supply or by using a push-button sync cord. A service man can do this by shorting pins No. 6 and No. 4 on the sync socket on the power supply.

(b) If you can flash the units by switching the Transmitter on and off or by shorting the sync outlet but the camera will not operate units, check your sync cord and your camera shutter.

(c) In case you can flash certain lights when they are plugged into certain power outlets but you cannot flash them in the other power outlets, you have the power supplies or the transmitter on the opposite sides of the A.C. line. This difficulty can be easily corrected by installing a coupling condenser .25 mfd. 600 volt directly across the 220 v. service in the main fuse box, (see diagram for connection). You can have an electrician make this installation, the .25 mfd. 600 volt capacitor can be obtained in any local radio store.

IV. OPERATING FREQUENCY

Lectro-Sync Remote Control System operates at 195 KC. In case two Transmitters on the same frequency are used on the same line, it will be impossible to flash the speedlights. In case this happens, it is suggested that the systems be tuned to different frequencies. This can easily be done by a competent radio repair man, as the frequency can be varied in a range of about 40 KC on both sides of the 195 KC to which it is originally tuned.

V. RANGE OF OPERATION

The actual range of operation depends on many factors, such as the number of fluorescent lights, appliances or machines operating on the line, type of load (capacitive load tends to shorten distance of operation), and whether the power lines are overhead or underground. Even under unfavorable conditions, the effective range of operation is 100 ft. Operation in the range of several hundred feet can be expected with lines that are less attenuated or where the conditions are favorable.

VI. RF INTERFERENCE

The system of using a continuous carrier current with the synchronization caused by the interruption of this carrier current provides built-in protection for interference to the operation of the Lectro-Sync System from devices operating in the vicinity.

The Lectro-Sync Transmitter does not cause interference by aerial radiation. Some radio receivers that do not have an input transformer can pick up interference because of the second and third harmonics on the power line transmission. This type of interference is easily tuned out by changing the setting on the tuning dial.

VII. TUNING OF LECTRO-SYNC SYSTEM

- (1) To tune the Lectro-Sync System to a different frequency, first use a frequency meter or a frequency B oscillator and adjust the capacitor C1 (Schematic SE354) to the correct frequency.
- (2) Attach a volt meter across resistor R1 in the receiver (Schematic SE365A) and adjust the slug of transformer T1 for minimum voltage reading.

6. PHOTOGRAPHIC AND TECHNICAL DATA

Most of the pertinent technical data is given in the Description of the model in Sec. 4. Additional details and discussion will be given in the following sub-sections.

6.1 TECHNICAL DATA

For Model A412 see Sec. 4.1

Model A414 see Sec. 4.2

Model A420 see Sec. 4.3

Model A424 see Sec. 4.4

Model A425 see Sec. 4.4

Model A426 see Sec. 4.5

Model A429 see Sec. 4.6

Model B413 see Sec. 4.7

Model B415 see Sec. 4.8

Model B416 see Sec. 4.9

Model B421 see Sec. 4.10

6.2 SYNCHRONIZATION

All ASCORLIGHT units use an electronic tube in the triggering circuit or sync circuit which directs the current through the flash tube – not the shutter contacts.

NOTE: Here we have incorporated ANOTHER SAFETY FEATURE to prevent electrical damage to the shutter contacts and to personnel. "The amount of current is only a tickle - not a shock".

The unit flashes when the two sync leads are "shorted" together. The flash occurs only a few microseconds (millionths) after this short (contact) is made. Since the time lag is negligible, this type of triggering is known as zero delay.

Most of the new type shutters are equipped with internal contacts for zero delay synchronization. For other type shutters synchronization may be accomplished by the simplest type of contact arrangement. Since the time lag between the closing of the circuit and the resulting flash is insignificant, accurate synchronization is obtained by adjusting the contacts so that the circuit is closed at the instant the shutter is fully open. However, contacts installed within the shutter body are superior and it is recommended that a qualified camera serviceman make the installation.

In the case of a Packard shutter, a microswitch or other type of contacts can be arranged so that the plunger actuates the contacts. For Compur, Supermatic, or similar shutters, the cocking lever can be used to actuate the spring contacts at the proper instant. In case the cocking lever itself is used as one contact, the ground lead in the SYNC cable should be connected to it. If a metal lens board is used, the spring contacts must be insulated from it.

Synchronization may be easily checked by aiming both the camera and the light at a light surface. Then, with the camera back open and the ground glass removed, look through the lens and trip the camera shutter and synchronizer. The high speed of the light makes it possible to observe the exact position of the shutter leaves at the instant of the flash. Adjustment should be made so that the shutter is completely open at the time of the Flash. You should see a perfect circle if your shutter is in sync. This check should be made with your fastest shutter speed.

6.3 LIGHT DATA

As previously mentioned the light output of ASCORLIGHT equipment is of daylight quality. This means that when referring to ASA ratings and exposure indexes of films the daylight ratings are used. Most film manufacturers specify the proper filters for color correction for their color films. Use filters as recommended for speedlight equipment. For a measure of the quantity of light we have found that the Beam candle power seconds (BCPS) is the most accurate measure of the amount of available light. This combined with reflector coverage is a much more realistic figure than watt-second rating which takes into account only the power supply. The B.C.P.S. values for combination of light unit and power supply is given below.

6.3.1 BCPS VALUES FOR COMBINATION OF LIGHT UNITS & POWER SUPPLIES

200 W-S ON MAIN LIGHT		BCPS/ANGLE OF COVERAGE
LIGHT UNIT		
L424 -		8000/55°
L429 -		4500/60°
L427 -		1650/90°
L428 -		4500/60°
		6000/25°
L431 -		8000/60°
100 W-S ON MAIN LIGHT		BCPS/ANGLE OF COVERAGE
LIGHT UNIT		
L424 -		4000/55°
L429 -		2250/60°
L427 -		825/90°
L428 -		2250/60°
		3000/25°
L431 -		4000/55°

6.4 EXPOSURE AND GUIDE NUMBERS

Guide numbers have long been used by photographers as an aid in estimating the proper F stop for flash bulbs. It is the product of the light-to-subject distance times the f stop. By dividing the distance of the light-to-subject into the guide number, the f stop is obtained. For example, with a guide number of 110 and a light-to-subject distance of 10 feet, the f stop would be f/11.

Due to tolerance in films and variations in technique, guide numbers can at best only be what the name suggests, a guide or starting point. Should more critical data be required, experimental tests by the photographer himself should be made.

6.5 ASCOR GUIDE NUMBER NOMOGRAPH FOR ELECTRONIC FLASH

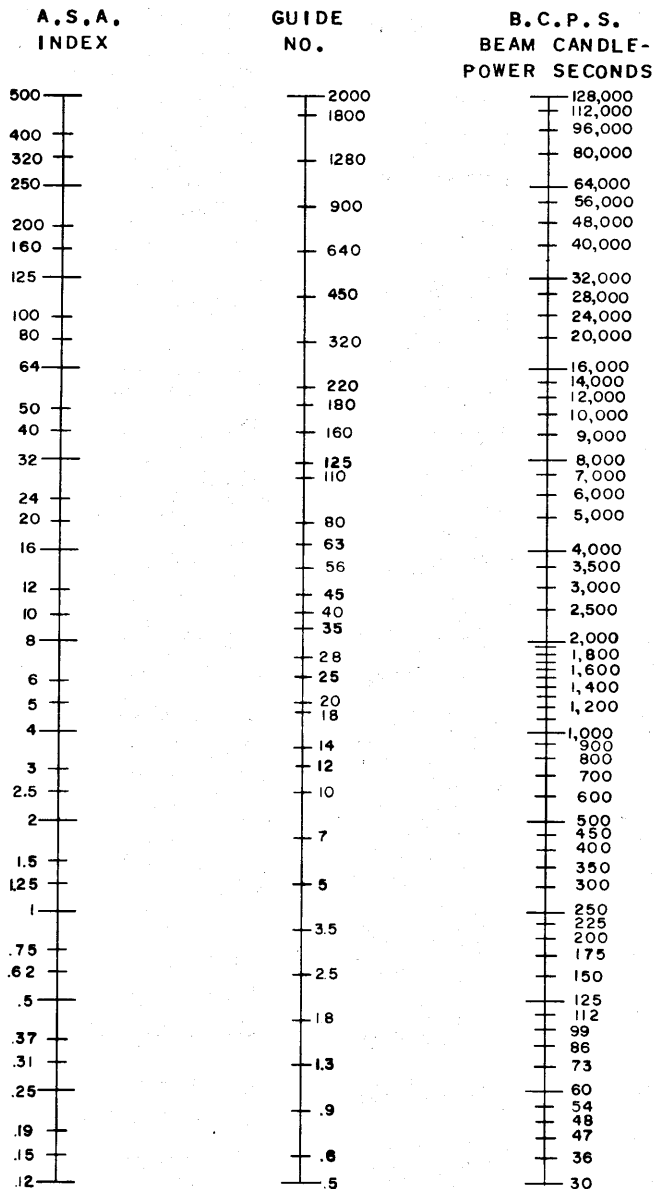

Figure 19

11-1-60 Issue 3

DIRECTIONS FOR USE OF GUIDE NUMBER NOMOGRAPH SHOWN BELOW

Know the ASA film speed number of the film you are using and the effective light output of your speedlight (B.C.P.S.). Lay a ruler or any straight edge on these two points and read the guide number at the point that the ruler crosses the center line. As an example; if you use a new color film with an EI of 32 and a unit with 7,500 Beam Candle Power seconds, the ruler would cross the center line at 125. A guide number of 125 would be proper for this situation.

6.6 DEVELOPMENT

Speedlight is just light. All the laws that apply to light, still apply to speedlight or electronic flash.

As in photography with incandescent lighting, the final image on the film is affected not only by the amount of light on the subject, but also by many other variables such as aperture, film speed, development techniques, etc. With speedlight shutter speed is not a factor since the flash is so fast that the film sees all of the flash even at the fastest shutter speeds.

It is possible to use special development techniques and developer and get an extremely high effective guide number. For many types of photography, this technique is quite satisfactory. To achieve optimum results for news photography, the Associated Press recommends with speedlights, about one-third longer than normal development time used with flash bulb exposures.

When the photographer desires to use a higher effective guide number (i.e. less exposure), normal contrast can be obtained by over-development. This is being commonly recommended for speedlight negatives. However, **NORMAL NEGATIVES** can be obtained with **NORMAL DEVELOPMENT** provided the negative is given **ADEQUATE EXPOSURE**. **ASCOR** guide numbers are for **NORMAL EXPOSURE AND NORMAL DEVELOPMENT**.

7. CARE AND MAINTENANCE

Although the ASCORLIGHT 400 Series Speedlights are ruggedly built pieces of electronic equipment, they should be handled with the same care given to any piece of quality equipment. To be assured of maximum dependable service, the photographer should observe the following precautions:

1. Avoid bending the cable sharply. Too sharp of a bend can break the wire in the cable.
2. If cable becomes frayed or connectors damaged, have them repaired immediately.
3. Keep all connectors free of dust, moisture and corrosion.
4. Do not connect or disconnect light units when capacitors are charged. (Turn control switch to "off" position and flash unit before disconnecting).
5. Avoid quick repeated flashing. Damage may result. The full charging time should be allowed between flashes.
6. Don't - Insert or remove a flash tube unless the power supply unit is fully discharged.

7. Don't - Insert a screwdriver or other metal object into the flash tube socket or any electric outlet, socket or receptacle. Contact with high voltage may result.
8. Don't - Place a hand or objects near any part inside the unit until you are certain that the capacitor bank is fully discharged.
9. Don't - Attempt to make repairs to ASCORLIGHT units if you are not familiar with electronic equipment. Your dealer should be consulted regarding our Authorization Service Station in your area.
10. Never use a higher rated fuse than is recommended.
11. Remember all ASCOR equipment is carefully designed to be SAFE when used in accordance with the instructions.
12. When not actually using your ASCORLIGHT unit, it is advisable to turn the unit "off".

8. SERVICE CHECKING PROCEDURES

8.1 IF UNIT DOES NOT OPERATE ON AC

Check to see that the power is properly connected and that the switch is in the proper position.

Check fuse; replace if necessary. See FUSE DATA SEC. 8.2.

Observe whether or not the indicator lamp on the power unit is glowing. If it is not glowing when the unit is turned on to AC position, no power is reaching the unit.

If the indicator lamp shows that power is reaching but the unit does not flash, observe whether or not the ready-light indicator on the power supply is blinking. If the ready-light indicator is blinking and the unit does not flash, the trouble is in the triggering circuit.

By taking a bent piece of wire, such as a paper clip, and inserting it into the sync connector on the power supply, one can flash the unit. If the unit flashes in this manner, but does not flash with the camera, the sync cord or the contacts in the shutter are defective.

Sometimes a camera is so constructed that one of the contacts is electrically connected to the frame of the camera. One side of the sync connector is grounded and the other side is "hot". If the sync connector is so inserted that the hot lead is connected to the grounded contact in the camera, the sync voltage is shorted out and the unit will not flash. All that is necessary to correct this is to reverse the plug 180 degrees.

If the above checks do not reveal the cause of trouble, a radio serviceman or preferably our Authorized Serviceman should be requested to check to see whether or not the capacitors are shorted.

8.2 FUSES

B412 - 2 Amp Slo-Blo MF	B420 - 1 Amp Slo-Blo MDL
B413 - 5 Amp Slo-Blo M!	B421 - 2 Amp Slo-Blo MDL
B414 - 1 Amp Slo-Blo MDL	B424 - 1 6/10 Amp Slo-Blo MDL
B415 - 6¼ Amp Slo-Blo MDX	B425 - 2 Amp Slo-Blo MDL
B416 - 6¼ Amp Slo-Blo MDX	B426 - 4 Amp Slo-Blo MDL

8.3 FLASH TUBES USED WITH SERIES 400

Most flash tubes used with the Series 400 are designed for 900 volt operation with a maximum of 200 watt-sec. per flash. The F517 and the circular Flash Tubes in the L427 and L432 are rated at 400 watt-seconds. WHEN USING 400 WATT-SECONDS POWER ON ANY ONE LIGHT MAKE CERTAIN THAT YOU ARE USING A FLASH TUBE RATED FOR 400 WATT-SECONDS. All plug in tubes are interchangeable as far as operation and flashing is concerned. Special features indicate the reason for their use.

Ascort No.	Supplier No.	Max. Power	Type of Base	Special Features	Recommended Use
F400	GE-FT217	200 w-s	4-pin	Glass Env.	Not to be used close to modeling lamps.
F402		200 w-s	4-pin	Opal Env.	For use in condenser enlarger.
F514	GE-FT221	200 w-s	4-pin	Pyrex Env.	To be used when close to modeling lamps.
F517		400 w-s	4-pin	Pyrex Env. Heavy Duty	Repetitive flashing or heavy duty applications.

9. AUXILIARY EQUIPMENT, ACCESSORIES & PARTS

There are accessories and parts that greatly increase the versatility and usefulness of your Series 400 Ascortlight. See the latest Series 400 and Series 500 Data Sheets for complete information. Note that any items in these two series can be used with your Series 400 Unit.

Manufactured by:

AMERICAN SPEEDLIGHT CORPORATION

63-01 Metropolitan Avenue, Middle Village 79, N. Y., U.S.A.